



**Board of County Commissioners**

**Eva J. Henry - District #1**  
**Charles "Chaz" Tedesco - District #2**  
**Emma Pinter - District #3**  
**Steve O'Dorisio - District #4**  
**Lynn Baca - District #5**

**PUBLIC HEARING AGENDA**

NOTICE TO READERS: The Board of County Commissioners' meeting packets are prepared several days prior to the meeting. This information is reviewed and studied by the Board members to gain a basic understanding, thus eliminating lengthy discussions. Timely action and short discussion on agenda items does not reflect a lack of thought or analysis on the Board's part. An informational packet is available for public inspection in the Board's Office one day prior to the meeting.

**THIS AGENDA IS SUBJECT TO CHANGE**

**Tuesday**  
**February 23, 2021**  
**9:30 AM**

**Watch the virtual meeting through our You Tube Channel**  
**<https://www.youtube.com/channel/UC7KDbF1XykrYlxnfhEH5XVA>**

**1. ROLL CALL**

**2. PLEDGE OF ALLEGIANCE**

**3. MOTION TO APPROVE AGENDA**

**4. AWARDS AND PRESENTATIONS**

- A.** National Association of Secretaries of State Award for Contributions to the 2020 Elections in Colorado

**5. PUBLIC COMMENT**

**A. Citizen Communication**

**Members of the public may submit written comments on any matter within the Board's subject matter jurisdiction or request to speak at the meeting through our eComment system at <https://adcogov.legistar.com/Calendar.aspx>**

**Residents are encouraged to submit comments, prior to the meeting, through written comment using eComment; eComment is integrated with the published meeting agenda and individuals may review the agenda item details and indicate their position on each item. A request to speak at the meeting may also be submitted using the eComment feature. You will be prompted to set up a user profile to allow you to comment, which will become part of the official public record. The eComment period opens when the agenda is published and closes at 4:30 p.m. the Monday prior to the noticed meeting.**

**B. Elected Officials' Communication**

## 6. CONSENT CALENDAR

- A. List of Expenditures Under the Dates of February 1-5, 2021
- B. Minutes of the Commissioners' Proceedings from February 9, 2021
- C. Resolution Approving Intergovernmental Agreement between the City of Commerce City and the Adams County Sheriff's Office for the Provision of Law Enforcement and Administrative Personnel  
(File approved by ELT)
- D. Resolution Approving Right-of-Way Agreement between Adams County and Isaac Mares and the David J. Mares and Rose M. Mares Trust Dated December 18, 2017 for Property Necessary for the Dahlia Street Roadway and Drainage Improvements Project from East 74th Avenue to East 78th Avenue  
(File approved by ELT)
- E. Resolution Approving Amendment 2 to Facility Usage Agreement between Adams County and Hyland Hills Park and Recreation District for a Public COVID-19 Testing Site  
(File approved by ELT)
- F. Resolution Approving Continuance of Intergovernmental Agreement between Adams County and the Municipal Partners for the A-Lift Transit Program  
(File approved by ELT)
- G. Resolution Approving Right-of-Way Agreement between Adams County and Hillen Holdings, LLC for Property Necessary for the Dahlia Street Roadway and Drainage Improvements Project East 74th Avenue to East 78th Avenue  
(File approved by ELT)
- H. Resolution Approving Community Services Block Grant Subgrantee Agreement between Adams County and Access Housing  
(File approved by ELT)
- I. Resolution Approving Community Services Block Grant Subgrantee Agreement between Adams County and Growing Home  
(File approved by ELT)
- J. Resolution Approving Community Services Block Grant Subgrantee Agreement between Adams County and Project Angel Heart  
(File approved by ELT)
- K. Resolution Approving Contract Cost Amendment between Adams County and Genesis Health Care, LLC for Long Term Care and Adult Medicaid Application Processing Services  
(File approved by ELT)
- L. Resolution Accepting Warranty Deed Conveying Property from Ogden North Enterprises, LLC, to Adams County for the Dedication of Road Right-of-Way  
(File approved by ELT)
- M. Resolution Approving Abatement Petitions and Authorizing the Refund of Taxes for Account Numbers P0038270, R0197628, R0083906, R0179912, R0182140 and R0810881  
(File approved by ELT)
- N. Resolution Regarding Defense and Indemnification of Jonathan Eller as a Defendant Pursuant to C.R.S. § 24-10-101, Et Seq., 20cv31391  
(File approved by ELT)

## **7. NEW BUSINESS**

### **A. COUNTY MANAGER**

1. Resolution Approving Amendment Two to the Agreement between Adams County and CliftonLarsonAllen, LLP for External Audit Services (File approved by ELT)
2. Resolution Approving Amendment Three to the Agreement between Adams County and Cesco Linguistic Services, Inc., to Provide Translation Services for Adams County (File approved by ELT)
3. Resolution Approving Amendment Three to the Agreement between Adams County and A&A Languages, LLC, for Translation Services (File approved by ELT)
4. Resolution Approving an Agreement between Adams County and Myers & Sons Construction, LLC, to Provide Construction Services for the 96th Avenue Bridge Over Bijou Creek Phase Two Project (File approved by ELT)

### **B. COUNTY ATTORNEY**

## **8. LAND USE HEARINGS**

### **A. Cases to be Heard**

1. RCU2020-00026 Burke Rezoning (File approved by ELT)
2. RCU2020-00038 StreetMedia 6612 York Street Billboard CUP (File approved by ELT)
3. RCU2020-00014 StreetMedia 7154 Washington Billboard CUP (File approved by ELT)

## **9. ADJOURNMENT**

**AND SUCH OTHER MATTERS OF PUBLIC BUSINESS WHICH MAY ARISE**

**County of Adams**  
**Net Warrant by Fund Summary**

<b>Fund Number</b>	<b>Fund Description</b>	<b>Amount</b>
1	General Fund	1,607,072.42
4	Capital Facilities Fund	4,912.50
5	Golf Course Enterprise Fund	76,481.37
6	Equipment Service Fund	109,051.46
13	Road & Bridge Fund	224,066.89
19	Insurance Fund	610,263.14
27	Open Space Projects Fund	3,307.50
28	Open Space Sales Tax Fund	410,026.84
30	Community Dev Block Grant Fund	9,382.25
31	Head Start Fund	5,115.57
35	Workforce & Business Center	19,448.90
43	Colorado Air & Space Port	41,164.53
		<u>3,120,293.37</u>

## Net Warrants by Fund Detail

1      General Fund

<u>Warrant</u>	<u>Supplier No</u>	<u>Supplier Name</u>	<u>Warrant Date</u>	<u>Amount</u>
00007131	545155	JP MORGAN CHASE BANK NA	2/3/2021	644,322.06
00007132	320525	ARIAS REBECCA M	2/3/2021	4,179.00
00007133	378404	CARUSO JAMES LOUIS	2/3/2021	5,375.00
00007134	37193	CINA & CINA FORENSIC CONSULTIN	2/3/2021	13,200.00
00007135	952870	FENICE PARTNERS LLC	2/3/2021	21,005.80
00007136	1016895	G4S SECURE SOLUTIONS USA INC	2/3/2021	6,473.20
00007138	1053561	SIEGEL THOMAS WEIL	2/3/2021	250.00
00007141	1053458	BRYAN LAURA CHRISTINE	2/5/2021	375.00
00007144	1016895	G4S SECURE SOLUTIONS USA INC	2/5/2021	21,607.08
00756450	48724	ACCELA INC	2/4/2021	14,827.21
00756451	35974	ADAMS COUNTY TREASURER	2/4/2021	1,807.91
00756452	1063594	ADT COMMERCIAL LLC	2/4/2021	841.58
00756457	786384	ALTITUDE COMMUNITY LAW	2/4/2021	19.00
00756458	518015	ANM	2/4/2021	109,150.00
00756459	1074737	ARA INC	2/4/2021	1,894.40
00756462	43744	AUTOMATED BUILDING SOLUTIONS I	2/4/2021	8,875.00
00756467	1128474	BUSTAMANTE TONY	2/4/2021	1,400.00
00756468	726898	CA SHORT COMPANY	2/4/2021	35,974.59
00756469	1128821	CARRILLO ORTIZ JONATHAN	2/4/2021	32.00
00756478	250958	COHEN MILSTEIN SELLERS & TOLL	2/4/2021	472.50
00756479	8024	COLO COUNTY ATTORNEYS ASSN	2/4/2021	600.00
00756480	5407	COLO DEPT OF LABOR & EMPLOYME	2/4/2021	60.00
00756481	5602	COLO DEPT OF LABOR & EMPLOYMEN	2/4/2021	120.00
00756482	300351	COLO MOUNTED LAW ENFORCEMENT A	2/4/2021	50.00
00756484	1107384	COLUMBINE FEDERAL CREDIT UNION	2/4/2021	210.72
00756486	621872	CORAK NEVEN	2/4/2021	66.00
00756488	152261	DATASPEC LLC	2/4/2021	449.00
00756492	22418	DLT SOLUTIONS LLC	2/4/2021	280.84
00756493	207312	DOUGLASS COLONY GROUP INC	2/4/2021	407,613.65
00756494	808844	DUPRIEST JOHN FIELDEN	2/4/2021	65.00
00756496	219503	ELKUS & SISSON PC AND	2/4/2021	3,424.33
00756497	810281	ELLIOTT LEGAL INVESTIGATIONS	2/4/2021	19.00
00756499	13454	FEDERAL EXPRESS CO	2/4/2021	35.50
00756500	47723	FEDEX	2/4/2021	40.85
00756501	1042593	FLEX FLEET RENTAL LLC	2/4/2021	5,040.00
00756502	698569	FOREST SEAN	2/4/2021	65.00

## Net Warrants by Fund Detail

1      General Fund

<u>Warrant</u>	<u>Supplier No</u>	<u>Supplier Name</u>	<u>Warrant Date</u>	<u>Amount</u>
00756503	426777	FRANCY LAW FIRM	2/4/2021	57.00
00756504	506511	FRANK J BALL	2/4/2021	19.00
00756505	12689	GALLS LLC	2/4/2021	10,969.96
00756506	1128816	GARCIA EMMA CHRISTINE	2/4/2021	49.00
00756507	293118	GARNER, ROSIE	2/4/2021	65.00
00756509	1004844	GPS SERVERS LLC	2/4/2021	43.00
00756510	1116206	GREAT ECOLOGY & ENVIRONMENTS I	2/4/2021	1,286.25
00756513	293122	HERRERA, AARON	2/4/2021	65.00
00756514	10864	HILLYARD - DENVER	2/4/2021	172.84
00756515	358482	HOLST AND BOETTCHER	2/4/2021	19.00
00756516	1064721	HRQ INC	2/4/2021	78.85
00756517	59100	HYDRO RESOURCES	2/4/2021	1,507.76
00756519	32276	INSIGHT PUBLIC SECTOR	2/4/2021	45,287.92
00756520	859588	JAZOWSKI KAREN	2/4/2021	3,550.00
00756521	77611	KD SERVICE GROUP	2/4/2021	25,754.77
00756523	938469	LAPLINK SOFTWARE INC	2/4/2021	7,650.00
00756524	374466	LAW OFFICES OF BRANDON CEGLIAN	2/4/2021	38.00
00756525	1129280	LIQUID ENVIRO SOLUTIONS OF TEX	2/4/2021	1,063.72
00756527	975291	MADDUX THOMAS SCOTT	2/4/2021	65.00
00756528	488944	MAIL MASTERS OF COLORADO	2/4/2021	1,800.00
00756529	810888	MARTINEZ JUSTIN PAUL	2/4/2021	65.00
00756532	32947	MOBILE STORAGE SOLUTIONS	2/4/2021	8,106.67
00756535	971360	NAVAL SURFACE WARFARE CENTER C	2/4/2021	7,500.00
00756536	570347	NELSON AND KENNARD	2/4/2021	19.00
00756537	1128823	NGUYEN NANCY	2/4/2021	19.00
00756538	1004574	OCHS CRYSTAL	2/4/2021	870.00
00756539	770072	OLIVER JO MARIE	2/4/2021	66.00
00756540	470643	ONENECK IT SOLUTIONS LLC	2/4/2021	10,464.18
00756541	1128817	PAPPAS JIM GEORGE	2/4/2021	66.00
00756542	516994	PARK 12 HUNDRED OWNERS ASSOCIA	2/4/2021	48,861.76
00756543	923551	PATTON AND DAVIDSON	2/4/2021	173.00
00756544	720230	PHILLIPS PET FOOD & SUPPLIES	2/4/2021	649.45
00756548	44148	PRO FORCE LAW ENFORCEMENT	2/4/2021	4,192.00
00756549	837076	PSYCHOLOGICAL DIMENSIONS	2/4/2021	6,450.00
00756550	8348	PUEBLO COUNTY GOVERNMENT	2/4/2021	930.00
00756552	53054	RICHARDSON SHARON	2/4/2021	65.00

## Net Warrants by Fund Detail

1      **General Fund**

<u>Warrant</u>	<u>Supplier No</u>	<u>Supplier Name</u>	<u>Warrant Date</u>	<u>Amount</u>
00756553	422902	ROADRUNNER PHARMACY INCORPORAT	2/4/2021	773.72
00756554	1128476	RODRIGUEZ SONIA	2/4/2021	700.00
00756557	1031727	SGR	2/4/2021	5,140.18
00756559	316125	SMART COMMUTE METRO NORTH	2/4/2021	20,787.50
00756560	599714	SUMMIT FOOD SERVICE LLC	2/4/2021	31,544.12
00756561	41889	SUNSTATE EQUIPMENT CO LLC	2/4/2021	6,277.36
00756563	47341	T MOBILE	2/4/2021	30.56
00756564	618144	T&G PECOS LLC	2/4/2021	3,600.00
00756567	498722	THERMAL & MOISTURE PROTECTION	2/4/2021	2,665.00
00756568	1128822	THOMPSON BRODY AND KAPLAN	2/4/2021	56.00
00756569	385142	THOMPSON GREGORY PAUL	2/4/2021	65.00
00756570	1128775	TOMCZAK MICHAEL E	2/4/2021	50.00
00756572	1114229	TOSCANA MC JV LLC	2/4/2021	1,299.00
00756573	38221	TRANE US INC	2/4/2021	32,149.19
00756574	1128819	TRUJILLO ALEJANDRO R	2/4/2021	19.00
00756600	35731	VERIZON	2/4/2021	476.82
00756602	196791	WELLINGTON RESERVOIR COMPANY	2/4/2021	480.00
00756604	8498	WRIGHT WATER ENGINEERS	2/4/2021	2,660.62
00756637	1128820	ZHANG XIONG WEN	2/4/2021	19.00
00756638	1128818	ZHOU QUANYI	2/4/2021	19.00
<b>Fund Total</b>				<b>1,607,072.42</b>

**County of Adams**  
**Net Warrants by Fund Detail**

4 **Capital Facilities Fund**

<u>Warrant</u>	<u>Supplier No</u>	<u>Supplier Name</u>	<u>Warrant Date</u>	<u>Amount</u>
00756551	1031627	REDLAND	2/4/2021	4,912.50
<b>Fund Total</b>				<b>4,912.50</b>



## Net Warrants by Fund Detail

5 Golf Course Enterprise Fund

<u>Warrant</u>	<u>Supplier No</u>	<u>Supplier Name</u>	<u>Warrant Date</u>	<u>Amount</u>
00007137	6177	PROFESSIONAL RECREATION MGMT I	2/3/2021	9,000.00
00007147	6177	PROFESSIONAL RECREATION MGMT I	2/5/2021	4,261.82
00756454	8579	AGFINITY INC	2/4/2021	839.48
00756455	12012	ALSCO AMERICAN INDUSTRIAL	2/4/2021	168.39
00756466	9822	BUCKEYE WELDING SUPPLY CO INC	2/4/2021	30.60
00756483	64104	COLO POWDER COATING	2/4/2021	630.00
00756533	150692	MODERN GOLF & TURF LLC	2/4/2021	60,835.00
00756545	152295	POTESTIO BROTHER EQUIPMENT	2/4/2021	483.08
00756571	47140	TORO NSN	2/4/2021	233.00
<b>Fund Total</b>				<b>76,481.37</b>

## Net Warrants by Fund Detail

6Equipment Service Fund

<u>Warrant</u>	<u>Supplier No</u>	<u>Supplier Name</u>	<u>Warrant Date</u>	<u>Amount</u>
00756464	32682	BEARCOM WIRELESS WORLDWIDE	2/4/2021	17,307.03
00756487	40977	DANIELS LONG CHEVROLET	2/4/2021	19,470.00
00756518	682207	INSIGHT AUTO GLASS LLC	2/4/2021	432.86
00756546	324769	PRECISE MRM LLC	2/4/2021	5,592.00
00756556	16237	SAM HILL OIL INC	2/4/2021	33,125.51
00756558	28084	SILL TERHAR MOTORS INC	2/4/2021	26,063.00
00756565	790907	THE GOODYEAR TIRE AND RUBBER C	2/4/2021	5,912.15
00756603	350373	WEX BANK	2/4/2021	1,148.91
<b>Fund Total</b>				<b>109,051.46</b>

## Net Warrants by Fund Detail

13

## Road &amp; Bridge Fund

<u>Warrant</u>	<u>Supplier No</u>	<u>Supplier Name</u>	<u>Warrant Date</u>	<u>Amount</u>
00007153	171233	LAND TITLE GUARANTEE COMPANY	2/5/2021	3,038.00
00007154	171233	LAND TITLE GUARANTEE COMPANY	2/5/2021	75,564.00
00007155	171233	LAND TITLE GUARANTEE COMPANY	2/5/2021	67,066.00
00756456	12012	ALSCO AMERICAN INDUSTRIAL	2/4/2021	279.57
00756475	43659	CINTAS FIRST AID & SAFETY	2/4/2021	170.07
00756476	648873	CITY OF THORNTON UTILITIES	2/4/2021	4,045.51
00756477	2305	COBITCO INC	2/4/2021	108.90
00756490	237568	DESIGN WORKSHOP	2/4/2021	18,794.46
00756511	727893	HCL ENGINEERING & SURVEYING LL	2/4/2021	14,620.00
00756512	92426	HDR ENGINEERING INC	2/4/2021	3,500.00
00756530	21134	METECH RECYCLING	2/4/2021	835.38
00756534	1117025	NATIONAL SOCIETY OF PROF ENGIN	2/4/2021	2,332.00
00756547	556555	PREMIER PORTABLES	2/4/2021	350.00
00756566	790907	THE GOODYEAR TIRE AND RUBBER C	2/4/2021	1,341.00
00756576	1007	UNITED POWER (UNION REA)	2/4/2021	23.16
00756577	1007	UNITED POWER (UNION REA)	2/4/2021	48.28
00756578	1007	UNITED POWER (UNION REA)	2/4/2021	16.50
00756579	1007	UNITED POWER (UNION REA)	2/4/2021	16.50
00756580	1007	UNITED POWER (UNION REA)	2/4/2021	16.50
00756581	1007	UNITED POWER (UNION REA)	2/4/2021	53.33
00756582	1007	UNITED POWER (UNION REA)	2/4/2021	62.71
00756583	1007	UNITED POWER (UNION REA)	2/4/2021	151.34
00756584	1007	UNITED POWER (UNION REA)	2/4/2021	147.87
00756585	1007	UNITED POWER (UNION REA)	2/4/2021	51.69
00756586	1007	UNITED POWER (UNION REA)	2/4/2021	34.00
00756587	1007	UNITED POWER (UNION REA)	2/4/2021	156.30
00756588	1007	UNITED POWER (UNION REA)	2/4/2021	166.16
00756589	1007	UNITED POWER (UNION REA)	2/4/2021	20.31
00756590	1007	UNITED POWER (UNION REA)	2/4/2021	52.87
00756591	1007	UNITED POWER (UNION REA)	2/4/2021	58.32
00756592	1007	UNITED POWER (UNION REA)	2/4/2021	69.42
00756593	1007	UNITED POWER (UNION REA)	2/4/2021	41.07
00756594	1007	UNITED POWER (UNION REA)	2/4/2021	66.00
00756595	1007	UNITED POWER (UNION REA)	2/4/2021	33.00
00756596	1007	UNITED POWER (UNION REA)	2/4/2021	36.00
00756597	1007	UNITED POWER (UNION REA)	2/4/2021	88.49

## Net Warrants by Fund Detail

13Road & Bridge Fund

<u>Warrant</u>	<u>Supplier No</u>	<u>Supplier Name</u>	<u>Warrant Date</u>	<u>Amount</u>
00756598	158184	UTILITY NOTIFICATION CENTER OF	2/4/2021	138.57
00756605	13822	XCEL ENERGY	2/4/2021	131.72
00756606	13822	XCEL ENERGY	2/4/2021	60.86
00756607	13822	XCEL ENERGY	2/4/2021	211.90
00756608	13822	XCEL ENERGY	2/4/2021	11.77
00756609	13822	XCEL ENERGY	2/4/2021	137.00
00756610	13822	XCEL ENERGY	2/4/2021	48.05
00756611	13822	XCEL ENERGY	2/4/2021	31.95
00756612	13822	XCEL ENERGY	2/4/2021	44.99
00756613	13822	XCEL ENERGY	2/4/2021	143.05
00756614	13822	XCEL ENERGY	2/4/2021	103.83
00756615	13822	XCEL ENERGY	2/4/2021	24,716.79
00756616	13822	XCEL ENERGY	2/4/2021	4,831.70
<b>Fund Total</b>				<b>224,066.89</b>

## Net Warrants by Fund Detail

**19 Insurance Fund**

<u>Warrant</u>	<u>Supplier No</u>	<u>Supplier Name</u>	<u>Warrant Date</u>	<u>Amount</u>
00007139	523053	TRISTAR RISK MANAGEMENT	2/3/2021	54,981.91
00007143	423439	DELTA DENTAL OF COLO	2/5/2021	126,519.88
00007149	1089885	THE TABEN GROUP	2/5/2021	900.00
00007151	37223	UNITED HEALTH CARE INSURANCE C	2/5/2021	192,064.84
00007152	37223	UNITED HEALTH CARE INSURANCE C	2/5/2021	74,163.59
00007158	523053	TRISTAR RISK MANAGEMENT	2/5/2021	87,500.00
00756453	331018	AED AUTHORITY	2/4/2021	195.00
00756460	13534	ARGO SUSAN L	2/4/2021	47,221.09
00756463	1076668	BAKKEN CHRISTEN	2/4/2021	480.00
00756498	13448	FARIS MACHINERY CO	2/4/2021	13,457.92
00756522	64854	KING & GREISEN LLP	2/4/2021	12,778.91
<b>Fund Total</b>				<b>610,263.14</b>

Net Warrants by Fund Detail

27

Open Space Projects Fund

<u>Warrant</u>	<u>Supplier No</u>	<u>Supplier Name</u>	<u>Warrant Date</u>	<u>Amount</u>
00756491	101347	DHM DESIGNS	2/4/2021	3,307.50
<b>Fund Total</b>				<b>3,307.50</b>

## Net Warrants by Fund Detail

28Open Space Sales Tax Fund

<u>Warrant</u>	<u>Supplier No</u>	<u>Supplier Name</u>	<u>Warrant Date</u>	<u>Amount</u>
00007140	39402	BIRD CONSERVANCY OF THE ROCKIE	2/5/2021	19,008.75
00007145	372951	HYLAND HILLS PARK AND RECREATI	2/5/2021	309,000.00
00007146	1116926	LUBIRDS LIGHT FOUNDATION	2/5/2021	68,038.29
00007150	43150	THORNTON CITY OF	2/5/2021	13,979.80
<b>Fund Total</b>				<b>410,026.84</b>

## Net Warrants by Fund Detail

30Community Dev Block Grant Fund

<u>Warrant</u>	<u>Supplier No</u>	<u>Supplier Name</u>	<u>Warrant Date</u>	<u>Amount</u>
00007156	1081553	MANKO SERIVCE INC	2/5/2021	2,383.25
00007157	1075724	PINNACLE PEDIATRICS AND INTERN	2/5/2021	6,999.00
			<b>Fund Total</b>	<b>9,382.25</b>



Net Warrants by Fund Detail

**31**      **Head Start Fund**

---

<u>Warrant</u>	<u>Supplier No</u>	<u>Supplier Name</u>	<u>Warrant Date</u>	<u>Amount</u>
00756470	37266	CENTURY LINK	2/4/2021	120.76
00756471	37266	CENTURY LINK	2/4/2021	485.86
00756472	152461	CENTURYLINK	2/4/2021	11.86
00756474	327914	CESCO LINGUISTIC SERVICE INC	2/4/2021	95.09
00756508	971545	GENESIS FLOOR CARE OF COLORADO	2/4/2021	2,322.00
00756531	1090294	MIGHTY LITTLE VOICES SPEECH TH	2/4/2021	2,080.00
<b>Fund Total</b>				<b>5,115.57</b>

Net Warrants by Fund Detail

35

**Workforce & Business Center**

<u>Warrant</u>	<u>Supplier No</u>	<u>Supplier Name</u>	<u>Warrant Date</u>	<u>Amount</u>
00007148	77305	ROSTIE SANDRA	2/5/2021	2,600.00
00756465	1118670	BOULDER MEDICAL CENTER PC	2/4/2021	5,000.00
00756473	152461	CENTURYLINK	2/4/2021	1.96
00756485	1483	COMPUTER SYSTEMS DESIGN	2/4/2021	4,800.00
00756599	84904	VCA ASPENWOOD ANIMAL HOSPITAL	2/4/2021	6,000.00
00756601	8076	VERIZON WIRELESS	2/4/2021	1,046.94
<b>Fund Total</b>				<b>19,448.90</b>

## Net Warrants by Fund Detail

43

## Colorado Air &amp; Space Port

<u>Warrant</u>	<u>Supplier No</u>	<u>Supplier Name</u>	<u>Warrant Date</u>	<u>Amount</u>
00007142	709816	CITY SERVICEVALCON LLC	2/5/2021	25,189.72
00756461	351622	AURORA WATER	2/4/2021	2,359.74
00756489	556579	DBT TRANSPORTATION SERVICES LL	2/4/2021	2,408.34
00756495	13410	EASTERN SLOPE RURAL TELEPHONE	2/4/2021	131.82
00756526	112383	LOTTMAN OIL COMPANY	2/4/2021	594.00
00756555	44131	ROGGEN FARMERS ELEVATOR ASSN	2/4/2021	2,138.24
00756562	80267	SWIMS DISPOSAL	2/4/2021	298.75
00756575	80271	TWS AVIATION FUEL SYSTEMS	2/4/2021	320.00
00756617	13822	XCEL ENERGY	2/4/2021	63.23
00756618	13822	XCEL ENERGY	2/4/2021	151.58
00756619	13822	XCEL ENERGY	2/4/2021	171.34
00756620	13822	XCEL ENERGY	2/4/2021	519.76
00756621	13822	XCEL ENERGY	2/4/2021	1,170.63
00756622	13822	XCEL ENERGY	2/4/2021	12.67
00756623	13822	XCEL ENERGY	2/4/2021	14.30
00756624	13822	XCEL ENERGY	2/4/2021	17.22
00756625	13822	XCEL ENERGY	2/4/2021	36.55
00756626	13822	XCEL ENERGY	2/4/2021	48.13
00756627	13822	XCEL ENERGY	2/4/2021	50.89
00756628	13822	XCEL ENERGY	2/4/2021	65.71
00756629	13822	XCEL ENERGY	2/4/2021	79.30
00756630	13822	XCEL ENERGY	2/4/2021	99.83
00756631	13822	XCEL ENERGY	2/4/2021	143.69
00756632	13822	XCEL ENERGY	2/4/2021	164.75
00756633	13822	XCEL ENERGY	2/4/2021	834.23
00756634	13822	XCEL ENERGY	2/4/2021	892.74
00756635	13822	XCEL ENERGY	2/4/2021	1,353.34
00756636	13822	XCEL ENERGY	2/4/2021	1,834.03

**Fund Total****41,164.53**

**County of Adams**  
**Net Warrants by Fund Detail**

**Grand Total**      3,120,293.37

**County of Adams**  
**Vendor Payment Report**

<u>9479</u>	<u>Administrative Cost Pool</u>	<u>Fund</u>	<u>Voucher</u>	<u>Batch No</u>	<u>GL Date</u>	<u>Amount</u>
	Legal Notices					
	PCard JE	00030	989953	383751	1/23/2021	51.48
					Account Total	51.48
	Operating Supplies					
	PCard JE	00030	989953	383751	1/23/2021	19.99
	PCard JE	00030	989953	383751	1/23/2021	40.01
					Account Total	60.00
					Department Total	111.48

**County of Adams**  
**Vendor Payment Report**

<u>3040X2601010</u>	<u>Adult Prot Admin</u>	<u>Fund</u>	<u>Voucher</u>	<u>Batch No</u>	<u>GL Date</u>	<u>Amount</u>
	Equipment Rental					
	PCard JE	00015	989953	383751	1/23/2021	149.23
	PCard JE	00015	989953	383751	1/23/2021	5.52
	PCard JE	00015	989953	383751	1/23/2021	5.18
					Account Total	<u>159.93</u>
	Other Professional Serv					
	PCard JE	00015	989953	383751	1/23/2021	96.96
					Account Total	<u>96.96</u>
	Printing External					
	PCard JE	00015	989953	383751	1/23/2021	20.00
					Account Total	<u>20.00</u>
					Department Total	<u><u>276.89</u></u>

**County of Adams**  
**Vendor Payment Report**

<u>3040P2601012</u>	<u>Adult Prot Client Benefits</u>	<u>Fund</u>	<u>Voucher</u>	<u>Batch No</u>	<u>GL Date</u>	<u>Amount</u>
	Operating Supplies					
	PCard JE	00015	989953	383751	1/23/2021	<u>304.38</u>
					Account Total	<u>304.38</u>
					Department Total	<u><u>304.38</u></u>

**County of Adams**  
**Vendor Payment Report**

<u>3040P9999900</u>	<u>Adult Prot Non-Reimbursable</u>	<u>Fund</u>	<u>Voucher</u>	<u>Batch No</u>	<u>GL Date</u>	<u>Amount</u>
	County Client/Provider					
	PCard JE	00015	989953	383751	1/23/2021	125.33
	PCard JE	00015	989953	383751	1/23/2021	13.99
					Account Total	139.32
					Department Total	139.32



**County of Adams**  
**Vendor Payment Report**

<u>99800</u>	<u>All Ofc Shared Direct</u>	<u>Fund</u>	<u>Voucher</u>	<u>Batch No</u>	<u>GL Date</u>	<u>Amount</u>
	Equipment Rental					
	PCard JE	00035	989953	383751	1/23/2021	281.64
	PCard JE	00035	989953	383751	1/23/2021	167.28
	PCard JE	00035	989953	383751	1/23/2021	167.28
	PCard JE	00035	989953	383751	1/23/2021	155.09
	PCard JE	00035	989953	383751	1/23/2021	156.74
	PCard JE	00035	989953	383751	1/23/2021	184.21
	PCard JE	00035	989953	383751	1/23/2021	124.62
	PCard JE	00035	989953	383751	1/23/2021	130.60
	PCard JE	00035	989953	383751	1/23/2021	149.23
	PCard JE	00035	989953	383751	1/23/2021	36.47
	PCard JE	00035	989953	383751	1/23/2021	133.63
	PCard JE	00035	989953	383751	1/23/2021	.03
	PCard JE	00035	989953	383751	1/23/2021	93.04
	PCard JE	00035	989953	383751	1/23/2021	42.36
	PCard JE	00035	989953	383751	1/23/2021	.33
					Account Total	1,822.55
					Department Total	1,822.55

**County of Adams**  
**Vendor Payment Report**

<u>3161</u>	<u>Animal Shelter Construction</u>	<u>Fund</u>	<u>Voucher</u>	<u>Batch No</u>	<u>GL Date</u>	<u>Amount</u>
	Buildings					
	PCard JE	00004	989953	383751	1/23/2021	699.00
	PCard JE	00004	989953	383751	1/23/2021	354.00
					Account Total	1,053.00
	Gas & Electricity					
	PCard JE	00004	989953	383751	1/23/2021	7,071.08
					Account Total	7,071.08
					Department Total	8,124.08

**County of Adams**  
**Vendor Payment Report**

<u>2051</u>	<u>ANS - Admin &amp; Customer Care</u>	<u>Fund</u>	<u>Voucher</u>	<u>Batch No</u>	<u>GL Date</u>	<u>Amount</u>
	Equipment Rental					
	PCard JE	00001	989953	383751	1/23/2021	173.80
	PCard JE	00001	989953	383751	1/23/2021	21.69
	PCard JE	00001	989953	383751	1/23/2021	48.44
	PCard JE	00001	989953	383751	1/23/2021	173.80
	PCard JE	00001	989953	383751	1/23/2021	34.11
					Account Total	451.84
	Medical Supplies					
	PCard JE	00001	989953	383751	1/23/2021	66.90
					Account Total	66.90
	Membership Dues					
	PCard JE	00001	989953	383751	1/23/2021	900.00
					Account Total	900.00
	Operating Supplies					
	PCard JE	00001	989953	383751	1/23/2021	38.71
	PCard JE	00001	989953	383751	1/23/2021	867.29
	PCard JE	00001	989953	383751	1/23/2021	290.40
	PCard JE	00001	989953	383751	1/23/2021	252.00
	PCard JE	00001	989953	383751	1/23/2021	1,476.65
	PCard JE	00001	989953	383751	1/23/2021	4.99
	PCard JE	00001	989953	383751	1/23/2021	528.28
	PCard JE	00001	989953	383751	1/23/2021	85.65
	PCard JE	00001	989953	383751	1/23/2021	319.85
	PCard JE	00001	989953	383751	1/23/2021	190.60
	PCard JE	00001	989953	383751	1/23/2021	18.15
	PCard JE	00001	989953	383751	1/23/2021	34.16
	PCard JE	00001	989953	383751	1/23/2021	34.16-
	PCard JE	00001	989953	383751	1/23/2021	24.00
					Account Total	4,096.57
	Software					
	PCard JE	00001	989953	383751	1/23/2021	39.00
					Account Total	39.00
	Special Events					
	PCard JE	00001	989953	383751	1/23/2021	43.15

**County of Adams**  
**Vendor Payment Report**

<u>2051</u>	<u>ANS - Admin &amp; Customer Care</u>	<u>Fund</u>	<u>Voucher</u>	<u>Batch No</u>	<u>GL Date</u>	<u>Amount</u>
					Account Total	43.15
					Department Total	5,597.46

**County of Adams**  
**Vendor Payment Report**

<u>2053</u>	<u>ANS - Animal Care</u>	<u>Fund</u>	<u>Voucher</u>	<u>Batch No</u>	<u>GL Date</u>	<u>Amount</u>
	Education & Training					
	PCard JE	00001	989953	383751	1/23/2021	495.00
					Account Total	495.00
	Operating Supplies					
	PCard JE	00001	989953	383751	1/23/2021	99.45
	PCard JE	00001	989953	383751	1/23/2021	42.68
	PCard JE	00001	989953	383751	1/23/2021	76.83
	PCard JE	00001	989953	383751	1/23/2021	26.50
	PCard JE	00001	989953	383751	1/23/2021	44.95
					Account Total	290.41
					Department Total	785.41

**County of Adams**  
**Vendor Payment Report**

<u>2056</u>	<u>ANS - Health Care</u>	<u>Fund</u>	<u>Voucher</u>	<u>Batch No</u>	<u>GL Date</u>	<u>Amount</u>
	Education & Training					
	PCard JE	00001	989953	383751	1/23/2021	124.00
					Account Total	124.00
	Medical Services					
	PCard JE	00001	989953	383751	1/23/2021	210.60
					Account Total	210.60
	Membership Dues					
	PCard JE	00001	989953	383751	1/23/2021	110.00
	PCard JE	00001	989953	383751	1/23/2021	720.00
					Account Total	830.00
	Operating Supplies					
	PCard JE	00001	989953	383751	1/23/2021	43.25
	PCard JE	00001	989953	383751	1/23/2021	90.42
	PCard JE	00001	989953	383751	1/23/2021	15.95
	PCard JE	00001	989953	383751	1/23/2021	94.90
					Account Total	244.52
	Other Repair & Maint					
	PCard JE	00001	989953	383751	1/23/2021	200.00
					Account Total	200.00
	Uniforms & Cleaning					
	PCard JE	00001	989953	383751	1/23/2021	29.98
					Account Total	29.98
					Department Total	1,639.10

**County of Adams**  
**Vendor Payment Report**

<u>2054</u>	<u>ANS-Volunteer &amp; Comm Relations</u>	<u>Fund</u>	<u>Voucher</u>	<u>Batch No</u>	<u>GL Date</u>	<u>Amount</u>
	Operating Supplies					
	PCard JE	00001	989953	383751	1/23/2021	4.99
	PCard JE	00001	989953	383751	1/23/2021	8.15
					Account Total	13.14
	Software and Licensing					
	PCard JE	00001	989953	383751	1/23/2021	876.00
					Account Total	876.00
	Special Events					
	PCard JE	00001	989953	383751	1/23/2021	45.00
	PCard JE	00001	989953	383751	1/23/2021	20.00
					Account Total	65.00
	Uniforms & Cleaning					
	PCard JE	00001	989953	383751	1/23/2021	482.70
					Account Total	482.70
					Department Total	1,436.84

**County of Adams**  
**Vendor Payment Report**

<u>1040</u>	<u>Assessor Administration</u>	<u>Fund</u>	<u>Voucher</u>	<u>Batch No</u>	<u>GL Date</u>	<u>Amount</u>
	Equipment Rental					
	PCard JE	00001	989953	383751	1/23/2021	173.80
	PCard JE	00001	989953	383751	1/23/2021	130.60
	PCard JE	00001	989953	383751	1/23/2021	149.23
	PCard JE	00001	989953	383751	1/23/2021	149.23
	PCard JE	00001	989953	383751	1/23/2021	65.84
	PCard JE	00001	989953	383751	1/23/2021	3.17
	PCard JE	00001	989953	383751	1/23/2021	12.18
	PCard JE	00001	989953	383751	1/23/2021	4.24
	PCard JE	00001	989953	383751	1/23/2021	28.19
	PCard JE	00001	989953	383751	1/23/2021	9.22
	PCard JE	00001	989953	383751	1/23/2021	1.87
	PCard JE	00001	989953	383751	1/23/2021	3.28
	PCard JE	00001	989953	383751	1/23/2021	173.80
	PCard JE	00001	989953	383751	1/23/2021	130.60
	PCard JE	00001	989953	383751	1/23/2021	149.23
	PCard JE	00001	989953	383751	1/23/2021	149.23
	PCard JE	00001	989953	383751	1/23/2021	49.20
	PCard JE	00001	989953	383751	1/23/2021	7.69
	PCard JE	00001	989953	383751	1/23/2021	7.65
	PCard JE	00001	989953	383751	1/23/2021	.63
					Account Total	1,398.88
	Operating Supplies					
	PCard JE	00001	989953	383751	1/23/2021	27.33
	PCard JE	00001	989953	383751	1/23/2021	295.07
	PCard JE	00001	989953	383751	1/23/2021	160.00
	PCard JE	00001	989953	383751	1/23/2021	149.90
	PCard JE	00001	989953	383751	1/23/2021	7.90
					Account Total	640.20
	Other Professional Serv					
	ADAMS COUNTY TREASURER	00001	989814	383573	2/1/2021	1,807.91
					Account Total	1,807.91
	Software and Licensing					
	PCard JE	00001	989953	383751	1/23/2021	171.19
	PCard JE	00001	989953	383751	1/23/2021	542.09



**County of Adams**  
**Vendor Payment Report**

<u>1040</u>	<u>Assessor Administration</u>	<u>Fund</u>	<u>Voucher</u>	<u>Batch No</u>	<u>GL Date</u>	<u>Amount</u>
	PCard JE	00001	989953	383751	1/23/2021	542.09
	PCard JE	00001	989953	383751	1/23/2021	522.50
	PCard JE	00001	989953	383751	1/23/2021	75.00
					Account Total	1,852.87
	Special Events					
	PCard JE	00001	989953	383751	1/23/2021	73.78
					Account Total	73.78
					Department Total	5,773.64

**County of Adams**  
**Vendor Payment Report**

<u>1011</u>	<u>Board of County Commissioners</u>	<u>Fund</u>	<u>Voucher</u>	<u>Batch No</u>	<u>GL Date</u>	<u>Amount</u>
	Business Meetings					
	PCard JE	00001	989953	383751	1/23/2021	807.70
					Account Total	807.70
	Equipment Rental					
	PCard JE	00001	989953	383751	1/23/2021	206.10
	PCard JE	00001	989953	383751	1/23/2021	124.62
	PCard JE	00001	989953	383751	1/23/2021	7.80
	PCard JE	00001	989953	383751	1/23/2021	1.84
	PCard JE	00001	989953	383751	1/23/2021	.52
	PCard JE	00001	989953	383751	1/23/2021	2.69
	PCard JE	00001	989953	383751	1/23/2021	206.10
	PCard JE	00001	989953	383751	1/23/2021	124.62
	PCard JE	00001	989953	383751	1/23/2021	2.32
	PCard JE	00001	989953	383751	1/23/2021	3.46
					Account Total	680.07
	Legal Notices					
	PCard JE	00001	989953	383751	1/23/2021	136.20
	PCard JE	00001	989953	383751	1/23/2021	21.96
	PCard JE	00001	989953	383751	1/23/2021	38.88
	PCard JE	00001	989953	383751	1/23/2021	26.40
					Account Total	223.44
	Membership Dues					
	PCard JE	00001	989953	383751	1/23/2021	305.00
					Account Total	305.00
	Operating Supplies					
	PCard JE	00001	989953	383751	1/23/2021	16.95
	PCard JE	00001	989953	383751	1/23/2021	51.08
					Account Total	68.03
	Printing External					
	PCard JE	00001	989953	383751	1/23/2021	155.00
					Account Total	155.00
	Special Events					
	PCard JE	00001	989953	383751	1/23/2021	500.00
					Account Total	500.00

**County of Adams**  
**Vendor Payment Report**

<u>1011</u>	<u>Board of County Commissioners</u>	<u>Fund</u>	<u>Voucher</u>	<u>Batch No</u>	<u>GL Date</u>	<u>Amount</u>
	Subscrip/Publications					
	PCard JE	00001	989953	383751	1/23/2021	12.95
					Account Total	12.95
					Department Total	<u>2,752.19</u>

**County of Adams**  
**Vendor Payment Report**

<u>1024</u>	<u>Budget Office</u>	<u>Fund</u>	<u>Voucher</u>	<u>Batch No</u>	<u>GL Date</u>	<u>Amount</u>
	Legal Notices					
	PCard JE	00001	989953	383751	1/23/2021	22.44
					Account Total	22.44
	Membership Dues					
	PCard JE	00001	989953	383751	1/23/2021	150.00
	PCard JE	00001	989953	383751	1/23/2021	150.00
					Account Total	300.00
	Operating Supplies					
	PCard JE	00001	989953	383751	1/23/2021	31.15
	PCard JE	00001	989953	383751	1/23/2021	41.41
					Account Total	72.56
					Department Total	395.00

**County of Adams**  
**Vendor Payment Report**

<u>3064</u>	<u>Building Safety</u>	<u>Fund</u>	<u>Voucher</u>	<u>Batch No</u>	<u>GL Date</u>	<u>Amount</u>
	Books					
	PCard JE	00001	989953	383751	1/23/2021	69.99
					Account Total	69.99
	Equipment Rental					
	PCard JE	00001	989953	383751	1/23/2021	173.80
	PCard JE	00001	989953	383751	1/23/2021	124.48
	PCard JE	00001	989953	383751	1/23/2021	4.29
	PCard JE	00001	989953	383751	1/23/2021	173.80
	PCard JE	00001	989953	383751	1/23/2021	6.30
					Account Total	482.67
	Membership Dues					
	PCard JE	00001	989953	383751	1/23/2021	120.00
					Account Total	120.00
	Operating Supplies					
	PCard JE	00001	989953	383751	1/23/2021	12.79
	PCard JE	00001	989953	383751	1/23/2021	13.35
	PCard JE	00001	989953	383751	1/23/2021	17.82
					Account Total	43.96
	Other Communications					
	PCard JE	00001	989953	383751	1/23/2021	623.51
					Account Total	623.51
	Software and Licensing					
	PCard JE	00001	989953	383751	1/23/2021	19.99
					Account Total	19.99
	Travel & Transportation					
	PCard JE	00001	989953	383751	1/23/2021	28.50
	PCard JE	00001	989953	383751	1/23/2021	25.60
	PCard JE	00001	989953	383751	1/23/2021	28.25
	PCard JE	00001	989953	383751	1/23/2021	25.60
					Account Total	107.95
					Department Total	1,468.07

**County of Adams**  
**Vendor Payment Report**

<u>400005007000</u>	<u>Bus Ofc Common Supportive</u>	<u>Fund</u>	<u>Voucher</u>	<u>Batch No</u>	<u>GL Date</u>	<u>Amount</u>
	Minor Equipment					
	PCard JE	00015	989953	383751	1/23/2021	379.88
	PCard JE	00015	989953	383751	1/23/2021	4,876.00
	PCard JE	00015	989953	383751	1/23/2021	309.68
					Account Total	5,565.56
	Operating Supplies					
	PCard JE	00015	989953	383751	1/23/2021	48.99
					Account Total	48.99
					Department Total	5,614.55

**County of Adams**  
**Vendor Payment Report**

<u>306005007000</u>	<u>CA Common Supportive</u>	<u>Fund</u>	<u>Voucher</u>	<u>Batch No</u>	<u>GL Date</u>	<u>Amount</u>
	Equipment Rental					
	PCard JE	00015	989953	383751	1/23/2021	149.23
	PCard JE	00015	989953	383751	1/23/2021	149.23
	PCard JE	00015	989953	383751	1/23/2021	37.55
	PCard JE	00015	989953	383751	1/23/2021	.08
	PCard JE	00015	989953	383751	1/23/2021	17.61
	PCard JE	00015	989953	383751	1/23/2021	2.18
					Account Total	<u>355.88</u>
					Department Total	<u><u>355.88</u></u>

**County of Adams**  
**Vendor Payment Report**

<u>1074</u>	<u>CA- Risk Management</u>	<u>Fund</u>	<u>Voucher</u>	<u>Batch No</u>	<u>GL Date</u>	<u>Amount</u>
	Safety - Equipment					
	AED AUTHORITY	00019	989659	383353	1/28/2021	195.00
					Account Total	195.00
					Department Total	195.00



**County of Adams**  
**Vendor Payment Report**

<u>1043</u>	<u>CA- Social Services IV-D</u>	<u>Fund</u>	<u>Voucher</u>	<u>Batch No</u>	<u>GL Date</u>	<u>Amount</u>
	Books					
	PCard JE	00001	989953	383751	1/23/2021	725.95
					Account Total	725.95
	Equipment Rental					
	PCard JE	00001	989953	383751	1/23/2021	206.10
	PCard JE	00001	989953	383751	1/23/2021	124.62
	PCard JE	00001	989953	383751	1/23/2021	18.57
	PCard JE	00001	989953	383751	1/23/2021	12.84
	PCard JE	00001	989953	383751	1/23/2021	206.10
	PCard JE	00001	989953	383751	1/23/2021	124.62
	PCard JE	00001	989953	383751	1/23/2021	16.36
	PCard JE	00001	989953	383751	1/23/2021	6.65
					Account Total	715.86
	Operating Supplies					
	PCard JE	00001	989953	383751	1/23/2021	11.00
	PCard JE	00001	989953	383751	1/23/2021	23.26
	PCard JE	00001	989953	383751	1/23/2021	31.55
					Account Total	65.81
					Department Total	1,507.62

**County of Adams**  
**Vendor Payment Report**

<u>1044</u>	<u>CA- SS Dependency/Neglect</u>	<u>Fund</u>	<u>Voucher</u>	<u>Batch No</u>	<u>GL Date</u>	<u>Amount</u>
	Business Meetings					
	PCard JE	00001	989953	383751	1/23/2021	16.25
					Account Total	16.25
	Consultant Services					
	PUEBLO COUNTY GOVERNMENT	00001	989930	383685	2/2/2021	930.00
					Account Total	930.00
	Operating Supplies					
	PCard JE	00001	989953	383751	1/23/2021	24.85
					Account Total	24.85
					Department Total	<u>971.10</u>

**County of Adams**  
**Vendor Payment Report**

<u>4</u>	<u>Capital Facilities Fund</u>	<u>Fund</u>	<u>Voucher</u>	<u>Batch No</u>	<u>GL Date</u>	<u>Amount</u>
	Received not Vouchered Clrg					
	REDLAND	00004	990026	383900	2/4/2021	4,650.00
	REDLAND	00004	990026	383900	2/4/2021	262.50
					Account Total	4,912.50
					Department Total	4,912.50

**County of Adams**  
**Vendor Payment Report**

<u>9263</u>	<u>CARES Act Funding</u>	<u>Fund</u>	<u>Voucher</u>	<u>Batch No</u>	<u>GL Date</u>	<u>Amount</u>
	Building Repair & Maint					
	PCard JE	00001	989953	383751	1/23/2021	989.25
					Account Total	989.25
	County Client/Provider					
	COLUMBINE FEDERAL CREDIT UNION	00001	990008	383894	2/4/2021	210.72
	TOSCANA MC JV LLC	00001	990009	383895	2/4/2021	1,299.00
					Account Total	1,509.72
	Operating Supplies					
	ARA INC	00001	989929	383685	2/2/2021	1,894.40
	BOULDER MEDICAL CENTER PC	00001	989074	382172	1/25/2021	2,000.00
	PCard JE	00001	989953	383751	1/23/2021	94.99
	PCard JE	00001	989953	383751	1/23/2021	48.67
	PCard JE	00001	989953	383751	1/23/2021	43.78
	PCard JE	00001	989953	383751	1/23/2021	418.90
	PCard JE	00001	989953	383751	1/23/2021	418.90
	PCard JE	00001	989953	383751	1/23/2021	229.45
	PCard JE	00001	989953	383751	1/23/2021	229.45
	PCard JE	00001	989953	383751	1/23/2021	43.78
	PCard JE	00001	989953	383751	1/23/2021	240.84
	PCard JE	00001	989953	383751	1/23/2021	111.54
					Account Total	5,774.70
	Other Communications					
	PCard JE	00001	989953	383751	1/23/2021	2,091.80
					Account Total	2,091.80
	Other Professional Serv					
	SUNSTATE EQUIPMENT CO LLC	00001	989907	383684	2/2/2021	1,410.00
	SUNSTATE EQUIPMENT CO LLC	00001	989908	383684	2/2/2021	1,675.00
	SUNSTATE EQUIPMENT CO LLC	00001	989909	383684	2/2/2021	3,192.36
					Account Total	6,277.36
					Department Total	16,642.83

**County of Adams**  
**Vendor Payment Report**

<u>4302</u>	<u>CASP Administration</u>	<u>Fund</u>	<u>Voucher</u>	<u>Batch No</u>	<u>GL Date</u>	<u>Amount</u>
	Airport Materials & Supplies					
	PCard JE	00043	989953	383751	1/23/2021	225.00
					Account Total	225.00
	Equipment Rental					
	PCard JE	00043	989953	383751	1/23/2021	155.09
	PCard JE	00043	989953	383751	1/23/2021	124.62
	PCard JE	00043	989953	383751	1/23/2021	11.60
	PCard JE	00043	989953	383751	1/23/2021	.68
	PCard JE	00043	989953	383751	1/23/2021	4.18
	PCard JE	00043	989953	383751	1/23/2021	.08
	PCard JE	00043	989953	383751	1/23/2021	155.09
	PCard JE	00043	989953	383751	1/23/2021	124.62
	PCard JE	00043	989953	383751	1/23/2021	5.74
	PCard JE	00043	989953	383751	1/23/2021	.28
					Account Total	581.98
	Gas & Electricity					
	XCEL ENERGY	00043	989978	383779	1/31/2021	12.67
	XCEL ENERGY	00043	989980	383779	1/31/2021	17.22
					Account Total	29.89
	Janitorial Services					
	PCard JE	00043	989953	383751	1/23/2021	196.15
					Account Total	196.15
	Licenses and Fees					
	PCard JE	00043	989953	383751	1/23/2021	200.00
					Account Total	200.00
	Operating Supplies					
	PCard JE	00043	989953	383751	1/23/2021	9.98
	PCard JE	00043	989953	383751	1/23/2021	47.52
					Account Total	57.50
	Promotion Expense					
	PCard JE	00043	989953	383751	1/23/2021	1,637.50-
	PCard JE	00043	989953	383751	1/23/2021	5,000.00
	PCard JE	00043	989953	383751	1/23/2021	10.00
					Account Total	3,372.50

**County of Adams**  
**Vendor Payment Report**

<u>4302</u>	<u>CASP Administration</u>	<u>Fund</u>	<u>Voucher</u>	<u>Batch No</u>	<u>GL Date</u>	<u>Amount</u>
	Telephone					
	PCard JE	00043	989953	383751	1/23/2021	844.75
					Account Total	<u>844.75</u>
	Water/Sewer/Sanitation					
	SWIMS DISPOSAL	00043	989945	383695	2/2/2021	298.75
					Account Total	<u>298.75</u>
					Department Total	<u><u>5,806.52</u></u>

**County of Adams**  
**Vendor Payment Report**

<u>4308</u>	<u>CASPATCT</u>	<u>Fund</u>	<u>Voucher</u>	<u>Batch No</u>	<u>GL Date</u>	<u>Amount</u>
	Airport Materials & Supplies					
	PCard JE	00043	989953	383751	1/23/2021	2,289.76
					Account Total	2,289.76
	Building Repair & Maint					
	PCard JE	00043	989953	383751	1/23/2021	394.46
					Account Total	394.46
	Gas & Electricity					
	XCEL ENERGY	00043	989979	383779	1/31/2021	14.30
	XCEL ENERGY	00043	989992	383782	1/31/2021	1,834.03
					Account Total	1,848.33
	Telephone					
	PCard JE	00043	989953	383751	1/23/2021	480.07
					Account Total	480.07
					Department Total	5,012.62

**County of Adams**  
**Vendor Payment Report**

<u>4303</u>	<u>CASP FBO</u>	<u>Fund</u>	<u>Voucher</u>	<u>Batch No</u>	<u>GL Date</u>	<u>Amount</u>
	Building Repair & Maint					
	PCard JE	00043	989953	383751	1/23/2021	51.90
	PCard JE	00043	989953	383751	1/23/2021	34.98
					Account Total	86.88
	Equipment Maint & Repair					
	PCard JE	00043	989953	383751	1/23/2021	405.00
					Account Total	405.00
	Gas & Electricity					
	XCEL ENERGY	00043	989625	383346	1/28/2021	63.23
					Account Total	63.23
	Janitorial Services					
	PCard JE	00043	989953	383751	1/23/2021	49.94
					Account Total	49.94
	Jet A Truck					
	TWS AVIATION FUEL SYSTEMS	00043	989946	383695	1/31/2021	320.00
					Account Total	320.00
	Licenses and Fees					
	PCard JE	00043	989953	383751	1/23/2021	480.00
					Account Total	480.00
	Line Materials & Supplies					
	PCard JE	00043	989953	383751	1/23/2021	119.60
	PCard JE	00043	989953	383751	1/23/2021	139.95
					Account Total	259.55
	Operating Supplies					
	PCard JE	00043	989953	383751	1/23/2021	123.01
	PCard JE	00043	989953	383751	1/23/2021	47.52
					Account Total	170.53
	Pilot Supplies					
	PCard JE	00043	989953	383751	1/23/2021	35.95
	PCard JE	00043	989953	383751	1/23/2021	17.07
	PCard JE	00043	989953	383751	1/23/2021	39.45
					Account Total	92.47



**County of Adams**  
**Vendor Payment Report**

<u>4303</u>	<u>CASP FBO</u>	<u>Fund</u>	<u>Voucher</u>	<u>Batch No</u>	<u>GL Date</u>	<u>Amount</u>
	Postage & Freight					
	PCard JE	00043	989953	383751	1/23/2021	35.54
					Account Total	35.54
	Promotion Expense					
	PCard JE	00043	989953	383751	1/23/2021	1,637.50-
	PCard JE	00043	989953	383751	1/23/2021	10.99
					Account Total	1,626.51-
					Department Total	336.63

**County of Adams**  
**Vendor Payment Report**

<u>4304</u>	<u>CASP Operations/Maintenance</u>	<u>Fund</u>	<u>Voucher</u>	<u>Batch No</u>	<u>GL Date</u>	<u>Amount</u>
	Airport Materials & Supplies					
	PCard JE	00043	989953	383751	1/23/2021	149.00
	PCard JE	00043	989953	383751	1/23/2021	25.16
	PCard JE	00043	989953	383751	1/23/2021	26.98
					Account Total	201.14
	Airside Expenses					
	PCard JE	00043	989953	383751	1/23/2021	195.28
					Account Total	195.28
	Building Repair & Maint					
	PCard JE	00043	989953	383751	1/23/2021	171.17
	PCard JE	00043	989953	383751	1/23/2021	172.09
	PCard JE	00043	989953	383751	1/23/2021	228.99
					Account Total	572.25
	Equipment Maint & Repair					
	PCard JE	00043	989953	383751	1/23/2021	57.42
	PCard JE	00043	989953	383751	1/23/2021	189.96
	PCard JE	00043	989953	383751	1/23/2021	158.82
	PCard JE	00043	989953	383751	1/23/2021	22.38
	PCard JE	00043	989953	383751	1/23/2021	105.19
	PCard JE	00043	989953	383751	1/23/2021	78.12
	PCard JE	00043	989953	383751	1/23/2021	267.22
					Account Total	879.11
	Gas & Electricity					
	ROGGEN FARMERS ELEVATOR ASSN	00043	990004	383795	2/3/2021	1,562.24
	ROGGEN FARMERS ELEVATOR ASSN	00043	990005	383795	2/3/2021	336.00
	XCEL ENERGY	00043	989626	383346	1/28/2021	151.58
	XCEL ENERGY	00043	989627	383346	1/28/2021	171.34
	XCEL ENERGY	00043	989628	383346	1/28/2021	519.76
	XCEL ENERGY	00043	989629	383346	1/28/2021	512.84
	XCEL ENERGY	00043	989629	383346	1/28/2021	880.28
	XCEL ENERGY	00043	989629	383346	1/28/2021	222.49-
	XCEL ENERGY	00043	989981	383779	1/31/2021	331.56
	XCEL ENERGY	00043	989981	383779	1/31/2021	264.87-
	XCEL ENERGY	00043	989981	383779	1/31/2021	30.14-

**County of Adams**  
**Vendor Payment Report**

<u>4304</u>	<u>CASP Operations/Maintenance</u>	<u>Fund</u>	<u>Voucher</u>	<u>Batch No</u>	<u>GL Date</u>	<u>Amount</u>
	XCEL ENERGY	00043	989982	383779	1/31/2021	48.13
	XCEL ENERGY	00043	989983	383781	1/31/2021	50.89
	XCEL ENERGY	00043	989984	383781	1/31/2021	65.71
	XCEL ENERGY	00043	989985	383781	1/31/2021	79.30
	XCEL ENERGY	00043	989986	383781	1/31/2021	99.83
	XCEL ENERGY	00043	989987	383781	1/31/2021	143.69
	XCEL ENERGY	00043	989988	383782	1/31/2021	36.31
	XCEL ENERGY	00043	989988	383782	1/31/2021	128.44
	XCEL ENERGY	00043	989989	383782	1/31/2021	1,119.35
	XCEL ENERGY	00043	989989	383782	1/31/2021	285.12-
	XCEL ENERGY	00043	989990	383782	1/31/2021	1,345.82
	XCEL ENERGY	00043	989990	383782	1/31/2021	453.08-
	XCEL ENERGY	00043	989991	383782	1/31/2021	716.60
	XCEL ENERGY	00043	989991	383782	1/31/2021	636.74
					Account Total	7,680.71
	Shop Materials					
	LOTTMAN OIL COMPANY	00043	989941	383694	2/2/2021	594.00
					Account Total	594.00
	Telephone					
	EASTERN SLOPE RURAL TELEPHONE	00043	989943	383695	2/2/2021	131.82
					Account Total	131.82
	Uniforms & Cleaning					
	PCard JE	00043	989953	383751	1/23/2021	43.03
					Account Total	43.03
					Department Total	10,297.34

**County of Adams**  
**Vendor Payment Report**

<u>941018</u>	<u>CDBG 2018/2019</u>	<u>Fund</u>	<u>Voucher</u>	<u>Batch No</u>	<u>GL Date</u>	<u>Amount</u>
	Grants to Other Inst.-Pgm. Cst					
	MANKO SERIVCE INC	00030	989641	383348	1/28/2021	2,383.25
	PINNACLE PEDIATRICS AND INTERN	00030	989870	383663	2/2/2021	3,499.50
	PINNACLE PEDIATRICS AND INTERN	00030	989871	383664	2/2/2021	3,499.50
					Account Total	<u>9,382.25</u>
					Department Total	<u><u>9,382.25</u></u>

**County of Adams**  
**Vendor Payment Report**

<u>1094</u>	<u>CED Administration</u>	<u>Fund</u>	<u>Voucher</u>	<u>Batch No</u>	<u>GL Date</u>	<u>Amount</u>
	Business Meetings					
	PCard JE	00001	989953	383751	1/23/2021	19.99
					Account Total	19.99
	Equipment Rental					
	PCard JE	00001	989953	383751	1/23/2021	156.74
	PCard JE	00001	989953	383751	1/23/2021	60.23
	PCard JE	00001	989953	383751	1/23/2021	21.94
	PCard JE	00001	989953	383751	1/23/2021	156.74
	PCard JE	00001	989953	383751	1/23/2021	20.14
					Account Total	415.79
	Operating Supplies					
	PCard JE	00001	989953	383751	1/23/2021	12.80
	PCard JE	00001	989953	383751	1/23/2021	13.34
	PCard JE	00001	989953	383751	1/23/2021	17.82
					Account Total	43.96
					Department Total	479.74

**County of Adams**  
**Vendor Payment Report**

<u>2035E0102850</u>	<u>Chafee - Independ Living Dir S</u>	<u>Fund</u>	<u>Voucher</u>	<u>Batch No</u>	<u>GL Date</u>	<u>Amount</u>
	County Client/Provider					
	PCard JE	00015	989953	383751	1/23/2021	<u>50.00</u>
					Account Total	<u>50.00</u>
					Department Total	<u><u>50.00</u></u>

**County of Adams**  
**Vendor Payment Report**

<u>307531502300</u>	<u>Child Care Admin</u>	<u>Fund</u>	<u>Voucher</u>	<u>Batch No</u>	<u>GL Date</u>	<u>Amount</u>
	Equipment Rental					
	PCard JE	00015	989953	383751	1/23/2021	281.64
	PCard JE	00015	989953	383751	1/23/2021	173.80
	PCard JE	00015	989953	383751	1/23/2021	136.44
	PCard JE	00015	989953	383751	1/23/2021	.10
	PCard JE	00015	989953	383751	1/23/2021	106.00
	PCard JE	00015	989953	383751	1/23/2021	.04
					Account Total	<u>698.02</u>
					Department Total	<u><u>698.02</u></u>

**County of Adams**  
**Vendor Payment Report**

<u>3050P9999900</u>	<u>Child Support Non-Reimbursable</u>	<u>Fund</u>	<u>Voucher</u>	<u>Batch No</u>	<u>GL Date</u>	<u>Amount</u>
	Special Events					
	PCard JE	00015	989953	383751	1/23/2021	44.00
	PCard JE	00015	989953	383751	1/23/2021	61.84
					Account Total	105.84
					Department Total	105.84



**County of Adams**  
**Vendor Payment Report**

<u>201032001220</u>	<u>Child Welfare 100%</u>	<u>Fund</u>	<u>Voucher</u>	<u>Batch No</u>	<u>GL Date</u>	<u>Amount</u>
	Other Professional Serv					
	PCard JE	00015	989953	383751	1/23/2021	71.96
					Account Total	71.96
					Department Total	71.96

**County of Adams**  
**Vendor Payment Report**

<u>201032001210</u>	<u>Child Welfare 80/20</u>	<u>Fund</u>	<u>Voucher</u>	<u>Batch No</u>	<u>GL Date</u>	<u>Amount</u>
	County Client/Provider					
	PCard JE	00015	989953	383751	1/23/2021	15.00
					Account Total	15.00
	Equipment Rental					
	PCard JE	00015	989953	383751	1/23/2021	281.64
	PCard JE	00015	989953	383751	1/23/2021	281.64
	PCard JE	00015	989953	383751	1/23/2021	281.64
	PCard JE	00015	989953	383751	1/23/2021	281.64
	PCard JE	00015	989953	383751	1/23/2021	167.28
	PCard JE	00015	989953	383751	1/23/2021	155.09
	PCard JE	00015	989953	383751	1/23/2021	184.21
	PCard JE	00015	989953	383751	1/23/2021	184.21
	PCard JE	00015	989953	383751	1/23/2021	184.21
	PCard JE	00015	989953	383751	1/23/2021	184.21
	PCard JE	00015	989953	383751	1/23/2021	156.74
	PCard JE	00015	989953	383751	1/23/2021	130.60
	PCard JE	00015	989953	383751	1/23/2021	149.23
	PCard JE	00015	989953	383751	1/23/2021	149.23
	PCard JE	00015	989953	383751	1/23/2021	124.62
	PCard JE	00015	989953	383751	1/23/2021	130.60
	PCard JE	00015	989953	383751	1/23/2021	17.04
	PCard JE	00015	989953	383751	1/23/2021	51.36
	PCard JE	00015	989953	383751	1/23/2021	66.93
	PCard JE	00015	989953	383751	1/23/2021	65.16
	PCard JE	00015	989953	383751	1/23/2021	31.69
	PCard JE	00015	989953	383751	1/23/2021	2.74
	PCard JE	00015	989953	383751	1/23/2021	13.04
	PCard JE	00015	989953	383751	1/23/2021	2.94
	PCard JE	00015	989953	383751	1/23/2021	28.35
	PCard JE	00015	989953	383751	1/23/2021	10.83
	PCard JE	00015	989953	383751	1/23/2021	11.85
	PCard JE	00015	989953	383751	1/23/2021	21.77
	PCard JE	00015	989953	383751	1/23/2021	.03
	PCard JE	00015	989953	383751	1/23/2021	20.91
	PCard JE	00015	989953	383751	1/23/2021	9.08



**County of Adams**  
**Vendor Payment Report**

<u>201032001210</u>	<u>Child Welfare 80/20</u>	<u>Fund</u>	<u>Voucher</u>	<u>Batch No</u>	<u>GL Date</u>	<u>Amount</u>
	PCard JE	00015	989953	383751	1/23/2021	49.50
	PCard JE	00015	989953	383751	1/23/2021	49.50
	PCard JE	00015	989953	383751	1/23/2021	49.50
	PCard JE	00015	989953	383751	1/23/2021	49.50
	PCard JE	00015	989953	383751	1/23/2021	49.50
	PCard JE	00015	989953	383751	1/23/2021	49.50
	PCard JE	00015	989953	383751	1/23/2021	49.50
					Account Total	1,336.50
	Operating Supplies					
	PCard JE	00015	989953	383751	1/23/2021	981.33
	PCard JE	00015	989953	383751	1/23/2021	52.92
	PCard JE	00015	989953	383751	1/23/2021	49.99
	PCard JE	00015	989953	383751	1/23/2021	79.78
	PCard JE	00015	989953	383751	1/23/2021	413.63
	PCard JE	00015	989953	383751	1/23/2021	413.63-
					Account Total	1,164.02
	Other Professional Serv					
	PCard JE	00015	989953	383751	1/23/2021	139.08
	PCard JE	00015	989953	383751	1/23/2021	99.00
	PCard JE	00015	989953	383751	1/23/2021	99.00
	PCard JE	00015	989953	383751	1/23/2021	99.00
					Account Total	436.08
	Printing External					
	PCard JE	00015	989953	383751	1/23/2021	170.00
	PCard JE	00015	989953	383751	1/23/2021	30.99
	PCard JE	00015	989953	383751	1/23/2021	19.00
					Account Total	219.99
	Travel & Transportation					
	PCard JE	00015	989953	383751	1/23/2021	3,960.00
	PCard JE	00015	989953	383751	1/23/2021	279.90
	PCard JE	00015	989953	383751	1/23/2021	72.00
	PCard JE	00015	989953	383751	1/23/2021	57.90
	PCard JE	00015	989953	383751	1/23/2021	96.13
	PCard JE	00015	989953	383751	1/23/2021	34.00
	PCard JE	00015	989953	383751	1/23/2021	123.03

**County of Adams**  
**Vendor Payment Report**

<u>201032001210</u>	<u>Child Welfare 80/20</u>	<u>Fund</u>	<u>Voucher</u>	<u>Batch No</u>	<u>GL Date</u>	<u>Amount</u>
	PCard JE	00015	989953	383751	1/23/2021	8.74
	PCard JE	00015	989953	383751	1/23/2021	13.85
	PCard JE	00015	989953	383751	1/23/2021	10.95
	PCard JE	00015	989953	383751	1/23/2021	118.10
	PCard JE	00015	989953	383751	1/23/2021	118.10
					Account Total	4,892.70
	Vital Statistics - Birth,					
	PCard JE	00015	989953	383751	1/23/2021	10.00
	PCard JE	00015	989953	383751	1/23/2021	15.00
					Account Total	25.00
					Department Total	11,828.60

**County of Adams**  
**Vendor Payment Report**

<u>201032101578</u>	<u>Child Welfare 90/10 (SB15-242)</u>	<u>Fund</u>	<u>Voucher</u>	<u>Batch No</u>	<u>GL Date</u>	<u>Amount</u>
	Other Professional Serv					
	PCard JE	00015	989953	383751	1/23/2021	<u>35.98</u>
					Account Total	<u>35.98</u>
					Department Total	<u><u>35.98</u></u>

**County of Adams**  
**Vendor Payment Report**

<u>1020</u>	<u>CLK Administration</u>	<u>Fund</u>	<u>Voucher</u>	<u>Batch No</u>	<u>GL Date</u>	<u>Amount</u>
	Education & Training					
	PCard JE	00001	989953	383751	1/23/2021	199.00
					Account Total	199.00
	Operating Supplies					
	PCard JE	00001	989953	383751	1/23/2021	28.08
	PCard JE	00001	989953	383751	1/23/2021	344.21
	PCard JE	00001	989953	383751	1/23/2021	8.01
	PCard JE	00001	989953	383751	1/23/2021	958.08
	PCard JE	00001	989953	383751	1/23/2021	301.31
	PCard JE	00001	989953	383751	1/23/2021	9.22
	PCard JE	00001	989953	383751	1/23/2021	68.82
					Account Total	1,717.73
					Department Total	1,916.73

**County of Adams**  
**Vendor Payment Report**

<u>1022</u>	<u>CLK Elections</u>	<u>Fund</u>	<u>Voucher</u>	<u>Batch No</u>	<u>GL Date</u>	<u>Amount</u>
	Education & Training					
	PCard JE	00001	989953	383751	1/23/2021	498.00
					Account Total	498.00
	Equipment Rental					
	PCard JE	00001	989953	383751	1/23/2021	167.28
	PCard JE	00001	989953	383751	1/23/2021	184.21
	PCard JE	00001	989953	383751	1/23/2021	184.21
	PCard JE	00001	989953	383751	1/23/2021	130.60
	PCard JE	00001	989953	383751	1/23/2021	124.62
	PCard JE	00001	989953	383751	1/23/2021	124.62
	PCard JE	00001	989953	383751	1/23/2021	27.19
	PCard JE	00001	989953	383751	1/23/2021	722.66
	PCard JE	00001	989953	383751	1/23/2021	14.75
	PCard JE	00001	989953	383751	1/23/2021	4.09
	PCard JE	00001	989953	383751	1/23/2021	.64
	PCard JE	00001	989953	383751	1/23/2021	4.92
	PCard JE	00001	989953	383751	1/23/2021	133.18
	PCard JE	00001	989953	383751	1/23/2021	9.82
	PCard JE	00001	989953	383751	1/23/2021	1.61
	PCard JE	00001	989953	383751	1/23/2021	.90
	PCard JE	00001	989953	383751	1/23/2021	167.28
	PCard JE	00001	989953	383751	1/23/2021	184.21
	PCard JE	00001	989953	383751	1/23/2021	184.21
	PCard JE	00001	989953	383751	1/23/2021	130.60
	PCard JE	00001	989953	383751	1/23/2021	124.62
	PCard JE	00001	989953	383751	1/23/2021	124.62
	PCard JE	00001	989953	383751	1/23/2021	1.84
	PCard JE	00001	989953	383751	1/23/2021	79.75
	PCard JE	00001	989953	383751	1/23/2021	724.77
	PCard JE	00001	989953	383751	1/23/2021	11.93
	PCard JE	00001	989953	383751	1/23/2021	1.93
	PCard JE	00001	989953	383751	1/23/2021	.25
					Account Total	3,571.31
	Operating Supplies					
	PCard JE	00001	989953	383751	1/23/2021	47.69



**County of Adams**  
**Vendor Payment Report**

<u>1022</u>	<u>CLK Elections</u>	<u>Fund</u>	<u>Voucher</u>	<u>Batch No</u>	<u>GL Date</u>	<u>Amount</u>
	PCard JE	00001	989953	383751	1/23/2021	25.17
	PCard JE	00001	989953	383751	1/23/2021	69.95
					Account Total	<u>142.81</u>
	Other Communications					
	PCard JE	00001	989953	383751	1/23/2021	4,067.03
					Account Total	<u>4,067.03</u>
	Postage & Freight					
	PCard JE	00001	989953	383751	1/23/2021	23.25
	PCard JE	00001	989953	383751	1/23/2021	15.50
	PCard JE	00001	989953	383751	1/23/2021	7.75
					Account Total	<u>46.50</u>
					Department Total	<u><u>8,325.65</u></u>

**County of Adams**  
**Vendor Payment Report**

<u>1023</u>	<u>CLK Motor Vehicle</u>	<u>Fund</u>	<u>Voucher</u>	<u>Batch No</u>	<u>GL Date</u>	<u>Amount</u>
	Education & Training					
	PCard JE	00001	989953	383751	1/23/2021	10.00
	PCard JE	00001	989953	383751	1/23/2021	10.00
	PCard JE	00001	989953	383751	1/23/2021	10.00
					Account Total	30.00
	Equipment Rental					
	PCard JE	00001	989953	383751	1/23/2021	155.09
	PCard JE	00001	989953	383751	1/23/2021	155.09
	PCard JE	00001	989953	383751	1/23/2021	155.09
	PCard JE	00001	989953	383751	1/23/2021	155.09
	PCard JE	00001	989953	383751	1/23/2021	124.62
	PCard JE	00001	989953	383751	1/23/2021	6.87
	PCard JE	00001	989953	383751	1/23/2021	5.45
	PCard JE	00001	989953	383751	1/23/2021	202.88
	PCard JE	00001	989953	383751	1/23/2021	6.42
	PCard JE	00001	989953	383751	1/23/2021	1.60
	PCard JE	00001	989953	383751	1/23/2021	17.50
	PCard JE	00001	989953	383751	1/23/2021	4.65
	PCard JE	00001	989953	383751	1/23/2021	80.84
	PCard JE	00001	989953	383751	1/23/2021	.45
	PCard JE	00001	989953	383751	1/23/2021	.15
	PCard JE	00001	989953	383751	1/23/2021	155.09
	PCard JE	00001	989953	383751	1/23/2021	155.09
	PCard JE	00001	989953	383751	1/23/2021	155.09
	PCard JE	00001	989953	383751	1/23/2021	124.62
	PCard JE	00001	989953	383751	1/23/2021	96.11
	PCard JE	00001	989953	383751	1/23/2021	44.69
	PCard JE	00001	989953	383751	1/23/2021	232.63
	PCard JE	00001	989953	383751	1/23/2021	3.86
	PCard JE	00001	989953	383751	1/23/2021	1.37
					Account Total	2,195.43
	Operating Supplies					
	PCard JE	00001	989953	383751	1/23/2021	1,383.00
	PCard JE	00001	989953	383751	1/23/2021	19.99

**County of Adams**  
**Vendor Payment Report**

<u>1023</u>	<u>CLK Motor Vehicle</u>	<u>Fund</u>	<u>Voucher</u>	<u>Batch No</u>	<u>GL Date</u>	<u>Amount</u>
	PCard JE	00001	989953	383751	1/23/2021	89.08
	PCard JE	00001	989953	383751	1/23/2021	87.80
					Account Total	<u>1,579.87</u>
	Repair & Maint Supplies					
	PCard JE	00001	989953	383751	1/23/2021	118.44
	PCard JE	00001	989953	383751	1/23/2021	60.90
	PCard JE	00001	989953	383751	1/23/2021	59.98
	PCard JE	00001	989953	383751	1/23/2021	128.80
					Account Total	<u>368.12</u>
	Subscrip/Publications					
	PCard JE	00001	989953	383751	1/23/2021	131.91
					Account Total	<u>131.91</u>
					Department Total	<u><u>4,305.33</u></u>

**County of Adams**  
**Vendor Payment Report**

<u>1021</u>	<u>CLK Recording</u>	<u>Fund</u>	<u>Voucher</u>	<u>Batch No</u>	<u>GL Date</u>	<u>Amount</u>
	Equipment Rental					
	PCard JE	00001	989953	383751	1/23/2021	155.09
	PCard JE	00001	989953	383751	1/23/2021	173.80
	PCard JE	00001	989953	383751	1/23/2021	149.23
	PCard JE	00001	989953	383751	1/23/2021	4.07
	PCard JE	00001	989953	383751	1/23/2021	11.16
	PCard JE	00001	989953	383751	1/23/2021	.71
	PCard JE	00001	989953	383751	1/23/2021	19.43
	PCard JE	00001	989953	383751	1/23/2021	15.47
	PCard JE	00001	989953	383751	1/23/2021	.11
	PCard JE	00001	989953	383751	1/23/2021	155.09
	PCard JE	00001	989953	383751	1/23/2021	173.80
	PCard JE	00001	989953	383751	1/23/2021	149.23
	PCard JE	00001	989953	383751	1/23/2021	32.15
	PCard JE	00001	989953	383751	1/23/2021	9.46
	PCard JE	00001	989953	383751	1/23/2021	.78
					Account Total	1,049.58
	Membership Dues					
	PCard JE	00001	989953	383751	1/23/2021	330.00
					Account Total	330.00
	Operating Supplies					
	PCard JE	00001	989953	383751	1/23/2021	507.42
	PCard JE	00001	989953	383751	1/23/2021	12.59
					Account Total	520.01
	Other Communications					
	PCard JE	00001	989953	383751	1/23/2021	131.57
					Account Total	131.57
					Department Total	2,031.16

**County of Adams**  
**Vendor Payment Report**

<u>3060</u>	<u>Code Compliance</u>	<u>Fund</u>	<u>Voucher</u>	<u>Batch No</u>	<u>GL Date</u>	<u>Amount</u>
	Equipment Rental					
	PCard JE	00001	989953	383751	1/23/2021	173.80
	PCard JE	00001	989953	383751	1/23/2021	258.63
	PCard JE	00001	989953	383751	1/23/2021	145.80
	PCard JE	00001	989953	383751	1/23/2021	173.80
	PCard JE	00001	989953	383751	1/23/2021	61.62
					Account Total	813.65
	Membership Dues					
	PCard JE	00001	989953	383751	1/23/2021	45.00
	PCard JE	00001	989953	383751	1/23/2021	45.00
	PCard JE	00001	989953	383751	1/23/2021	45.00
	PCard JE	00001	989953	383751	1/23/2021	45.00
					Account Total	180.00
	Operating Supplies					
	PCard JE	00001	989953	383751	1/23/2021	46.98
	PCard JE	00001	989953	383751	1/23/2021	12.67
	PCard JE	00001	989953	383751	1/23/2021	28.29
	PCard JE	00001	989953	383751	1/23/2021	12.21
	PCard JE	00001	989953	383751	1/23/2021	14.67
	PCard JE	00001	989953	383751	1/23/2021	246.08
	PCard JE	00001	989953	383751	1/23/2021	124.07
					Account Total	484.97
	Other Professional Serv					
	PCard JE	00001	989953	383751	1/23/2021	119.70
	PCard JE	00001	989953	383751	1/23/2021	143.67
					Account Total	263.37
	Telephone					
	PCard JE	00001	989953	383751	1/23/2021	529.03
					Account Total	529.03
	Uniforms & Cleaning					
	PCard JE	00001	989953	383751	1/23/2021	760.95
					Account Total	760.95
					Department Total	3,031.97

**County of Adams**  
**Vendor Payment Report**

<u>43</u>	<u>Colorado Air &amp; Space Port</u>	<u>Fund</u>	<u>Voucher</u>	<u>Batch No</u>	<u>GL Date</u>	<u>Amount</u>
	Received not Vouchered Clrg					
	CITY SERVICEVALCON LLC	00043	990110	384040	2/5/2021	25,189.72
	DBT TRANSPORTATION SERVICES LL	00043	990036	383900	2/4/2021	787.50
	DBT TRANSPORTATION SERVICES LL	00043	990037	383900	2/4/2021	416.67
	DBT TRANSPORTATION SERVICES LL	00043	990038	383900	2/4/2021	787.50
	DBT TRANSPORTATION SERVICES LL	00043	990039	383900	2/4/2021	416.67
					Account Total	27,598.06
					Department Total	27,598.06

**County of Adams**  
**Vendor Payment Report**

<u>300005007100</u>	<u>Com Supp Staff Dev</u>	<u>Fund</u>	<u>Voucher</u>	<u>Batch No</u>	<u>GL Date</u>	<u>Amount</u>
	Other Professional Serv					
	PCard JE	00015	989953	383751	1/23/2021	<u>78.66</u>
					Account Total	<u>78.66</u>
					Department Total	<u><u>78.66</u></u>

**County of Adams**  
**Vendor Payment Report**

<u>2040</u>	<u>Comm Safety &amp; Wellbeing Admin</u>	<u>Fund</u>	<u>Voucher</u>	<u>Batch No</u>	<u>GL Date</u>	<u>Amount</u>
	Membership Dues					
	PCard JE	00001	989953	383751	1/23/2021	216.90
	PCard JE	00001	989953	383751	1/23/2021	5.00
	PCard JE	00001	989953	383751	1/23/2021	165.00
					Account Total	386.90
	Operating Supplies					
	PCard JE	00001	989953	383751	1/23/2021	34.99
	PCard JE	00001	989953	383751	1/23/2021	18.95
	PCard JE	00001	989953	383751	1/23/2021	34.99
	PCard JE	00001	989953	383751	1/23/2021	330.53
					Account Total	419.46
	Other Professional Serv					
	PCard JE	00001	989953	383751	1/23/2021	1,290.00
					Account Total	1,290.00
					Department Total	2,096.36



**County of Adams**  
**Vendor Payment Report**

<u>1010</u>	<u>Communications</u>	<u>Fund</u>	<u>Voucher</u>	<u>Batch No</u>	<u>GL Date</u>	<u>Amount</u>
	Advertising					
	PCard JE	00001	989953	383751	1/23/2021	200.00
					Account Total	200.00
	Equipment Rental					
	PCard JE	00001	989953	383751	1/23/2021	156.74
	PCard JE	00001	989953	383751	1/23/2021	.01
	PCard JE	00001	989953	383751	1/23/2021	156.74
	PCard JE	00001	989953	383751	1/23/2021	.50
					Account Total	313.99
	Minor Equipment					
	PCard JE	00001	989953	383751	1/23/2021	129.00
					Account Total	129.00
	Multi-Media Services					
	PCard JE	00001	989953	383751	1/23/2021	150.00
	PCard JE	00001	989953	383751	1/23/2021	2.50
	PCard JE	00001	989953	383751	1/23/2021	2.50
	PCard JE	00001	989953	383751	1/23/2021	9.99
	PCard JE	00001	989953	383751	1/23/2021	2,094.40
	PCard JE	00001	989953	383751	1/23/2021	2.50
	PCard JE	00001	989953	383751	1/23/2021	2.50
	PCard JE	00001	989953	383751	1/23/2021	27.50
	PCard JE	00001	989953	383751	1/23/2021	2.50
	PCard JE	00001	989953	383751	1/23/2021	2.50
					Account Total	2,296.89
	Other Communications					
	PCard JE	00001	989953	383751	1/23/2021	12.95
					Account Total	12.95
	Software					
	PCard JE	00001	989953	383751	1/23/2021	52.99
					Account Total	52.99
	Special Events					
	PCard JE	00001	989953	383751	1/23/2021	311.96
					Account Total	311.96

**County of Adams**  
**Vendor Payment Report**

<u>1010</u>	<u>Communications</u>	<u>Fund</u>	<u>Voucher</u>	<u>Batch No</u>	<u>GL Date</u>	<u>Amount</u>
	Subscrip/Publications					
	PCard JE	00001	989953	383751	1/23/2021	87.99
					Account Total	87.99
					Department Total	3,405.77

**County of Adams**  
**Vendor Payment Report**

<u>9275</u>	<u>Community Corrections</u>	<u>Fund</u>	<u>Voucher</u>	<u>Batch No</u>	<u>GL Date</u>	<u>Amount</u>
	Business Meetings					
	PCard JE	00001	989953	383751	1/23/2021	55.22
	PCard JE	00001	989953	383751	1/23/2021	18.10
					Account Total	73.32
	Equipment Rental					
	PCard JE	00001	989953	383751	1/23/2021	206.10
	PCard JE	00001	989953	383751	1/23/2021	4.64
	PCard JE	00001	989953	383751	1/23/2021	39.67
	PCard JE	00001	989953	383751	1/23/2021	206.10
	PCard JE	00001	989953	383751	1/23/2021	4.68
					Account Total	461.19
					Department Total	534.51

**County of Adams**  
**Vendor Payment Report**

<u>9264</u>	<u>Community Recovery</u>	<u>Fund</u>	<u>Voucher</u>	<u>Batch No</u>	<u>GL Date</u>	<u>Amount</u>
	Operating Supplies					
	PCard JE	00001	989953	383751	1/23/2021	94.80
					Account Total	94.80
	Printing External					
	PCard JE	00001	989953	383751	1/23/2021	800.00
	PCard JE	00001	989953	383751	1/23/2021	1,429.55
					Account Total	2,229.55
	Repair & Maint Supplies					
	PCard JE	00001	989953	383751	1/23/2021	391.16
	PCard JE	00001	989953	383751	1/23/2021	9.97
					Account Total	401.13
					Department Total	<u>2,725.48</u>

**County of Adams**  
**Vendor Payment Report**

<u>2055</u>	<u>Control/Enforcement</u>	<u>Fund</u>	<u>Voucher</u>	<u>Batch No</u>	<u>GL Date</u>	<u>Amount</u>
	Telephone					
	PCard JE	00001	989953	383751	1/23/2021	479.53
					Account Total	479.53
					Department Total	479.53

**County of Adams**  
**Vendor Payment Report**

<u>1041</u>	<u>County Assessor</u>	<u>Fund</u>	<u>Voucher</u>	<u>Batch No</u>	<u>GL Date</u>	<u>Amount</u>
	Car Washes					
	PCard JE	00001	989953	383751	1/23/2021	6.00
	PCard JE	00001	989953	383751	1/23/2021	8.00
	PCard JE	00001	989953	383751	1/23/2021	6.00
					Account Total	<u>20.00</u>
	Postage & Freight					
	MAIL MASTERS OF COLORADO	00001	989813	383573	2/1/2021	1,800.00
					Account Total	<u>1,800.00</u>
					Department Total	<u><u>1,820.00</u></u>

**County of Adams**  
**Vendor Payment Report**

<u>1013</u>	<u>County Attorney</u>	<u>Fund</u>	<u>Voucher</u>	<u>Batch No</u>	<u>GL Date</u>	<u>Amount</u>
	Books					
	PCard JE	00001	989953	383751	1/23/2021	480.00
					Account Total	480.00
	Business Meetings					
	PCard JE	00001	989953	383751	1/23/2021	16.25
	PCard JE	00001	989953	383751	1/23/2021	49.75
	PCard JE	00001	989953	383751	1/23/2021	65.06
					Account Total	131.06
	Consultant Services					
	ELKUS & SISSON PC AND	00001	989658	383353	1/28/2021	3,424.33
	SGR	00001	989655	383353	1/28/2021	1,793.00
	SGR	00001	989657	383353	1/28/2021	3,347.18
					Account Total	8,564.51
	Court Reporting Transcripts					
	PCard JE	00001	989953	383751	1/23/2021	235.80
	PCard JE	00001	989953	383751	1/23/2021	135.40
					Account Total	371.20
	Education & Training					
	COLO COUNTY ATTORNEYS ASSN	00001	989926	383685	2/2/2021	600.00
					Account Total	600.00
	Equipment Rental					
	PCard JE	00001	989953	383751	1/23/2021	281.64
	PCard JE	00001	989953	383751	1/23/2021	130.60
	PCard JE	00001	989953	383751	1/23/2021	124.74
	PCard JE	00001	989953	383751	1/23/2021	189.15
	PCard JE	00001	989953	383751	1/23/2021	.19
	PCard JE	00001	989953	383751	1/23/2021	188.27
	PCard JE	00001	989953	383751	1/23/2021	281.64
	PCard JE	00001	989953	383751	1/23/2021	130.60
	PCard JE	00001	989953	383751	1/23/2021	124.74
	PCard JE	00001	989953	383751	1/23/2021	57.81
	PCard JE	00001	989953	383751	1/23/2021	1.34
					Account Total	1,510.72
	Membership Dues					

**County of Adams**  
**Vendor Payment Report**

<u>1013</u>	<u>County Attorney</u>	<u>Fund</u>	<u>Voucher</u>	<u>Batch No</u>	<u>GL Date</u>	<u>Amount</u>
	PCard JE	00001	989953	383751	1/23/2021	80.00
	PCard JE	00001	989953	383751	1/23/2021	80.00
					Account Total	160.00
	Messenger/Delivery Service					
	FEDERAL EXPRESS CO	00001	989927	383685	2/2/2021	35.50
	PCard JE	00001	989953	383751	1/23/2021	17.20
					Account Total	52.70
	Minor Equipment					
	PCard JE	00001	989953	383751	1/23/2021	19.99
					Account Total	19.99
	Operating Supplies					
	PCard JE	00001	989953	383751	1/23/2021	23.99
					Account Total	23.99
	Other Professional Serv					
	PCard JE	00001	989953	383751	1/23/2021	5,150.00
					Account Total	5,150.00
					Department Total	17,064.17



**County of Adams**  
**Vendor Payment Report**

<u>2031</u>	<u>County Coroner</u>	<u>Fund</u>	<u>Voucher</u>	<u>Batch No</u>	<u>GL Date</u>	<u>Amount</u>
	Business Meetings					
	PCard JE	00001	989953	383751	1/23/2021	169.05
	PCard JE	00001	989953	383751	1/23/2021	229.23
	PCard JE	00001	989953	383751	1/23/2021	29.94
	PCard JE	00001	989953	383751	1/23/2021	47.30
					Account Total	475.52
	Education & Training					
	PCard JE	00001	989953	383751	1/23/2021	485.00
					Account Total	485.00
	Equipment Rental					
	PCard JE	00001	989953	383751	1/23/2021	155.09
	PCard JE	00001	989953	383751	1/23/2021	149.23
	PCard JE	00001	989953	383751	1/23/2021	35.30
	PCard JE	00001	989953	383751	1/23/2021	16.07
	PCard JE	00001	989953	383751	1/23/2021	9.99
	PCard JE	00001	989953	383751	1/23/2021	15.06
	PCard JE	00001	989953	383751	1/23/2021	155.09
	PCard JE	00001	989953	383751	1/23/2021	149.23
	PCard JE	00001	989953	383751	1/23/2021	26.58
	PCard JE	00001	989953	383751	1/23/2021	15.96
					Account Total	727.60
	Medical Services					
	CARUSO JAMES LOUIS	00001	989824	383578	2/1/2021	5,375.00
	CINA & CINA FORENSIC CONSULTIN	00001	989823	383577	2/1/2021	13,200.00
					Account Total	18,575.00
	Membership Dues					
	PCard JE	00001	989953	383751	1/23/2021	165.00
					Account Total	165.00
	Minor Equipment					
	PCard JE	00001	989953	383751	1/23/2021	336.17
	PCard JE	00001	989953	383751	1/23/2021	96.66
	PCard JE	00001	989953	383751	1/23/2021	3,020.37
					Account Total	3,453.20
	Operating Supplies					

**County of Adams**  
**Vendor Payment Report**

<u>2031</u>	<u>County Coroner</u>	<u>Fund</u>	<u>Voucher</u>	<u>Batch No</u>	<u>GL Date</u>	<u>Amount</u>
	PCard JE	00001	989953	383751	1/23/2021	530.93
	PCard JE	00001	989953	383751	1/23/2021	39.54
	PCard JE	00001	989953	383751	1/23/2021	165.70
	PCard JE	00001	989953	383751	1/23/2021	52.50
	PCard JE	00001	989953	383751	1/23/2021	137.87
	PCard JE	00001	989953	383751	1/23/2021	126.83
	PCard JE	00001	989953	383751	1/23/2021	40.50
	PCard JE	00001	989953	383751	1/23/2021	284.12
	PCard JE	00001	989953	383751	1/23/2021	66.79
	PCard JE	00001	989953	383751	1/23/2021	187.82
	PCard JE	00001	989953	383751	1/23/2021	51.38
	PCard JE	00001	989953	383751	1/23/2021	121.19
	PCard JE	00001	989953	383751	1/23/2021	416.30
	PCard JE	00001	989953	383751	1/23/2021	113.92
	PCard JE	00001	989953	383751	1/23/2021	13.99
	PCard JE	00001	989953	383751	1/23/2021	706.49
	PCard JE	00001	989953	383751	1/23/2021	144.90
	PCard JE	00001	989953	383751	1/23/2021	106.45
	PCard JE	00001	989953	383751	1/23/2021	124.99
	PCard JE	00001	989953	383751	1/23/2021	148.53
	PCard JE	00001	989953	383751	1/23/2021	59.23
	PCard JE	00001	989953	383751	1/23/2021	51.48
	PCard JE	00001	989953	383751	1/23/2021	5.07
	PCard JE	00001	989953	383751	1/23/2021	135.00
	PCard JE	00001	989953	383751	1/23/2021	165.00
	PCard JE	00001	989953	383751	1/23/2021	625.00
					Account Total	4,621.52
	Other Communications					
	PCard JE	00001	989953	383751	1/23/2021	2,772.85
	PCard JE	00001	989953	383751	1/23/2021	420.86
	PCard JE	00001	989953	383751	1/23/2021	683.07
					Account Total	3,876.78
	Other Professional Serv					
	ARIAS REBECCA M	00001	989772	383566	2/1/2021	1,890.00
	ARIAS REBECCA M	00001	989773	383566	2/1/2021	2,289.00

**County of Adams**  
**Vendor Payment Report**

<u>2031</u>	<u>County Coroner</u>	<u>Fund</u>	<u>Voucher</u>	<u>Batch No</u>	<u>GL Date</u>	<u>Amount</u>
	JAZOWSKI KAREN	00001	989830	383644	2/2/2021	3,550.00
	OCHS CRYSTAL	00001	989774	383567	2/1/2021	870.00
	PCard JE	00001	989953	383751	1/23/2021	34.00
	PCard JE	00001	989953	383751	1/23/2021	163.00
	PCard JE	00001	989953	383751	1/23/2021	137.00
	PCard JE	00001	989953	383751	1/23/2021	270.00
	PCard JE	00001	989953	383751	1/23/2021	191.75
	PCard JE	00001	989953	383751	1/23/2021	422.21
					Account Total	9,816.96
	Postage & Freight					
	PCard JE	00001	989953	383751	1/23/2021	12.22
	PCard JE	00001	989953	383751	1/23/2021	33.67
	PCard JE	00001	989953	383751	1/23/2021	36.84
					Account Total	82.73
	Travel & Transportation					
	PCard JE	00001	989953	383751	1/23/2021	25.30
	PCard JE	00001	989953	383751	1/23/2021	28.20
	PCard JE	00001	989953	383751	1/23/2021	37.20
					Account Total	90.70
					Department Total	42,370.01

**County of Adams**  
**Vendor Payment Report**

<u>1012</u>	<u>County Manager</u>	<u>Fund</u>	<u>Voucher</u>	<u>Batch No</u>	<u>GL Date</u>	<u>Amount</u>
	Equipment Rental					
	PCard JE	00001	989953	383751	1/23/2021	173.80
	PCard JE	00001	989953	383751	1/23/2021	1.62
	PCard JE	00001	989953	383751	1/23/2021	1.06
	PCard JE	00001	989953	383751	1/23/2021	173.80
	PCard JE	00001	989953	383751	1/23/2021	5.42
					Account Total	355.70
	Membership Dues					
	PCard JE	00001	989953	383751	1/23/2021	12.99
	PCard JE	00001	989953	383751	1/23/2021	90.00
					Account Total	102.99
	Operating Supplies					
	PCard JE	00001	989953	383751	1/23/2021	56.40
	PCard JE	00001	989953	383751	1/23/2021	97.58
	PCard JE	00001	989953	383751	1/23/2021	1,074.16
	PCard JE	00001	989953	383751	1/23/2021	151.90
					Account Total	1,380.04
	Special Events					
	PCard JE	00001	989953	383751	1/23/2021	158.00
	PCard JE	00001	989953	383751	1/23/2021	109.70
	PCard JE	00001	989953	383751	1/23/2021	56.40
	PCard JE	00001	989953	383751	1/23/2021	22.70
	PCard JE	00001	989953	383751	1/23/2021	142.47
					Account Total	489.27
	Subscrip/Publications					
	PCard JE	00001	989953	383751	1/23/2021	240.00
					Account Total	240.00
					Department Total	2,568.00

**County of Adams**  
**Vendor Payment Report**

<u>1031</u>	<u>County Treasurer</u>	<u>Fund</u>	<u>Voucher</u>	<u>Batch No</u>	<u>GL Date</u>	<u>Amount</u>
	Equipment Rental					
	PCard JE	00001	989953	383751	1/23/2021	155.09
	PCard JE	00001	989953	383751	1/23/2021	130.60
	PCard JE	00001	989953	383751	1/23/2021	10.17
	PCard JE	00001	989953	383751	1/23/2021	10.32
	PCard JE	00001	989953	383751	1/23/2021	8.92
	PCard JE	00001	989953	383751	1/23/2021	6.43
	PCard JE	00001	989953	383751	1/23/2021	155.09
	PCard JE	00001	989953	383751	1/23/2021	130.60
	PCard JE	00001	989953	383751	1/23/2021	13.06
	PCard JE	00001	989953	383751	1/23/2021	11.78
					Account Total	632.06
	Operating Supplies					
	PCard JE	00001	989953	383751	1/23/2021	150.00
	PCard JE	00001	989953	383751	1/23/2021	216.90
	PCard JE	00001	989953	383751	1/23/2021	150.00
	PCard JE	00001	989953	383751	1/23/2021	145.02
	PCard JE	00001	989953	383751	1/23/2021	72.68
	PCard JE	00001	989953	383751	1/23/2021	33.32
	PCard JE	00001	989953	383751	1/23/2021	168.25
	PCard JE	00001	989953	383751	1/23/2021	221.96
	PCard JE	00001	989953	383751	1/23/2021	43.64
					Account Total	1,201.77
	Other Communications					
	VERIZON	00001	989734	383465	1/29/2021	62.49
	VERIZON	00001	989734	383465	1/29/2021	52.49
	VERIZON	00001	989735	383467	1/29/2021	204.07
	VERIZON	00001	989735	383467	1/29/2021	52.64
					Account Total	371.69
					Department Total	2,205.52

**County of Adams**  
**Vendor Payment Report**

<u>951016</u>	<u>CSBG</u>	<u>Fund</u>	<u>Voucher</u>	<u>Batch No</u>	<u>GL Date</u>	<u>Amount</u>
	Operating Supplies					
	PCard JE	00034	989953	383751	1/23/2021	47.76
	PCard JE	00034	989953	383751	1/23/2021	162.64
					Account Total	<u>210.40</u>
					Department Total	<u><u>210.40</u></u>

**County of Adams**  
**Vendor Payment Report**

<u>6021</u>	<u>CT- Trails- Plan/Design Const</u>	<u>Fund</u>	<u>Voucher</u>	<u>Batch No</u>	<u>GL Date</u>	<u>Amount</u>
	Infrastruc Rep & Maint					
	PCard JE	00024	989953	383751	1/23/2021	452.24
	PCard JE	00024	989953	383751	1/23/2021	2,055.00
	PCard JE	00024	989953	383751	1/23/2021	1,675.00
	PCard JE	00024	989953	383751	1/23/2021	1,675.00
					Account Total	5,857.24
	Operating Supplies					
	PCard JE	00024	989953	383751	1/23/2021	329.80
					Account Total	329.80
	Repair & Maint Supplies					
	PCard JE	00024	989953	383751	1/23/2021	62.87
					Account Total	62.87
					Department Total	6,249.91

**County of Adams**  
**Vendor Payment Report**

<u>9248</u>	<u>Culture Services</u>	<u>Fund</u>	<u>Voucher</u>	<u>Batch No</u>	<u>GL Date</u>	<u>Amount</u>
	Software and Licensing PCard JE	00001	989953	383751	1/23/2021	789.79
					Account Total	789.79
					Department Total	789.79



**County of Adams**  
**Vendor Payment Report**

<u>2010P1009900</u>	<u>CW Admin Client Spec Non Reimb</u>	<u>Fund</u>	<u>Voucher</u>	<u>Batch No</u>	<u>GL Date</u>	<u>Amount</u>
	Travel & Transportation					
	PCard JE	00015	989953	383751	1/23/2021	<u>86.96</u>
					Account Total	<u>86.96</u>
					Department Total	<u><u>86.96</u></u>

**County of Adams**  
**Vendor Payment Report**

<u>2010P9999900</u>	<u>CW Admin Non Reimb</u>	<u>Fund</u>	<u>Voucher</u>	<u>Batch No</u>	<u>GL Date</u>	<u>Amount</u>
	Operating Supplies					
	PCard JE	00015	989953	383751	1/23/2021	82.75
	PCard JE	00015	989953	383751	1/23/2021	150.00
	PCard JE	00015	989953	383751	1/23/2021	10.85
	PCard JE	00015	989953	383751	1/23/2021	7.17
	PCard JE	00015	989953	383751	1/23/2021	48.75
					Account Total	299.52
	Travel & Transportation					
	PCard JE	00015	989953	383751	1/23/2021	57.90
	PCard JE	00015	989953	383751	1/23/2021	60.00
	PCard JE	00015	989953	383751	1/23/2021	29.60
	PCard JE	00015	989953	383751	1/23/2021	30.00
	PCard JE	00015	989953	383751	1/23/2021	15.00
	PCard JE	00015	989953	383751	1/23/2021	118.10
	PCard JE	00015	989953	383751	1/23/2021	84.00
					Account Total	394.60
					Department Total	694.12

**County of Adams**  
**Vendor Payment Report**

<u>2010W5031501</u>	<u>CW Cares Act</u>	<u>Fund</u>	<u>Voucher</u>	<u>Batch No</u>	<u>GL Date</u>	<u>Amount</u>
	Operating Supplies					
	PCard JE	00015	989953	383751	1/23/2021	<u>102.37</u>
					Account Total	<u>102.37</u>
					Department Total	<u><u>102.37</u></u>

**County of Adams**  
**Vendor Payment Report**

<u>200005501000</u>	<u>CW Director Soc Serv Support</u>	<u>Fund</u>	<u>Voucher</u>	<u>Batch No</u>	<u>GL Date</u>	<u>Amount</u>
	Software and Licensing					
	PCard JE	00015	989953	383751	1/23/2021	576.00
	PCard JE	00015	989953	383751	1/23/2021	879.56
					Account Total	<u>1,455.56</u>
					Department Total	<u><u>1,455.56</u></u>

**County of Adams**  
**Vendor Payment Report**

<u>9261</u>	<u>DA- Diversion Project</u>	<u>Fund</u>	<u>Voucher</u>	<u>Batch No</u>	<u>GL Date</u>	<u>Amount</u>
	Medical Services					
	PCard JE	00001	989953	383751	1/23/2021	80.00
					Account Total	80.00
	Software and Licensing					
	PCard JE	00001	989953	383751	1/23/2021	311.56
	PCard JE	00001	989953	383751	1/23/2021	18.00
	PCard JE	00001	989953	383751	1/23/2021	14.99
	PCard JE	00001	989953	383751	1/23/2021	132.00
					Account Total	476.55
					Department Total	556.55

**County of Adams**  
**Vendor Payment Report**

<u>100005007000</u>	<u>Dept Director Common Supportiv</u>	<u>Fund</u>	<u>Voucher</u>	<u>Batch No</u>	<u>GL Date</u>	<u>Amount</u>
	Equipment Rental					
	PCard JE	00015	989953	383751	1/23/2021	184.21
	PCard JE	00015	989953	383751	1/23/2021	16.22
	PCard JE	00015	989953	383751	1/23/2021	16.67
					Account Total	217.10
	Operating Supplies					
	PCard JE	00015	989953	383751	1/23/2021	90.00
	PCard JE	00015	989953	383751	1/23/2021	199.00
					Account Total	289.00
	Software and Licensing					
	PCard JE	00015	989953	383751	1/23/2021	14.99
					Account Total	14.99
					Department Total	521.09

**County of Adams**  
**Vendor Payment Report**

<u>1000P9999900</u>	<u>Dept Director Non-Reimbursable</u>	<u>Fund</u>	<u>Voucher</u>	<u>Batch No</u>	<u>GL Date</u>	<u>Amount</u>
	Equipment Rental					
	PCard JE	00015	989953	383751	1/23/2021	281.64
	PCard JE	00015	989953	383751	1/23/2021	281.64
	PCard JE	00015	989953	383751	1/23/2021	281.64
	PCard JE	00015	989953	383751	1/23/2021	281.64
	PCard JE	00015	989953	383751	1/23/2021	281.64
	PCard JE	00015	989953	383751	1/23/2021	281.64
	PCard JE	00015	989953	383751	1/23/2021	281.64
	PCard JE	00015	989953	383751	1/23/2021	281.64
	PCard JE	00015	989953	383751	1/23/2021	281.64
	PCard JE	00015	989953	383751	1/23/2021	281.64
	PCard JE	00015	989953	383751	1/23/2021	281.64
	PCard JE	00015	989953	383751	1/23/2021	281.64
	PCard JE	00015	989953	383751	1/23/2021	281.64
	PCard JE	00015	989953	383751	1/23/2021	167.28
	PCard JE	00015	989953	383751	1/23/2021	167.28
	PCard JE	00015	989953	383751	1/23/2021	167.28
	PCard JE	00015	989953	383751	1/23/2021	155.09
	PCard JE	00015	989953	383751	1/23/2021	155.09
	PCard JE	00015	989953	383751	1/23/2021	155.09
	PCard JE	00015	989953	383751	1/23/2021	156.74
	PCard JE	00015	989953	383751	1/23/2021	173.80
	PCard JE	00015	989953	383751	1/23/2021	173.80
	PCard JE	00015	989953	383751	1/23/2021	173.80
	PCard JE	00015	989953	383751	1/23/2021	184.21
	PCard JE	00015	989953	383751	1/23/2021	184.21
	PCard JE	00015	989953	383751	1/23/2021	184.21
	PCard JE	00015	989953	383751	1/23/2021	184.21
	PCard JE	00015	989953	383751	1/23/2021	184.21
	PCard JE	00015	989953	383751	1/23/2021	184.21
	PCard JE	00015	989953	383751	1/23/2021	184.21
	PCard JE	00015	989953	383751	1/23/2021	184.21
	PCard JE	00015	989953	383751	1/23/2021	184.21
	PCard JE	00015	989953	383751	1/23/2021	156.74
	PCard JE	00015	989953	383751	1/23/2021	156.74
	PCard JE	00015	989953	383751	1/23/2021	156.74

**County of Adams**  
**Vendor Payment Report**

<u>1000P9999900</u>	<u>Dept Director Non-Reimbursable</u>	<u>Fund</u>	<u>Voucher</u>	<u>Batch No</u>	<u>GL Date</u>	<u>Amount</u>
	PCard JE	00015	989953	383751	1/23/2021	156.74
	PCard JE	00015	989953	383751	1/23/2021	156.74
	PCard JE	00015	989953	383751	1/23/2021	173.80
	PCard JE	00015	989953	383751	1/23/2021	124.62
	PCard JE	00015	989953	383751	1/23/2021	124.62
	PCard JE	00015	989953	383751	1/23/2021	124.62
	PCard JE	00015	989953	383751	1/23/2021	124.62
	PCard JE	00015	989953	383751	1/23/2021	130.60
	PCard JE	00015	989953	383751	1/23/2021	130.60
	PCard JE	00015	989953	383751	1/23/2021	149.23
	PCard JE	00015	989953	383751	1/23/2021	149.23
	PCard JE	00015	989953	383751	1/23/2021	149.23
	PCard JE	00015	989953	383751	1/23/2021	149.23
	PCard JE	00015	989953	383751	1/23/2021	149.23
	PCard JE	00015	989953	383751	1/23/2021	149.23
	PCard JE	00015	989953	383751	1/23/2021	130.60
	PCard JE	00015	989953	383751	1/23/2021	149.23
	PCard JE	00015	989953	383751	1/23/2021	149.23
	PCard JE	00015	989953	383751	1/23/2021	149.23
	PCard JE	00015	989953	383751	1/23/2021	149.23
	PCard JE	00015	989953	383751	1/23/2021	124.62
	PCard JE	00015	989953	383751	1/23/2021	124.62
	PCard JE	00015	989953	383751	1/23/2021	149.23
	PCard JE	00015	989953	383751	1/23/2021	149.23
	PCard JE	00015	989953	383751	1/23/2021	130.60
	PCard JE	00015	989953	383751	1/23/2021	130.60
	PCard JE	00015	989953	383751	1/23/2021	130.60
	PCard JE	00015	989953	383751	1/23/2021	26.92
	PCard JE	00015	989953	383751	1/23/2021	152.62
	PCard JE	00015	989953	383751	1/23/2021	1.32
	PCard JE	00015	989953	383751	1/23/2021	203.06
	PCard JE	00015	989953	383751	1/23/2021	29.03
	PCard JE	00015	989953	383751	1/23/2021	10.44
	PCard JE	00015	989953	383751	1/23/2021	84.76
	PCard JE	00015	989953	383751	1/23/2021	61.57
	PCard JE	00015	989953	383751	1/23/2021	31.05
	PCard JE	00015	989953	383751	1/23/2021	19.63



**County of Adams**  
**Vendor Payment Report**

<u>1000P9999900</u>	<u>Dept Director Non-Reimbursable</u>	<u>Fund</u>	<u>Voucher</u>	<u>Batch No</u>	<u>GL Date</u>	<u>Amount</u>
	PCard JE	00015	989953	383751	1/23/2021	20.95
	PCard JE	00015	989953	383751	1/23/2021	29.56
	PCard JE	00015	989953	383751	1/23/2021	73.04
	PCard JE	00015	989953	383751	1/23/2021	.02
	PCard JE	00015	989953	383751	1/23/2021	.14
	PCard JE	00015	989953	383751	1/23/2021	38.62
	PCard JE	00015	989953	383751	1/23/2021	7.64
	PCard JE	00015	989953	383751	1/23/2021	13.52
	PCard JE	00015	989953	383751	1/23/2021	.06
	PCard JE	00015	989953	383751	1/23/2021	99.88
	PCard JE	00015	989953	383751	1/23/2021	4.61
	PCard JE	00015	989953	383751	1/23/2021	.01
	PCard JE	00015	989953	383751	1/23/2021	12.79
	PCard JE	00015	989953	383751	1/23/2021	2.66
	PCard JE	00015	989953	383751	1/23/2021	.12
	PCard JE	00015	989953	383751	1/23/2021	29.71
	PCard JE	00015	989953	383751	1/23/2021	83.10
	PCard JE	00015	989953	383751	1/23/2021	.32
	PCard JE	00015	989953	383751	1/23/2021	.07
	PCard JE	00015	989953	383751	1/23/2021	10.33
	PCard JE	00015	989953	383751	1/23/2021	1.82
	PCard JE	00015	989953	383751	1/23/2021	.58
	PCard JE	00015	989953	383751	1/23/2021	7.64
	PCard JE	00015	989953	383751	1/23/2021	19.43
	PCard JE	00015	989953	383751	1/23/2021	.50
	PCard JE	00015	989953	383751	1/23/2021	3.66
	PCard JE	00015	989953	383751	1/23/2021	3.07
	PCard JE	00015	989953	383751	1/23/2021	21.14
	PCard JE	00015	989953	383751	1/23/2021	8.21
	PCard JE	00015	989953	383751	1/23/2021	.59
	PCard JE	00015	989953	383751	1/23/2021	.17
	PCard JE	00015	989953	383751	1/23/2021	13.99
	PCard JE	00015	989953	383751	1/23/2021	18.39
	PCard JE	00015	989953	383751	1/23/2021	.05
	PCard JE	00015	989953	383751	1/23/2021	.14
	PCard JE	00015	989953	383751	1/23/2021	6.14

**County of Adams**  
**Vendor Payment Report**

<u>1000P9999900</u>	<u>Dept Director Non-Reimbursable</u>	<u>Fund</u>	<u>Voucher</u>	<u>Batch No</u>	<u>GL Date</u>	<u>Amount</u>
	PCard JE	00015	989953	383751	1/23/2021	1.37
	PCard JE	00015	989953	383751	1/23/2021	.09
	PCard JE	00015	989953	383751	1/23/2021	.68
					Account Total	12,250.02
	ISP Services					
	PCard JE	00015	989953	383751	1/23/2021	169.84
					Account Total	169.84
	Operating Supplies					
	PCard JE	00015	989953	383751	1/23/2021	475.17
	PCard JE	00015	989953	383751	1/23/2021	38.03
	PCard JE	00015	989953	383751	1/23/2021	279.59
	PCard JE	00015	989953	383751	1/23/2021	213.00
	PCard JE	00015	989953	383751	1/23/2021	67.92
	PCard JE	00015	989953	383751	1/23/2021	90.66
	PCard JE	00015	989953	383751	1/23/2021	57.21
	PCard JE	00015	989953	383751	1/23/2021	85.63
	PCard JE	00015	989953	383751	1/23/2021	111.81
	PCard JE	00015	989953	383751	1/23/2021	171.81
	PCard JE	00015	989953	383751	1/23/2021	228.82
	PCard JE	00015	989953	383751	1/23/2021	270.45
	PCard JE	00015	989953	383751	1/23/2021	60.00
	PCard JE	00015	989953	383751	1/23/2021	241.20
	PCard JE	00015	989953	383751	1/23/2021	546.62
	PCard JE	00015	989953	383751	1/23/2021	116.91
					Account Total	3,054.83
					Department Total	15,474.69

**County of Adams**  
**Vendor Payment Report**

<u>1051</u>	<u>District Attorney</u>	<u>Fund</u>	<u>Voucher</u>	<u>Batch No</u>	<u>GL Date</u>	<u>Amount</u>
	Computers					
	PCard JE	00001	989953	383751	1/23/2021	150.00
	PCard JE	00001	989953	383751	1/23/2021	27.99
	PCard JE	00001	989953	383751	1/23/2021	220.44
	PCard JE	00001	989953	383751	1/23/2021	11.99
					Account Total	410.42
	Education & Training					
	PCard JE	00001	989953	383751	1/23/2021	500.00-
	PCard JE	00001	989953	383751	1/23/2021	75.00
					Account Total	425.00-
	Equipment Rental					
	PCard JE	00001	989953	383751	1/23/2021	434.52
					Account Total	434.52
	Membership Dues					
	PCard JE	00001	989953	383751	1/23/2021	13,347.00
					Account Total	13,347.00
	Operating Supplies					
	PCard JE	00001	989953	383751	1/23/2021	460.26
	PCard JE	00001	989953	383751	1/23/2021	466.40
	PCard JE	00001	989953	383751	1/23/2021	14.79
	PCard JE	00001	989953	383751	1/23/2021	179.80
	PCard JE	00001	989953	383751	1/23/2021	34.68
	PCard JE	00001	989953	383751	1/23/2021	257.82
	PCard JE	00001	989953	383751	1/23/2021	134.10
	PCard JE	00001	989953	383751	1/23/2021	14.79
	PCard JE	00001	989953	383751	1/23/2021	9.79
	PCard JE	00001	989953	383751	1/23/2021	47.60
	PCard JE	00001	989953	383751	1/23/2021	76.72
					Account Total	1,696.75
	Other Communications					
	PCard JE	00001	989953	383751	1/23/2021	80.06
	PCard JE	00001	989953	383751	1/23/2021	97.99
					Account Total	178.05
	Other Professional Serv					

**County of Adams**  
**Vendor Payment Report**

<u>1051</u>	<u>District Attorney</u>	<u>Fund</u>	<u>Voucher</u>	<u>Batch No</u>	<u>GL Date</u>	<u>Amount</u>
	PCard JE	00001	989953	383751	1/23/2021	19.95
	PCard JE	00001	989953	383751	1/23/2021	76.18
	PCard JE	00001	989953	383751	1/23/2021	12.74
	PCard JE	00001	989953	383751	1/23/2021	537.20
					Account Total	646.07
	Postage & Freight					
	PCard JE	00001	989953	383751	1/23/2021	52.70
	PCard JE	00001	989953	383751	1/23/2021	14.60
					Account Total	67.30
	Software and Licensing					
	PCard JE	00001	989953	383751	1/23/2021	595.00
	PCard JE	00001	989953	383751	1/23/2021	3,758.70
	PCard JE	00001	989953	383751	1/23/2021	1,108.15
	PCard JE	00001	989953	383751	1/23/2021	1,840.66
					Account Total	7,302.51
	Special Events					
	PCard JE	00001	989953	383751	1/23/2021	75.00
					Account Total	75.00
	Subscrip/Publications					
	PCard JE	00001	989953	383751	1/23/2021	11.99
					Account Total	11.99
					Department Total	23,744.61

**County of Adams**  
**Vendor Payment Report**

<u>7041</u>	<u>Economic Development Center</u>	<u>Fund</u>	<u>Voucher</u>	<u>Batch No</u>	<u>GL Date</u>	<u>Amount</u>
	Membership Dues					
	PCard JE	00001	989953	383751	1/23/2021	1,060.00
	PCard JE	00001	989953	383751	1/23/2021	200.00
	PCard JE	00001	989953	383751	1/23/2021	200.00
	PCard JE	00001	989953	383751	1/23/2021	200.00
	PCard JE	00001	989953	383751	1/23/2021	200.00
					Account Total	1,860.00
	Operating Supplies					
	PCard JE	00001	989953	383751	1/23/2021	13.35
	PCard JE	00001	989953	383751	1/23/2021	17.83
					Account Total	31.18
	Other Communications					
	PCard JE	00001	989953	383751	1/23/2021	19.99
					Account Total	19.99
					Department Total	1,911.17

**County of Adams**  
**Vendor Payment Report**

<u>2041</u>	<u>Emerg Mgmt - Administration</u>	<u>Fund</u>	<u>Voucher</u>	<u>Batch No</u>	<u>GL Date</u>	<u>Amount</u>
	Equipment Rental					
	PCard JE	00001	989953	383751	1/23/2021	187.18
	PCard JE	00001	989953	383751	1/23/2021	124.62
	PCard JE	00001	989953	383751	1/23/2021	187.18
	PCard JE	00001	989953	383751	1/23/2021	124.62
					Account Total	623.60
	Maintenance Contracts					
	PCard JE	00001	989953	383751	1/23/2021	519.75
					Account Total	519.75
	Minor Equipment					
	PCard JE	00001	989953	383751	1/23/2021	110.00
	PCard JE	00001	989953	383751	1/23/2021	5,400.00
					Account Total	5,510.00
	Operating Supplies					
	PCard JE	00001	989953	383751	1/23/2021	110.94
					Account Total	110.94
	Other Communications					
	PCard JE	00001	989953	383751	1/23/2021	49.60
	PCard JE	00001	989953	383751	1/23/2021	36.46
					Account Total	86.06
	Other Professional Serv					
	PCard JE	00001	989953	383751	1/23/2021	3,600.00
	PCard JE	00001	989953	383751	1/23/2021	3,600.00-
					Account Total	7,200.00
	Telephone					
	PCard JE	00001	989953	383751	1/23/2021	330.59
					Account Total	330.59
					Department Total	7,180.94

**County of Adams**  
**Vendor Payment Report**

<u>1191</u>	<u>Environmental Programs</u>	<u>Fund</u>	<u>Voucher</u>	<u>Batch No</u>	<u>GL Date</u>	<u>Amount</u>
	Other Communications					
	PCard JE	00001	989953	383751	1/23/2021	187.47
					Account Total	187.47
	Travel & Transportation					
	PCard JE	00001	989953	383751	1/23/2021	19.99
					Account Total	19.99
					Department Total	207.46

**County of Adams**  
**Vendor Payment Report**

<u>6</u>	<u>Equipment Service Fund</u>	<u>Fund</u>	<u>Voucher</u>	<u>Batch No</u>	<u>GL Date</u>	<u>Amount</u>
	Received not Vouchered Clrg					
	BEARCOM WIRELESS WORLDWIDE	00006	990066	383900	2/4/2021	17,307.03
	DANIELS LONG CHEVROLET	00006	990054	383900	2/4/2021	19,470.00
	FLEX FLEET RENTAL LLC	00006	990069	383900	2/4/2021	5,040.00
	INSIGHT AUTO GLASS LLC	00006	990063	383900	2/4/2021	183.62
	INSIGHT AUTO GLASS LLC	00006	990064	383900	2/4/2021	40.00
	INSIGHT AUTO GLASS LLC	00006	990065	383900	2/4/2021	209.24
	PRECISE MRM LLC	00006	990068	383900	2/4/2021	5,592.00
	SAM HILL OIL INC	00006	990050	383900	2/4/2021	10,460.12
	SAM HILL OIL INC	00006	990070	383900	2/4/2021	2,163.50
	SAM HILL OIL INC	00006	990055	383900	2/4/2021	14,568.14
	SAM HILL OIL INC	00006	990056	383900	2/4/2021	5,933.75
	SILL TERHAR MOTORS INC	00006	990067	383900	2/4/2021	26,063.00
	THE GOODYEAR TIRE AND RUBBER C	00006	990057	383900	2/4/2021	2,472.20
	THE GOODYEAR TIRE AND RUBBER C	00006	990058	383900	2/4/2021	1,726.16
	THE GOODYEAR TIRE AND RUBBER C	00006	990059	383900	2/4/2021	587.79
	THE GOODYEAR TIRE AND RUBBER C	00006	990060	383900	2/4/2021	1,042.00
	THE GOODYEAR TIRE AND RUBBER C	00006	990061	383900	2/4/2021	84.00
	WEX BANK	00006	990062	383900	2/4/2021	1,148.91
					Account Total	114,091.46
					Department Total	114,091.46



**County of Adams**  
**Vendor Payment Report**

<u>9243</u>	<u>Extension - Family &amp; Consumer</u>	<u>Fund</u>	<u>Voucher</u>	<u>Batch No</u>	<u>GL Date</u>	<u>Amount</u>
	Other Communications					
	PCard JE	00001	989953	383751	1/23/2021	41.15
					Account Total	41.15
					Department Total	41.15

**County of Adams**  
**Vendor Payment Report**

<u>9240</u>	<u>Extension - Horticulture</u>	<u>Fund</u>	<u>Voucher</u>	<u>Batch No</u>	<u>GL Date</u>	<u>Amount</u>
	Other Communications					
	PCard JE	00001	989953	383751	1/23/2021	<u>41.15</u>
					Account Total	<u>41.15</u>
					Department Total	<u><u>41.15</u></u>

**County of Adams**  
**Vendor Payment Report**

<u>9244</u>	<u>Extension- 4-H/Youth</u>	<u>Fund</u>	<u>Voucher</u>	<u>Batch No</u>	<u>GL Date</u>	<u>Amount</u>
	Operating Supplies					
	PCard JE	00001	989953	383751	1/23/2021	90.00
	PCard JE	00001	989953	383751	1/23/2021	45.62
	PCard JE	00001	989953	383751	1/23/2021	2.99
	PCard JE	00001	989953	383751	1/23/2021	20.99
	PCard JE	00001	989953	383751	1/23/2021	21.17
	PCard JE	00001	989953	383751	1/23/2021	38.88
	PCard JE	00001	989953	383751	1/23/2021	16.99
					Account Total	236.64
	Other Communications					
	PCard JE	00001	989953	383751	1/23/2021	123.45
					Account Total	123.45
	Postage & Freight					
	PCard JE	00001	989953	383751	1/23/2021	7.60
					Account Total	7.60
	Printing External					
	PCard JE	00001	989953	383751	1/23/2021	3.50
	PCard JE	00001	989953	383751	1/23/2021	42.70
	PCard JE	00001	989953	383751	1/23/2021	49.44
	PCard JE	00001	989953	383751	1/23/2021	29.65
					Account Total	125.29
					Department Total	492.98

**County of Adams**  
**Vendor Payment Report**

<u>9241</u>	<u>Extension- Administration</u>	<u>Fund</u>	<u>Voucher</u>	<u>Batch No</u>	<u>GL Date</u>	<u>Amount</u>
	Equipment Rental					
	PCard JE	00001	989953	383751	1/23/2021	173.80
	PCard JE	00001	989953	383751	1/23/2021	124.62
	PCard JE	00001	989953	383751	1/23/2021	60.62
	PCard JE	00001	989953	383751	1/23/2021	.98
	PCard JE	00001	989953	383751	1/23/2021	100.09
	PCard JE	00001	989953	383751	1/23/2021	2.28
	PCard JE	00001	989953	383751	1/23/2021	173.80
	PCard JE	00001	989953	383751	1/23/2021	124.62
	PCard JE	00001	989953	383751	1/23/2021	44.02
	PCard JE	00001	989953	383751	1/23/2021	4.07
					Account Total	808.90
	Operating Supplies					
	PCard JE	00001	989953	383751	1/23/2021	19.31
					Account Total	19.31
	Other Communications					
	PCard JE	00001	989953	383751	1/23/2021	137.33
					Account Total	137.33
					Department Total	965.54

**County of Adams**  
**Vendor Payment Report**

<u>1014</u>	<u>Finance</u>	<u>Fund</u>	<u>Voucher</u>	<u>Batch No</u>	<u>GL Date</u>	<u>Amount</u>
	Equipment Rental					
	PCard JE	00001	989953	383751	1/23/2021	281.64
	PCard JE	00001	989953	383751	1/23/2021	35.52
	PCard JE	00001	989953	383751	1/23/2021	25.03
	PCard JE	00001	989953	383751	1/23/2021	281.64
	PCard JE	00001	989953	383751	1/23/2021	.94
	PCard JE	00001	989953	383751	1/23/2021	41.87
					Account Total	666.64
	Membership Dues					
	PCard JE	00001	989953	383751	1/23/2021	1,495.00
					Account Total	1,495.00
	Operating Supplies					
	PCard JE	00001	989953	383751	1/23/2021	99.02
					Account Total	99.02
	Postage & Freight					
	FEDEX	00001	989954	383753	2/3/2021	40.85
					Account Total	40.85
	Printing External					
	PCard JE	00001	989953	383751	1/23/2021	150.00
					Account Total	150.00
					Department Total	2,451.51

**County of Adams**  
**Vendor Payment Report**

<u>1018</u>	<u>Finance General Accounting</u>	<u>Fund</u>	<u>Voucher</u>	<u>Batch No</u>	<u>GL Date</u>	<u>Amount</u>
	Legal Notices					
	PCard JE	00001	989953	383751	1/23/2021	300.60
					Account Total	<u>300.60</u>
	Operating Supplies					
	PCard JE	00001	989953	383751	1/23/2021	32.95
	PCard JE	00001	989953	383751	1/23/2021	444.08
	PCard JE	00001	989953	383751	1/23/2021	177.68
	PCard JE	00001	989953	383751	1/23/2021	717.95
	PCard JE	00001	989953	383751	1/23/2021	2.66
					Account Total	<u>1,375.32</u>
					Department Total	<u><u>1,675.92</u></u>

**County of Adams**  
**Vendor Payment Report**

<u>1017</u>	<u>Finance Purchasing</u>	<u>Fund</u>	<u>Voucher</u>	<u>Batch No</u>	<u>GL Date</u>	<u>Amount</u>
	Advertising					
	PCard JE	00001	989953	383751	1/23/2021	160.50
					Account Total	160.50
	Education & Training					
	PCard JE	00001	989953	383751	1/23/2021	342.00
					Account Total	342.00
	Equipment Rental					
	PCard JE	00001	989953	383751	1/23/2021	184.21
	PCard JE	00001	989953	383751	1/23/2021	4.31
	PCard JE	00001	989953	383751	1/23/2021	3.03
	PCard JE	00001	989953	383751	1/23/2021	184.21
	PCard JE	00001	989953	383751	1/23/2021	2.93
					Account Total	378.69
	Membership Dues					
	PCard JE	00001	989953	383751	1/23/2021	120.00
	PCard JE	00001	989953	383751	1/23/2021	71.00
	PCard JE	00001	989953	383751	1/23/2021	10.00
					Account Total	201.00
	Operating Supplies					
	PCard JE	00001	989953	383751	1/23/2021	31.88
					Account Total	31.88
					Department Total	1,114.07

**County of Adams**  
**Vendor Payment Report**

<u>9111</u>	<u>Fleet - Admin</u>	<u>Fund</u>	<u>Voucher</u>	<u>Batch No</u>	<u>GL Date</u>	<u>Amount</u>
	Auto Physical Damage					
	PCard JE	00006	989953	383751	1/23/2021	446.17
					Account Total	446.17
	Equipment Rental					
	PCard JE	00006	989953	383751	1/23/2021	167.58
					Account Total	167.58
	Fuel, Gas & Oil					
	PCard JE	00006	989953	383751	1/23/2021	215.49
	PCard JE	00006	989953	383751	1/23/2021	72.04
	PCard JE	00006	989953	383751	1/23/2021	117.66
					Account Total	405.19
	Heavy Equipment					
	PCard JE	00006	989953	383751	1/23/2021	637.00
					Account Total	637.00
	Oil					
	PCard JE	00006	989953	383751	1/23/2021	250.00
	PCard JE	00006	989953	383751	1/23/2021	40.48
	PCard JE	00006	989953	383751	1/23/2021	4,080.55
					Account Total	4,371.03
	Travel & Transportation					
	PCard JE	00006	989953	383751	1/23/2021	6.70
	PCard JE	00006	989953	383751	1/23/2021	36.65
					Account Total	43.35
	Vehicles & Equipment					
	PCard JE	00006	989953	383751	1/23/2021	2,640.50
					Account Total	2,640.50
					Department Total	<u>8,710.82</u>



**County of Adams**  
**Vendor Payment Report**

<u>9114</u>	<u>Fleet - Commerce City</u>	<u>Fund</u>	<u>Voucher</u>	<u>Batch No</u>	<u>GL Date</u>	<u>Amount</u>
	Building Repair & Maint					
	PCard JE	00006	989953	383751	1/23/2021	106.85
					Account Total	106.85
	Equipment Rental					
	PCard JE	00006	989953	383751	1/23/2021	155.09
	PCard JE	00006	989953	383751	1/23/2021	22.62
	PCard JE	00006	989953	383751	1/23/2021	12.05
	PCard JE	00006	989953	383751	1/23/2021	155.09
	PCard JE	00006	989953	383751	1/23/2021	27.75
					Account Total	372.60
	Operating Supplies					
	PCard JE	00006	989953	383751	1/23/2021	100.98
	PCard JE	00006	989953	383751	1/23/2021	116.79
	PCard JE	00006	989953	383751	1/23/2021	310.27
	PCard JE	00006	989953	383751	1/23/2021	97.02
	PCard JE	00006	989953	383751	1/23/2021	68.58
	PCard JE	00006	989953	383751	1/23/2021	17.56
	PCard JE	00006	989953	383751	1/23/2021	17.56
	PCard JE	00006	989953	383751	1/23/2021	19.34
	PCard JE	00006	989953	383751	1/23/2021	57.50
	PCard JE	00006	989953	383751	1/23/2021	46.70
	PCard JE	00006	989953	383751	1/23/2021	61.20
	PCard JE	00006	989953	383751	1/23/2021	241.07
	PCard JE	00006	989953	383751	1/23/2021	335.14
	PCard JE	00006	989953	383751	1/23/2021	66.78
	PCard JE	00006	989953	383751	1/23/2021	8.21
	PCard JE	00006	989953	383751	1/23/2021	99.32
	PCard JE	00006	989953	383751	1/23/2021	16.25-
					Account Total	1,647.77
	Software and Licensing					
	PCard JE	00006	989953	383751	1/23/2021	783.21
					Account Total	783.21
	Uniforms & Cleaning					
	PCard JE	00006	989953	383751	1/23/2021	163.42

**County of Adams**  
**Vendor Payment Report**

<u>9114</u>	<u>Fleet - Commerce City</u>	<u>Fund</u>	<u>Voucher</u>	<u>Batch No</u>	<u>GL Date</u>	<u>Amount</u>
	PCard JE	00006	989953	383751	1/23/2021	152.62
	PCard JE	00006	989953	383751	1/23/2021	152.62
					Account Total	468.66
	Vehicle Parts & Supplies					
	PCard JE	00006	989953	383751	1/23/2021	622.89
	PCard JE	00006	989953	383751	1/23/2021	374.90
	PCard JE	00006	989953	383751	1/23/2021	1,411.02
	PCard JE	00006	989953	383751	1/23/2021	6,608.94
	PCard JE	00006	989953	383751	1/23/2021	5,279.43
					Account Total	14,297.18
	Vehicle Repair & Maint					
	PCard JE	00006	989953	383751	1/23/2021	1,333.37
	PCard JE	00006	989953	383751	1/23/2021	135.00
	PCard JE	00006	989953	383751	1/23/2021	302.90
	PCard JE	00006	989953	383751	1/23/2021	225.00
	PCard JE	00006	989953	383751	1/23/2021	75.00
	PCard JE	00006	989953	383751	1/23/2021	75.00
	PCard JE	00006	989953	383751	1/23/2021	200.00
	PCard JE	00006	989953	383751	1/23/2021	844.39
	PCard JE	00006	989953	383751	1/23/2021	187.99
	PCard JE	00006	989953	383751	1/23/2021	18.48
	PCard JE	00006	989953	383751	1/23/2021	80.00
	PCard JE	00006	989953	383751	1/23/2021	80.00
	PCard JE	00006	989953	383751	1/23/2021	325.00
	PCard JE	00006	989953	383751	1/23/2021	46.80
	PCard JE	00006	989953	383751	1/23/2021	125.00
	PCard JE	00006	989953	383751	1/23/2021	164.00
	PCard JE	00006	989953	383751	1/23/2021	95.00
	PCard JE	00006	989953	383751	1/23/2021	421.00
	PCard JE	00006	989953	383751	1/23/2021	116.00
	PCard JE	00006	989953	383751	1/23/2021	116.00
	PCard JE	00006	989953	383751	1/23/2021	99.00
	PCard JE	00006	989953	383751	1/23/2021	501.00
	PCard JE	00006	989953	383751	1/23/2021	110.00
	PCard JE	00006	989953	383751	1/23/2021	101.00

**County of Adams**  
**Vendor Payment Report**

<u>9114</u>	<u>Fleet - Commerce City</u>	<u>Fund</u>	<u>Voucher</u>	<u>Batch No</u>	<u>GL Date</u>	<u>Amount</u>
					Account Total	<u>5,776.93</u>
					Department Total	<u><u>23,453.20</u></u>

**County of Adams**  
**Vendor Payment Report**

<u>9115</u>	<u>Fleet - Strasburg</u>	<u>Fund</u>	<u>Voucher</u>	<u>Batch No</u>	<u>GL Date</u>	<u>Amount</u>
	Equipment Rental					
	PCard JE	00006	989953	383751	1/23/2021	155.09
	PCard JE	00006	989953	383751	1/23/2021	11.24
	PCard JE	00006	989953	383751	1/23/2021	12.50
	PCard JE	00006	989953	383751	1/23/2021	155.09
	PCard JE	00006	989953	383751	1/23/2021	7.97
					Account Total	341.89
	Fuel, Gas & Oil					
	PCard JE	00006	989953	383751	1/23/2021	54.10
					Account Total	54.10
	Minor Equipment					
	PCard JE	00006	989953	383751	1/23/2021	1,264.64
	PCard JE	00006	989953	383751	1/23/2021	315.00
					Account Total	1,579.64
	Operating Supplies					
	PCard JE	00006	989953	383751	1/23/2021	175.66
	PCard JE	00006	989953	383751	1/23/2021	60.50
	PCard JE	00006	989953	383751	1/23/2021	20.20
	PCard JE	00006	989953	383751	1/23/2021	33.93
					Account Total	290.29
	Software and Licensing					
	PCard JE	00006	989953	383751	1/23/2021	800.00
					Account Total	800.00
	Uniforms & Cleaning					
	PCard JE	00006	989953	383751	1/23/2021	57.47
	PCard JE	00006	989953	383751	1/23/2021	32.00
	PCard JE	00006	989953	383751	1/23/2021	57.47
	PCard JE	00006	989953	383751	1/23/2021	57.47
	PCard JE	00006	989953	383751	1/23/2021	57.47
	PCard JE	00006	989953	383751	1/23/2021	57.47
					Account Total	319.35
	Vehicle Parts & Supplies					
	PCard JE	00006	989953	383751	1/23/2021	472.91
	PCard JE	00006	989953	383751	1/23/2021	13,012.09

**County of Adams**  
**Vendor Payment Report**

<u>9115</u>	<u>Fleet - Strasburg</u>	<u>Fund</u>	<u>Voucher</u>	<u>Batch No</u>	<u>GL Date</u>	<u>Amount</u>
	PCard JE	00006	989953	383751	1/23/2021	4,463.59
	PCard JE	00006	989953	383751	1/23/2021	347.19
	PCard JE	00006	989953	383751	1/23/2021	394.46
					Account Total	18,690.24
	Vehicle Repair & Maint					
	PCard JE	00006	989953	383751	1/23/2021	2,150.24
	PCard JE	00006	989953	383751	1/23/2021	155.00
	PCard JE	00006	989953	383751	1/23/2021	155.00
	PCard JE	00006	989953	383751	1/23/2021	150.00
	PCard JE	00006	989953	383751	1/23/2021	150.00
	PCard JE	00006	989953	383751	1/23/2021	188.00
	PCard JE	00006	989953	383751	1/23/2021	208.00
					Account Total	3,156.24
					Department Total	25,231.75

**County of Adams**  
**Vendor Payment Report**

<u>1076</u>	<u>FO - Adams County Svc Center</u>	<u>Fund</u>	<u>Voucher</u>	<u>Batch No</u>	<u>GL Date</u>	<u>Amount</u>
	Building Repair & Maint					
	AUTOMATED BUILDING SOLUTIONS I	00001	989958	383759	2/3/2021	8,875.00
	PCard JE	00001	989953	383751	1/23/2021	1,349.91
	PCard JE	00001	989953	383751	1/23/2021	1,558.75
					Account Total	11,783.66
	Buildings					
	THERMAL & MOISTURE PROTECTION	00001	989967	383761	2/3/2021	1,585.00
	TRANE US INC	00001	989959	383759	2/3/2021	889.20
					Account Total	2,474.20
	Maintenance Contracts					
	COLO DEPT OF LABOR & EMPLOYMEN	00001	989937	383692	2/2/2021	80.00
					Account Total	80.00
	Minor Equipment					
	PCard JE	00001	989953	383751	1/23/2021	39.91
	PCard JE	00001	989953	383751	1/23/2021	201.88
					Account Total	241.79
	Operating Supplies					
	HILLYARD - DENVER	00001	989963	383759	2/3/2021	172.84
	PCard JE	00001	989953	383751	1/23/2021	1,494.60
	PCard JE	00001	989953	383751	1/23/2021	40.59
	PCard JE	00001	989953	383751	1/23/2021	825.03
	PCard JE	00001	989953	383751	1/23/2021	1,192.30
	PCard JE	00001	989953	383751	1/23/2021	220.00
					Account Total	3,945.36
	Repair & Maint Supplies					
	PCard JE	00001	989953	383751	1/23/2021	149.88
	PCard JE	00001	989953	383751	1/23/2021	9.16
	PCard JE	00001	989953	383751	1/23/2021	15.45
	PCard JE	00001	989953	383751	1/23/2021	12.38
	PCard JE	00001	989953	383751	1/23/2021	65.69
	PCard JE	00001	989953	383751	1/23/2021	447.47
	PCard JE	00001	989953	383751	1/23/2021	34.51
	PCard JE	00001	989953	383751	1/23/2021	46.30
	PCard JE	00001	989953	383751	1/23/2021	29.04

**County of Adams**  
**Vendor Payment Report**

<u>1076</u>	<u>FO - Adams County Svc Center</u>	<u>Fund</u>	<u>Voucher</u>	<u>Batch No</u>	<u>GL Date</u>	<u>Amount</u>
	PCard JE	00001	989953	383751	1/23/2021	35.04
	PCard JE	00001	989953	383751	1/23/2021	12.96
	PCard JE	00001	989953	383751	1/23/2021	205.96
	PCard JE	00001	989953	383751	1/23/2021	265.46
	PCard JE	00001	989953	383751	1/23/2021	50.00
	PCard JE	00001	989953	383751	1/23/2021	193.20
	PCard JE	00001	989953	383751	1/23/2021	14.63
	PCard JE	00001	989953	383751	1/23/2021	2,346.00
	PCard JE	00001	989953	383751	1/23/2021	165.29
	PCard JE	00001	989953	383751	1/23/2021	751.25
	PCard JE	00001	989953	383751	1/23/2021	1,286.70
					Account Total	6,136.37
					Department Total	24,661.38

**County of Adams**  
**Vendor Payment Report**

<u>1091</u>	<u>FO - Administration</u>	<u>Fund</u>	<u>Voucher</u>	<u>Batch No</u>	<u>GL Date</u>	<u>Amount</u>
	Consultant Services					
	PCard JE	00001	989953	383751	1/23/2021	17.67
					Account Total	17.67
	Education & Training					
	PCard JE	00001	989953	383751	1/23/2021	100.00
	PCard JE	00001	989953	383751	1/23/2021	100.00
					Account Total	200.00
	Equipment Rental					
	PCard JE	00001	989953	383751	1/23/2021	187.18
	PCard JE	00001	989953	383751	1/23/2021	156.74
	PCard JE	00001	989953	383751	1/23/2021	156.74
	PCard JE	00001	989953	383751	1/23/2021	12.91
	PCard JE	00001	989953	383751	1/23/2021	2.38
	PCard JE	00001	989953	383751	1/23/2021	15.53
	PCard JE	00001	989953	383751	1/23/2021	3.91
	PCard JE	00001	989953	383751	1/23/2021	187.18
	PCard JE	00001	989953	383751	1/23/2021	156.74
	PCard JE	00001	989953	383751	1/23/2021	156.74
	PCard JE	00001	989953	383751	1/23/2021	47.47
	PCard JE	00001	989953	383751	1/23/2021	21.04
					Account Total	1,104.56
	Gas & Electricity					
	PCard JE	00001	989953	383751	1/23/2021	180.94-
	PCard JE	00001	989953	383751	1/23/2021	165.42-
					Account Total	346.36-
	Minor Equipment					
	PCard JE	00001	989953	383751	1/23/2021	319.92
	PCard JE	00001	989953	383751	1/23/2021	43.96
					Account Total	363.88
	Operating Supplies					
	PCard JE	00001	989953	383751	1/23/2021	192.70
	PCard JE	00001	989953	383751	1/23/2021	18.26
					Account Total	210.96
	Printing External					



**County of Adams**  
**Vendor Payment Report**

<u>1091</u>	<u>FO - Administration</u>	<u>Fund</u>	<u>Voucher</u>	<u>Batch No</u>	<u>GL Date</u>	<u>Amount</u>
	PCard JE	00001	989953	383751	1/23/2021	40.00
					Account Total	40.00
	Repair & Maint Supplies					
	PCard JE	00001	989953	383751	1/23/2021	10.00
					Account Total	10.00
	Special Events					
	PCard JE	00001	989953	383751	1/23/2021	72.00
					Account Total	72.00
	Subscrip/Publications					
	PCard JE	00001	989953	383751	1/23/2021	44.97
	PCard JE	00001	989953	383751	1/23/2021	14.99
					Account Total	59.96
					Department Total	<u>1,732.67</u>

**County of Adams**  
**Vendor Payment Report**

<u>5025</u>	<u>FO - Club House Maintenance</u>	<u>Fund</u>	<u>Voucher</u>	<u>Batch No</u>	<u>GL Date</u>	<u>Amount</u>
	Repair & Maint Supplies					
	PCard JE	00005	989953	383751	1/23/2021	645.25
	PCard JE	00005	989953	383751	1/23/2021	38.45
					Account Total	<u>683.70</u>
					Department Total	<u><u>683.70</u></u>

**County of Adams**  
**Vendor Payment Report**

<u>1060</u>	<u>FO - Community Corrections</u>	<u>Fund</u>	<u>Voucher</u>	<u>Batch No</u>	<u>GL Date</u>	<u>Amount</u>
	Building Repair & Maint					
	PCard JE	00001	989953	383751	1/23/2021	683.00
	PCard JE	00001	989953	383751	1/23/2021	320.00
					Account Total	1,003.00
	Repair & Maint Supplies					
	PCard JE	00001	989953	383751	1/23/2021	8.09
	PCard JE	00001	989953	383751	1/23/2021	33.42
	PCard JE	00001	989953	383751	1/23/2021	10.32
	PCard JE	00001	989953	383751	1/23/2021	3.92
	PCard JE	00001	989953	383751	1/23/2021	74.62
	PCard JE	00001	989953	383751	1/23/2021	16.17
	PCard JE	00001	989953	383751	1/23/2021	46.92
	PCard JE	00001	989953	383751	1/23/2021	268.89
	PCard JE	00001	989953	383751	1/23/2021	14.40
					Account Total	476.75
					Department Total	1,479.75

**County of Adams**  
**Vendor Payment Report**

<u>9251</u>	<u>FO - Conference Center</u>	<u>Fund</u>	<u>Voucher</u>	<u>Batch No</u>	<u>GL Date</u>	<u>Amount</u>
	Equipment Rental					
	PCard JE	00001	989953	383751	1/23/2021	155.09
	PCard JE	00001	989953	383751	1/23/2021	3.45
	PCard JE	00001	989953	383751	1/23/2021	155.09
					Account Total	<u>313.63</u>
					Department Total	<u><u>313.63</u></u>

**County of Adams**  
**Vendor Payment Report**

<u>1114</u>	<u>FO - District Attorney Bldg.</u>	<u>Fund</u>	<u>Voucher</u>	<u>Batch No</u>	<u>GL Date</u>	<u>Amount</u>
	Building Repair & Maint					
	PCard JE	00001	989953	383751	1/23/2021	198.00
	PCard JE	00001	989953	383751	1/23/2021	15.00
					Account Total	213.00
	Minor Equipment					
	PCard JE	00001	989953	383751	1/23/2021	35.96
					Account Total	35.96
	Operating Supplies					
	PCard JE	00001	989953	383751	1/23/2021	1,494.60
	PCard JE	00001	989953	383751	1/23/2021	138.54
	PCard JE	00001	989953	383751	1/23/2021	9.70
	PCard JE	00001	989953	383751	1/23/2021	19.95
					Account Total	1,662.79
	Repair & Maint Supplies					
	PCard JE	00001	989953	383751	1/23/2021	627.00
	PCard JE	00001	989953	383751	1/23/2021	19.09
	PCard JE	00001	989953	383751	1/23/2021	44.94
	PCard JE	00001	989953	383751	1/23/2021	228.68
	PCard JE	00001	989953	383751	1/23/2021	228.68
	PCard JE	00001	989953	383751	1/23/2021	469.18
	PCard JE	00001	989953	383751	1/23/2021	145.00
	PCard JE	00001	989953	383751	1/23/2021	54.48
	PCard JE	00001	989953	383751	1/23/2021	30.21
	PCard JE	00001	989953	383751	1/23/2021	36.92
	PCard JE	00001	989953	383751	1/23/2021	5.28
	PCard JE	00001	989953	383751	1/23/2021	400.00
					Account Total	2,289.46
					Department Total	4,201.21

**County of Adams**  
**Vendor Payment Report**

<u>2090</u>	<u>FO - Flatrock Facility</u>	<u>Fund</u>	<u>Voucher</u>	<u>Batch No</u>	<u>GL Date</u>	<u>Amount</u>
	Building Repair & Maint					
	PCard JE	00050	989953	383751	1/23/2021	1,284.75
					Account Total	1,284.75
	Operating Supplies					
	PCard JE	00050	989953	383751	1/23/2021	263.11
	PCard JE	00050	989953	383751	1/23/2021	54.85
					Account Total	317.96
	Repair & Maint Supplies					
	PCard JE	00050	989953	383751	1/23/2021	17.60
	PCard JE	00050	989953	383751	1/23/2021	87.15
	PCard JE	00050	989953	383751	1/23/2021	617.50
	PCard JE	00050	989953	383751	1/23/2021	492.00
	PCard JE	00050	989953	383751	1/23/2021	254.18
	PCard JE	00050	989953	383751	1/23/2021	42.50
	PCard JE	00050	989953	383751	1/23/2021	18.97
	PCard JE	00050	989953	383751	1/23/2021	21.25
					Account Total	1,551.15
					Department Total	3,153.86

**County of Adams**  
**Vendor Payment Report**

<u>1077</u>	<u>FO - Government Center</u>	<u>Fund</u>	<u>Voucher</u>	<u>Batch No</u>	<u>GL Date</u>	<u>Amount</u>
	Building Repair & Maint					
	PCard JE	00001	989953	383751	1/23/2021	1,715.00
	PCard JE	00001	989953	383751	1/23/2021	2,120.00
	PCard JE	00001	989953	383751	1/23/2021	675.00
					Account Total	4,510.00
	Grounds Maintenance					
	PCard JE	00001	989953	383751	1/23/2021	1,860.00
					Account Total	1,860.00
	Minor Equipment					
	PCard JE	00001	989953	383751	1/23/2021	44.99
	PCard JE	00001	989953	383751	1/23/2021	203.68
					Account Total	248.67
	Operating Supplies					
	PCard JE	00001	989953	383751	1/23/2021	2,989.20
	PCard JE	00001	989953	383751	1/23/2021	240.36
	PCard JE	00001	989953	383751	1/23/2021	1,154.20
					Account Total	4,383.76
	Repair & Maint Supplies					
	PCard JE	00001	989953	383751	1/23/2021	303.45
	PCard JE	00001	989953	383751	1/23/2021	617.50
	PCard JE	00001	989953	383751	1/23/2021	40.95
	PCard JE	00001	989953	383751	1/23/2021	322.99
	PCard JE	00001	989953	383751	1/23/2021	103.63
	PCard JE	00001	989953	383751	1/23/2021	12.99
	PCard JE	00001	989953	383751	1/23/2021	25.12
	PCard JE	00001	989953	383751	1/23/2021	628.10
	PCard JE	00001	989953	383751	1/23/2021	5.07
	PCard JE	00001	989953	383751	1/23/2021	231.56
	PCard JE	00001	989953	383751	1/23/2021	273.89
	PCard JE	00001	989953	383751	1/23/2021	45.30
	PCard JE	00001	989953	383751	1/23/2021	186.49
	PCard JE	00001	989953	383751	1/23/2021	42.46
	PCard JE	00001	989953	383751	1/23/2021	253.58
	PCard JE	00001	989953	383751	1/23/2021	357.40

**County of Adams**  
**Vendor Payment Report**

<u>1077</u>	<u>FO - Government Center</u>	<u>Fund</u>	<u>Voucher</u>	<u>Batch No</u>	<u>GL Date</u>	<u>Amount</u>
	PCard JE	00001	989953	383751	1/23/2021	253.58-
	PCard JE	00001	989953	383751	1/23/2021	25.31
	PCard JE	00001	989953	383751	1/23/2021	277.21
	PCard JE	00001	989953	383751	1/23/2021	43.51
	PCard JE	00001	989953	383751	1/23/2021	79.61
	PCard JE	00001	989953	383751	1/23/2021	171.79
	PCard JE	00001	989953	383751	1/23/2021	22.18
	PCard JE	00001	989953	383751	1/23/2021	100.00
	PCard JE	00001	989953	383751	1/23/2021	30.88
	PCard JE	00001	989953	383751	1/23/2021	79.86
					Account Total	4,027.25
					Department Total	15,029.68



**County of Adams**  
**Vendor Payment Report**

<u>1070</u>	<u>FO - Honnen/Plan&amp;Devel/MV Ware</u>	<u>Fund</u>	<u>Voucher</u>	<u>Batch No</u>	<u>GL Date</u>	<u>Amount</u>
	Building Repair & Maint					
	PCard JE	00001	989953	383751	1/23/2021	1,097.00
	PCard JE	00001	989953	383751	1/23/2021	876.00
					Account Total	1,973.00
	Maintenance Contracts					
	COLO DEPT OF LABOR & EMPLOYMEN	00001	989936	383689	2/2/2021	40.00
					Account Total	40.00
	Minor Equipment					
	PCard JE	00001	989953	383751	1/23/2021	17.99
					Account Total	17.99
	Operating Supplies					
	PCard JE	00001	989953	383751	1/23/2021	561.10
	PCard JE	00001	989953	383751	1/23/2021	511.60
					Account Total	1,072.70
	Repair & Maint Supplies					
	PCard JE	00001	989953	383751	1/23/2021	18.85
	PCard JE	00001	989953	383751	1/23/2021	319.92
	PCard JE	00001	989953	383751	1/23/2021	40.42
					Account Total	379.19
					Department Total	3,482.88

**County of Adams**  
**Vendor Payment Report**

<u>1079</u>	<u>FO - Human Services Center</u>	<u>Fund</u>	<u>Voucher</u>	<u>Batch No</u>	<u>GL Date</u>	<u>Amount</u>
	Building Repair & Maint					
	PCard JE	00001	989953	383751	1/23/2021	193.00
	PCard JE	00001	989953	383751	1/23/2021	500.00
					Account Total	693.00
	Maintenance Contracts					
	PCard JE	00001	989953	383751	1/23/2021	480.00
					Account Total	480.00
	Minor Equipment					
	PCard JE	00001	989953	383751	1/23/2021	2,017.82
	PCard JE	00001	989953	383751	1/23/2021	152.21
	PCard JE	00001	989953	383751	1/23/2021	237.60
	PCard JE	00001	989953	383751	1/23/2021	59.85
	PCard JE	00001	989953	383751	1/23/2021	3.97
	PCard JE	00001	989953	383751	1/23/2021	34.85
					Account Total	2,506.30
	Operating Supplies					
	PCard JE	00001	989953	383751	1/23/2021	939.12
	PCard JE	00001	989953	383751	1/23/2021	705.60
					Account Total	1,644.72
	Other Communications					
	T MOBILE	00001	989968	383761	2/3/2021	30.56
					Account Total	30.56
	Other Repair & Maint					
	PARK 12 HUNDRED OWNERS ASSOCIA	00001	989957	383759	2/3/2021	16,562.00
	PARK 12 HUNDRED OWNERS ASSOCIA	00001	989964	383761	2/3/2021	16,149.88
	PARK 12 HUNDRED OWNERS ASSOCIA	00001	989965	383761	2/3/2021	16,149.88
					Account Total	48,861.76
	Repair & Maint Supplies					
	PCard JE	00001	989953	383751	1/23/2021	1,587.32
	PCard JE	00001	989953	383751	1/23/2021	26.00
	PCard JE	00001	989953	383751	1/23/2021	10.66
	PCard JE	00001	989953	383751	1/23/2021	38.88
	PCard JE	00001	989953	383751	1/23/2021	72.00
	PCard JE	00001	989953	383751	1/23/2021	1,490.04

**County of Adams**  
**Vendor Payment Report**

<u>1079</u>	<u>FO - Human Services Center</u>	<u>Fund</u>	<u>Voucher</u>	<u>Batch No</u>	<u>GL Date</u>	<u>Amount</u>
	PCard JE	00001	989953	383751	1/23/2021	7.42
	PCard JE	00001	989953	383751	1/23/2021	82.74
	PCard JE	00001	989953	383751	1/23/2021	49.98
	PCard JE	00001	989953	383751	1/23/2021	6.47
	PCard JE	00001	989953	383751	1/23/2021	61.12
	PCard JE	00001	989953	383751	1/23/2021	6.98
	PCard JE	00001	989953	383751	1/23/2021	161.03
	PCard JE	00001	989953	383751	1/23/2021	642.63
	PCard JE	00001	989953	383751	1/23/2021	642.63-
	PCard JE	00001	989953	383751	1/23/2021	54.00
					Account Total	3,654.64
					Department Total	57,870.98

**County of Adams**  
**Vendor Payment Report**

<u>1071</u>	<u>FO - Justice Center</u>	<u>Fund</u>	<u>Voucher</u>	<u>Batch No</u>	<u>GL Date</u>	<u>Amount</u>
	Building Repair & Maint					
	PCard JE	00001	989953	383751	1/23/2021	143.18-
	PCard JE	00001	989953	383751	1/23/2021	402.00
					Account Total	258.82
	Maintenance Contracts					
	PCard JE	00001	989953	383751	1/23/2021	217.50
	PCard JE	00001	989953	383751	1/23/2021	410.00
					Account Total	627.50
	Operating Supplies					
	PCard JE	00001	989953	383751	1/23/2021	113.04
	PCard JE	00001	989953	383751	1/23/2021	550.90
	PCard JE	00001	989953	383751	1/23/2021	1,515.80
					Account Total	2,179.74
	Repair & Maint Supplies					
	PCard JE	00001	989953	383751	1/23/2021	92.88
	PCard JE	00001	989953	383751	1/23/2021	98.64
	PCard JE	00001	989953	383751	1/23/2021	110.85
	PCard JE	00001	989953	383751	1/23/2021	45.55
	PCard JE	00001	989953	383751	1/23/2021	13.44
	PCard JE	00001	989953	383751	1/23/2021	573.20
	PCard JE	00001	989953	383751	1/23/2021	9.48
	PCard JE	00001	989953	383751	1/23/2021	23.29
	PCard JE	00001	989953	383751	1/23/2021	128.00
	PCard JE	00001	989953	383751	1/23/2021	59.00
	PCard JE	00001	989953	383751	1/23/2021	96.31
	PCard JE	00001	989953	383751	1/23/2021	49.20
	PCard JE	00001	989953	383751	1/23/2021	11.98
	PCard JE	00001	989953	383751	1/23/2021	228.68-
	PCard JE	00001	989953	383751	1/23/2021	5.40
	PCard JE	00001	989953	383751	1/23/2021	720.00
	PCard JE	00001	989953	383751	1/23/2021	25.94
	PCard JE	00001	989953	383751	1/23/2021	1,003.59-
	PCard JE	00001	989953	383751	1/23/2021	195.88
	PCard JE	00001	989953	383751	1/23/2021	195.88-
	PCard JE	00001	989953	383751	1/23/2021	180.15

**County of Adams**  
**Vendor Payment Report**

<u>1071</u>	<u>FO - Justice Center</u>	<u>Fund</u>	<u>Voucher</u>	<u>Batch No</u>	<u>GL Date</u>	<u>Amount</u>
	PCard JE	00001	989953	383751	1/23/2021	67.81
	PCard JE	00001	989953	383751	1/23/2021	120.30
	PCard JE	00001	989953	383751	1/23/2021	23.53-
	PCard JE	00001	989953	383751	1/23/2021	175.95
	PCard JE	00001	989953	383751	1/23/2021	15.85
	PCard JE	00001	989953	383751	1/23/2021	882.00
	PCard JE	00001	989953	383751	1/23/2021	882.00
	PCard JE	00001	989953	383751	1/23/2021	21.82
	PCard JE	00001	989953	383751	1/23/2021	81.49
	PCard JE	00001	989953	383751	1/23/2021	225.01
					Account Total	3,459.74
					Department Total	6,525.80

**County of Adams**  
**Vendor Payment Report**

<u>1019</u>	<u>FO - Mailroom &amp; Dock</u>	<u>Fund</u>	<u>Voucher</u>	<u>Batch No</u>	<u>GL Date</u>	<u>Amount</u>
	Equipment Rental					
	PCard JE	00001	989953	383751	1/23/2021	155.09
	PCard JE	00001	989953	383751	1/23/2021	3.78
	PCard JE	00001	989953	383751	1/23/2021	1.27
	PCard JE	00001	989953	383751	1/23/2021	155.09
	PCard JE	00001	989953	383751	1/23/2021	6.90
	PCard JE	00001	989953	383751	1/23/2021	2,419.23
	PCard JE	00001	989953	383751	1/23/2021	273.48
					Account Total	3,014.84
	Operating Supplies					
	PCard JE	00001	989953	383751	1/23/2021	1,478.94
	PCard JE	00001	989953	383751	1/23/2021	336.55
					Account Total	1,815.49
					Department Total	4,830.33

**County of Adams**  
**Vendor Payment Report**

<u>1069</u>	<u>FO - Old Animal Shelter</u>	<u>Fund</u>	<u>Voucher</u>	<u>Batch No</u>	<u>GL Date</u>	<u>Amount</u>
	Repair & Maint Supplies					
	PCard JE	00001	989953	383751	1/23/2021	8.74
					Account Total	8.74
					Department Total	8.74

**County of Adams**  
**Vendor Payment Report**

<u>1062</u>	<u>FO - Other Facilities</u>	<u>Fund</u>	<u>Voucher</u>	<u>Batch No</u>	<u>GL Date</u>	<u>Amount</u>
	Building Rental					
	ROSTIE SANDRA	00001	989947	383687	2/3/2021	2,600.00
					Account Total	<u>2,600.00</u>
	Operating Supplies					
	PCard JE	00001	989953	383751	1/23/2021	432.70
					Account Total	<u>432.70</u>
					Department Total	<u><u>3,032.70</u></u>



**County of Adams**  
**Vendor Payment Report**

<u>1111</u>	<u>FO - Parks Facilities</u>	<u>Fund</u>	<u>Voucher</u>	<u>Batch No</u>	<u>GL Date</u>	<u>Amount</u>
	Building Repair & Maint					
	PCard JE	00001	989953	383751	1/23/2021	172.50
	PCard JE	00001	989953	383751	1/23/2021	227.50
	PCard JE	00001	989953	383751	1/23/2021	395.00
					Account Total	795.00
	Minor Equipment					
	PCard JE	00001	989953	383751	1/23/2021	58.84
	PCard JE	00001	989953	383751	1/23/2021	158.73
					Account Total	217.57
	Repair & Maint Supplies					
	PCard JE	00001	989953	383751	1/23/2021	226.77
	PCard JE	00001	989953	383751	1/23/2021	865.00
	PCard JE	00001	989953	383751	1/23/2021	50.68
	PCard JE	00001	989953	383751	1/23/2021	117.80
	PCard JE	00001	989953	383751	1/23/2021	246.41
	PCard JE	00001	989953	383751	1/23/2021	80.98
	PCard JE	00001	989953	383751	1/23/2021	48.18
	PCard JE	00001	989953	383751	1/23/2021	202.79
	PCard JE	00001	989953	383751	1/23/2021	969.88
	PCard JE	00001	989953	383751	1/23/2021	77.54
	PCard JE	00001	989953	383751	1/23/2021	368.69
	PCard JE	00001	989953	383751	1/23/2021	497.95
					Account Total	3,752.67
					Department Total	4,765.24

**County of Adams**  
**Vendor Payment Report**

<u>1123</u>	<u>FO - Riverdale Animal Shelter</u>	<u>Fund</u>	<u>Voucher</u>	<u>Batch No</u>	<u>GL Date</u>	<u>Amount</u>
	Operating Supplies					
	PCard JE	00001	989953	383751	1/23/2021	<u>552.96</u>
					Account Total	<u>552.96</u>
					Department Total	<u><u>552.96</u></u>

**County of Adams**  
**Vendor Payment Report**

<u>1112</u>	<u>FO - Sheriff HQ/Coroner Bldg</u>	<u>Fund</u>	<u>Voucher</u>	<u>Batch No</u>	<u>GL Date</u>	<u>Amount</u>
	Building Repair & Maint					
	ADT COMMERCIAL LLC	00001	989962	383759	2/3/2021	564.08
					Account Total	564.08
	Maintenance Contracts					
	PCard JE	00001	989953	383751	1/23/2021	104.00
					Account Total	104.00
	Operating Supplies					
	PCard JE	00001	989953	383751	1/23/2021	26.75
					Account Total	26.75
	Repair & Maint Supplies					
	PCard JE	00001	989953	383751	1/23/2021	180.00
					Account Total	180.00
					Department Total	874.83

**County of Adams**  
**Vendor Payment Report**

<u>2009</u>	<u>FO - Sheriff Maintenance</u>	<u>Fund</u>	<u>Voucher</u>	<u>Batch No</u>	<u>GL Date</u>	<u>Amount</u>
	Building Repair & Maint					
	ADT COMMERCIAL LLC	00001	989961	383759	2/3/2021	277.50
	PCard JE	00001	989953	383751	1/23/2021	120.00
	PCard JE	00001	989953	383751	1/23/2021	675.00
					Account Total	1,072.50
	Grounds Maintenance					
	PCard JE	00001	989953	383751	1/23/2021	294.10
					Account Total	294.10
	Maintenance Contracts					
	LIQUID ENVIRO SOLUTIONS OF TEX	00001	989960	383759	2/3/2021	1,063.72
	PCard JE	00001	989953	383751	1/23/2021	1,063.72
	PCard JE	00001	989953	383751	1/23/2021	2,055.00
					Account Total	4,182.44
	Minor Equipment					
	PCard JE	00001	989953	383751	1/23/2021	25.76
	PCard JE	00001	989953	383751	1/23/2021	10.54
					Account Total	36.30
	Repair & Maint Supplies					
	PCard JE	00001	989953	383751	1/23/2021	15.17
	PCard JE	00001	989953	383751	1/23/2021	155.67
	PCard JE	00001	989953	383751	1/23/2021	798.38
	PCard JE	00001	989953	383751	1/23/2021	289.26
	PCard JE	00001	989953	383751	1/23/2021	321.53
	PCard JE	00001	989953	383751	1/23/2021	232.64
	PCard JE	00001	989953	383751	1/23/2021	484.01
	PCard JE	00001	989953	383751	1/23/2021	46.79
	PCard JE	00001	989953	383751	1/23/2021	66.50
	PCard JE	00001	989953	383751	1/23/2021	190.08
	PCard JE	00001	989953	383751	1/23/2021	78.40
	PCard JE	00001	989953	383751	1/23/2021	234.38
	PCard JE	00001	989953	383751	1/23/2021	1,600.48
	PCard JE	00001	989953	383751	1/23/2021	23.45
	PCard JE	00001	989953	383751	1/23/2021	35.98
	PCard JE	00001	989953	383751	1/23/2021	100.81

**County of Adams**  
**Vendor Payment Report**

<u>2009</u>	<u>FO - Sheriff Maintenance</u>	<u>Fund</u>	<u>Voucher</u>	<u>Batch No</u>	<u>GL Date</u>	<u>Amount</u>
	PCard JE	00001	989953	383751	1/23/2021	197.98
	PCard JE	00001	989953	383751	1/23/2021	1,957.50
	PCard JE	00001	989953	383751	1/23/2021	77.29
	PCard JE	00001	989953	383751	1/23/2021	59.84
	PCard JE	00001	989953	383751	1/23/2021	190.08
	PCard JE	00001	989953	383751	1/23/2021	960.15
	PCard JE	00001	989953	383751	1/23/2021	595.23
					Account Total	<u>8,711.60</u>
					Department Total	<u><u>14,296.94</u></u>

**County of Adams**  
**Vendor Payment Report**

<u>1072</u>	<u>FO - West Services Center</u>	<u>Fund</u>	<u>Voucher</u>	<u>Batch No</u>	<u>GL Date</u>	<u>Amount</u>
	Building Repair & Maint					
	PCard JE	00001	989953	383751	1/23/2021	478.59-
	PCard JE	00001	989953	383751	1/23/2021	478.59
	PCard JE	00001	989953	383751	1/23/2021	476.18
					Account Total	476.18
	Buildings					
	THERMAL & MOISTURE PROTECTION	00001	989966	383761	2/3/2021	1,080.00
					Account Total	1,080.00
	Maintenance Contracts					
	COLO DEPT OF LABOR & EMPLOYME	00001	989940	383693	2/2/2021	60.00
					Account Total	60.00
	Minor Equipment					
	PCard JE	00001	989953	383751	1/23/2021	110.16
					Account Total	110.16
	Operating Supplies					
	PCard JE	00001	989953	383751	1/23/2021	80.12
	PCard JE	00001	989953	383751	1/23/2021	418.15
	PCard JE	00001	989953	383751	1/23/2021	714.40
					Account Total	1,212.67
	Repair & Maint Supplies					
	PCard JE	00001	989953	383751	1/23/2021	81.80
	PCard JE	00001	989953	383751	1/23/2021	113.55
	PCard JE	00001	989953	383751	1/23/2021	133.20
	PCard JE	00001	989953	383751	1/23/2021	49.43
	PCard JE	00001	989953	383751	1/23/2021	25.23
	PCard JE	00001	989953	383751	1/23/2021	10.00
	PCard JE	00001	989953	383751	1/23/2021	43.97
	PCard JE	00001	989953	383751	1/23/2021	69.74
	PCard JE	00001	989953	383751	1/23/2021	466.73
					Account Total	993.65
					Department Total	3,932.66

**County of Adams**  
**Vendor Payment Report**

<u>600039004010</u>	<u>Fraud Invest and Recovery Dir</u>	<u>Fund</u>	<u>Voucher</u>	<u>Batch No</u>	<u>GL Date</u>	<u>Amount</u>
	Equipment Rental					
	PCard JE	00015	989953	383751	1/23/2021	184.21
	PCard JE	00015	989953	383751	1/23/2021	38.44
	PCard JE	00015	989953	383751	1/23/2021	22.50
					Account Total	245.15
	Operating Supplies					
	PCard JE	00015	989953	383751	1/23/2021	21.95
					Account Total	21.95
					Department Total	267.10

**County of Adams**  
**Vendor Payment Report**

<u>3098</u>	<u>General Capital Improvements</u>	<u>Fund</u>	<u>Voucher</u>	<u>Batch No</u>	<u>GL Date</u>	<u>Amount</u>
	Buildings					
	PCard JE	00004	989953	383751	1/23/2021	1,216.80
	PCard JE	00004	989953	383751	1/23/2021	273.30
					Account Total	<u>1,490.10</u>
					Department Total	<u><u>1,490.10</u></u>



**County of Adams**  
**Vendor Payment Report**

<u>1</u>	<u>General Fund</u>	<u>Fund</u>	<u>Voucher</u>	<u>Batch No</u>	<u>GL Date</u>	<u>Amount</u>
	Collateral Deposits Payable					
	FENICE PARTNERS LLC	00001	989906	383675	2/2/2021	21,005.80
					Account Total	21,005.80
	Received not Vouchered Clrg					
	ACCELA INC	00001	990088	383909	2/4/2021	13,194.00
	ACCELA INC	00001	990088	383909	2/4/2021	1,633.21
	ANM	00001	990051	383900	2/4/2021	109,150.00
	BRYAN LAURA CHRISTINE	00001	990108	384040	2/5/2021	250.00
	BRYAN LAURA CHRISTINE	00001	990108	384040	2/5/2021	125.00
	CA SHORT COMPANY	00001	990080	383909	2/4/2021	30,000.00
	CA SHORT COMPANY	00001	990081	383909	2/4/2021	4,815.00
	CA SHORT COMPANY	00001	990082	383909	2/4/2021	808.96
	CA SHORT COMPANY	00001	990083	383909	2/4/2021	36.93
	CA SHORT COMPANY	00001	990084	383909	2/4/2021	313.70
	DLT SOLUTIONS LLC	00001	990087	383909	2/4/2021	280.84
	DOUGLASS COLONY GROUP INC	00001	990046	383900	2/4/2021	4,795.00
	DOUGLASS COLONY GROUP INC	00001	990030	383900	2/4/2021	320,287.00
	DOUGLASS COLONY GROUP INC	00001	990046	383900	2/4/2021	103,985.00
	G4S SECURE SOLUTIONS USA INC	00001	989993	383784	2/3/2021	6,473.20
	G4S SECURE SOLUTIONS USA INC	00001	990104	384040	2/5/2021	5,368.16
	G4S SECURE SOLUTIONS USA INC	00001	990105	384040	2/5/2021	5,372.78
	G4S SECURE SOLUTIONS USA INC	00001	990106	384040	2/5/2021	5,452.34
	G4S SECURE SOLUTIONS USA INC	00001	990107	384040	2/5/2021	5,413.80
	HRQ INC	00001	990045	383900	2/4/2021	78.85
	INSIGHT PUBLIC SECTOR	00001	990089	383909	2/4/2021	45,287.92
	LAPLINK SOFTWARE INC	00001	990085	383909	2/4/2021	7,650.00
	MOBILE STORAGE SOLUTIONS	00001	990040	383900	2/4/2021	1,345.00
	MOBILE STORAGE SOLUTIONS	00001	990041	383900	2/4/2021	535.00
	MOBILE STORAGE SOLUTIONS	00001	990042	383900	2/4/2021	100.00
	MOBILE STORAGE SOLUTIONS	00001	990043	383900	2/4/2021	5,995.00
	MOBILE STORAGE SOLUTIONS	00001	990044	383900	2/4/2021	131.67
	NAVAL SURFACE WARFARE CENTER C	00001	990071	383900	2/4/2021	7,500.00
	ONENECK IT SOLUTIONS LLC	00001	990086	383909	2/4/2021	10,464.18
	PHILLIPS PET FOOD & SUPPLIES	00001	990052	383900	2/4/2021	649.45
	PRO FORCE LAW ENFORCEMENT	00001	990072	383900	2/4/2021	3,632.00

**County of Adams**  
**Vendor Payment Report**

<u>1</u>	<u>General Fund</u>	<u>Fund</u>	<u>Voucher</u>	<u>Batch No</u>	<u>GL Date</u>	<u>Amount</u>
	PRO FORCE LAW ENFORCEMENT	00001	990073	383900	2/4/2021	560.00
	ROADRUNNER PHARMACY INCORPORAT	00001	990053	383900	2/4/2021	773.72
	SIEGEL THOMAS WEIL	00001	989995	383784	2/3/2021	250.00
	SUMMIT FOOD SERVICE LLC	00001	990076	383900	2/4/2021	24,358.64
	T&G PECOS LLC	00001	990075	383900	2/4/2021	1,800.00
	T&G PECOS LLC	00001	990090	383900	2/4/2021	1,800.00
	TRANE US INC	00001	990032	383900	2/4/2021	26,260.00
	TRANE US INC	00001	990029	383900	2/4/2021	4,999.99
	WRIGHT WATER ENGINEERS	00001	990024	383900	2/4/2021	1,675.62
	WRIGHT WATER ENGINEERS	00001	990025	383900	2/4/2021	985.00
					Account Total	<u>764,586.96</u>
	Retainages Payable					
	DOUGLASS COLONY GROUP INC	00001	990030	383900	2/4/2021	16,014.35-
	DOUGLASS COLONY GROUP INC	00001	990046	383900	2/4/2021	5,199.25-
	DOUGLASS COLONY GROUP INC	00001	990046	383900	2/4/2021	239.75-
					Account Total	<u>21,453.35-</u>
					Department Total	<u><u>764,139.41</u></u>

**County of Adams**  
**Vendor Payment Report**

<u>9252</u>	<u>GF- Admin/Org Support</u>	<u>Fund</u>	<u>Voucher</u>	<u>Batch No</u>	<u>GL Date</u>	<u>Amount</u>
	Membership Dues					
	PCard JE	00001	989953	383751	1/23/2021	3,000.00
	SMART COMMUTE METRO NORTH	00001	989885	383668	2/2/2021	20,787.50
					Account Total	23,787.50
	Other Professional Serv					
	COHEN MILSTEIN SELLERS & TOLL	00001	989656	383353	1/28/2021	472.50
					Account Total	472.50
					Department Total	24,260.00

**County of Adams**  
**Vendor Payment Report**

<u>5027</u>	<u>Golf Course- CIP</u>	<u>Fund</u>	<u>Voucher</u>	<u>Batch No</u>	<u>GL Date</u>	<u>Amount</u>
	Land Improvements					
	MODERN GOLF & TURF LLC	00005	989881	383667	2/2/2021	<u>60,835.00</u>
					Account Total	<u>60,835.00</u>
					Department Total	<u><u>60,835.00</u></u>

**County of Adams**  
**Vendor Payment Report**

<u>5</u>	<u>Golf Course Enterprise Fund</u>	<u>Fund</u>	<u>Voucher</u>	<u>Batch No</u>	<u>GL Date</u>	<u>Amount</u>
	Received not Vouchered Clrg					
	PROFESSIONAL RECREATION MGMT I	00005	989994	383784	2/3/2021	9,000.00
					Account Total	9,000.00
	Vendor Fee Sales Tax - State					
	PROFESSIONAL RECREATION MGMT I	00005	989938	383691	2/2/2021	252.60
					Account Total	252.60
					Department Total	9,252.60

**County of Adams**  
**Vendor Payment Report**

<u>5026</u>	<u>Golf Course- Maintenance</u>	<u>Fund</u>	<u>Voucher</u>	<u>Batch No</u>	<u>GL Date</u>	<u>Amount</u>
	Equipment Rental					
	BUCKEYE WELDING SUPPLY CO INC	00005	989879	383667	2/2/2021	30.60
					Account Total	30.60
	Fuel, Gas & Oil					
	AGFINITY INC	00005	989874	383667	2/2/2021	473.20
	AGFINITY INC	00005	989875	383667	2/2/2021	366.28
					Account Total	839.48
	Grounds Maintenance					
	COLO POWDER COATING	00005	989880	383667	2/2/2021	630.00
	PCard JE	00005	989953	383751	1/23/2021	65.25
	TORO NSN	00005	989883	383667	2/2/2021	233.00
					Account Total	928.25
	Repair & Maint Supplies					
	ALSCO AMERICAN INDUSTRIAL	00005	989876	383667	2/2/2021	56.13
	ALSCO AMERICAN INDUSTRIAL	00005	989877	383667	2/2/2021	56.13
	ALSCO AMERICAN INDUSTRIAL	00005	989878	383667	2/2/2021	56.13
	PCard JE	00005	989953	383751	1/23/2021	107.76
	PCard JE	00005	989953	383751	1/23/2021	59.33
	PCard JE	00005	989953	383751	1/23/2021	16.99
	PCard JE	00005	989953	383751	1/23/2021	34.98
					Account Total	387.45
	Vehicle Parts & Supplies					
	PCard JE	00005	989953	383751	1/23/2021	31.98
	PCard JE	00005	989953	383751	1/23/2021	31.36
	PCard JE	00005	989953	383751	1/23/2021	39.99
	PCard JE	00005	989953	383751	1/23/2021	21.00
	PCard JE	00005	989953	383751	1/23/2021	180.00
	PCard JE	00005	989953	383751	1/23/2021	55.50
	PCard JE	00005	989953	383751	1/23/2021	199.60
	PCard JE	00005	989953	383751	1/23/2021	371.54
	PCard JE	00005	989953	383751	1/23/2021	24.49
	PCard JE	00005	989953	383751	1/23/2021	26.53
	PCard JE	00005	989953	383751	1/23/2021	29.87
	PCard JE	00005	989953	383751	1/23/2021	163.81

**County of Adams**  
**Vendor Payment Report**

<u>5026</u>	<u>Golf Course- Maintenance</u>	<u>Fund</u>	<u>Voucher</u>	<u>Batch No</u>	<u>GL Date</u>	<u>Amount</u>
	PCard JE	00005	989953	383751	1/23/2021	19.90
	POTESTIO BROTHER EQUIPMENT	00005	989882	383667	2/2/2021	483.08
	PROFESSIONAL RECREATION MGMT I	00005	989938	383691	2/2/2021	188.00
					Account Total	1,866.65
					Department Total	4,052.43

**County of Adams**  
**Vendor Payment Report**

<u>5021</u>	<u>Golf Course- Pro Shop</u>	<u>Fund</u>	<u>Voucher</u>	<u>Batch No</u>	<u>GL Date</u>	<u>Amount</u>
	Golf Carts					
	PCard JE	00005	989953	383751	1/23/2021	67.89
					Account Total	67.89
	Golf Merchandise					
	PROFESSIONAL RECREATION MGMT I	00005	989938	383691	2/2/2021	638.00
	PROFESSIONAL RECREATION MGMT I	00005	989938	383691	2/2/2021	153.72
					Account Total	791.72
	Janitorial Services					
	PROFESSIONAL RECREATION MGMT I	00005	989938	383691	2/2/2021	1,104.45
					Account Total	1,104.45
	Operating Supplies					
	PCard JE	00005	989953	383751	1/23/2021	52.45
	PCard JE	00005	989953	383751	1/23/2021	5.98
					Account Total	58.43
	Other Professional Serv					
	PROFESSIONAL RECREATION MGMT I	00005	989938	383691	2/2/2021	346.29
	PROFESSIONAL RECREATION MGMT I	00005	989938	383691	2/2/2021	346.29
					Account Total	692.58
	Postage & Freight					
	PCard JE	00005	989953	383751	1/23/2021	93.40
					Account Total	93.40
	Repair & Maint Supplies					
	PROFESSIONAL RECREATION MGMT I	00005	989938	383691	2/2/2021	8.00
					Account Total	8.00
	Security Service					
	PROFESSIONAL RECREATION MGMT I	00005	989938	383691	2/2/2021	647.50
					Account Total	647.50
	Telephone					
	PCard JE	00005	989953	383751	1/23/2021	60.48
	PROFESSIONAL RECREATION MGMT I	00005	989938	383691	2/2/2021	576.97
					Account Total	637.45
					Department Total	4,101.42



**County of Adams**  
**Vendor Payment Report**

<u>98600</u>	<u>Governor's Summer Job Hunt</u>	<u>Fund</u>	<u>Voucher</u>	<u>Batch No</u>	<u>GL Date</u>	<u>Amount</u>
	Printing External					
	PCard JE	00035	989953	383751	1/23/2021	<u>2,483.02</u>
					Account Total	<u>2,483.02</u>
					Department Total	<u><u>2,483.02</u></u>

**County of Adams**  
**Vendor Payment Report**

<u>31</u>	<u>Head Start Fund</u>	<u>Fund</u>	<u>Voucher</u>	<u>Batch No</u>	<u>GL Date</u>	<u>Amount</u>
	Received not Vouchered Clrg					
	CESCO LINGUISTIC SERVICE INC	00031	990035	383900	2/4/2021	95.09
	GENESIS FLOOR CARE OF COLORADO	00031	990048	383900	2/4/2021	2,322.00
	MIGHTY LITTLE VOICES SPEECH TH	00031	990049	383900	2/4/2021	2,080.00
					Account Total	<u>4,497.09</u>
					Department Total	<u><u>4,497.09</u></u>

**County of Adams**  
**Vendor Payment Report**

<u>935121</u>	<u>HHS Grant</u>	<u>Fund</u>	<u>Voucher</u>	<u>Batch No</u>	<u>GL Date</u>	<u>Amount</u>
	Equipment Rental					
	PCard JE	00031	989953	383751	1/23/2021	281.64
	PCard JE	00031	989953	383751	1/23/2021	173.80
	PCard JE	00031	989953	383751	1/23/2021	184.21
	PCard JE	00031	989953	383751	1/23/2021	156.74
	PCard JE	00031	989953	383751	1/23/2021	156.74
	PCard JE	00031	989953	383751	1/23/2021	156.74
	PCard JE	00031	989953	383751	1/23/2021	156.74
	PCard JE	00031	989953	383751	1/23/2021	124.62
	PCard JE	00031	989953	383751	1/23/2021	130.60
	PCard JE	00031	989953	383751	1/23/2021	60.13
	PCard JE	00031	989953	383751	1/23/2021	75.55
	PCard JE	00031	989953	383751	1/23/2021	54.35
	PCard JE	00031	989953	383751	1/23/2021	138.99
	PCard JE	00031	989953	383751	1/23/2021	24.23
	PCard JE	00031	989953	383751	1/23/2021	81.90
	PCard JE	00031	989953	383751	1/23/2021	73.56
	PCard JE	00031	989953	383751	1/23/2021	1.36
	PCard JE	00031	989953	383751	1/23/2021	.49
	PCard JE	00031	989953	383751	1/23/2021	6.91
	PCard JE	00031	989953	383751	1/23/2021	83.14
	PCard JE	00031	989953	383751	1/23/2021	31.21
	PCard JE	00031	989953	383751	1/23/2021	134.82
	PCard JE	00031	989953	383751	1/23/2021	22.41
	PCard JE	00031	989953	383751	1/23/2021	101.34
	PCard JE	00031	989953	383751	1/23/2021	84.15
	PCard JE	00031	989953	383751	1/23/2021	.23
	PCard JE	00031	989953	383751	1/23/2021	.35
					Account Total	2,496.95
	Health & Safety Materials					
	PCard JE	00031	989953	383751	1/23/2021	1,424.25
					Account Total	1,424.25
	Minor Equipment					
	PCard JE	00031	989953	383751	1/23/2021	236.97
	PCard JE	00031	989953	383751	1/23/2021	835.10

**County of Adams**  
**Vendor Payment Report**

<u>935121</u>	<u>HHS Grant</u>	<u>Fund</u>	<u>Voucher</u>	<u>Batch No</u>	<u>GL Date</u>	<u>Amount</u>
					Account Total	1,072.07
	Operating Supplies					
	PCard JE	00031	989953	383751	1/23/2021	61.00
	PCard JE	00031	989953	383751	1/23/2021	122.00
	PCard JE	00031	989953	383751	1/23/2021	16.28
	PCard JE	00031	989953	383751	1/23/2021	16.28-
	PCard JE	00031	989953	383751	1/23/2021	24.76
	PCard JE	00031	989953	383751	1/23/2021	16.49
	PCard JE	00031	989953	383751	1/23/2021	17.35
					Account Total	241.60
	Other Communications					
	PCard JE	00031	989953	383751	1/23/2021	565.84
					Account Total	565.84
	Other Professional Serv					
	PCard JE	00031	989953	383751	1/23/2021	49.50
	PCard JE	00031	989953	383751	1/23/2021	100.00
	PCard JE	00031	989953	383751	1/23/2021	162.89
					Account Total	312.39
	Telephone					
	CENTURY LINK	00031	989825	383580	2/1/2021	120.76
	CENTURY LINK	00031	989826	383580	2/1/2021	485.86
	CENTURYLINK	00031	989827	383580	2/1/2021	11.86
					Account Total	618.48
	Water/Sewer/Sanitation					
	PCard JE	00031	989953	383751	1/23/2021	105.38
					Account Total	105.38
					Department Total	6,836.96

**County of Adams**  
**Vendor Payment Report**

<u>935621</u>	<u>HS CACFP</u>	<u>Fund</u>	<u>Voucher</u>	<u>Batch No</u>	<u>GL Date</u>	<u>Amount</u>
	Food Supplies					
	PCard JE	00031	989953	383751	1/23/2021	1,204.00
	PCard JE	00031	989953	383751	1/23/2021	782.60
	PCard JE	00031	989953	383751	1/23/2021	541.80
	PCard JE	00031	989953	383751	1/23/2021	36.85
	PCard JE	00031	989953	383751	1/23/2021	541.80
	PCard JE	00031	989953	383751	1/23/2021	541.80
					Account Total	3,648.85
	Operating Supplies					
	PCard JE	00031	989953	383751	1/23/2021	339.60
					Account Total	339.60
					Department Total	3,988.45

**County of Adams**  
**Vendor Payment Report**

<u>500005007000</u>	<u>Human Serv Info Tech Comm Supp</u>	<u>Fund</u>	<u>Voucher</u>	<u>Batch No</u>	<u>GL Date</u>	<u>Amount</u>
	Equipment Rental					
	PCard JE	00015	989953	383751	1/23/2021	<u>124.62</u>
					Account Total	<u>124.62</u>
					Department Total	<u><u>124.62</u></u>

**County of Adams**  
**Vendor Payment Report**

<u>305006004000</u>	<u>IM Support - EBT Ch Sup Unit</u>	<u>Fund</u>	<u>Voucher</u>	<u>Batch No</u>	<u>GL Date</u>	<u>Amount</u>
	Operating Supplies					
	PCard JE	00015	989953	383751	1/23/2021	65.44
	PCard JE	00015	989953	383751	1/23/2021	10.44
	PCard JE	00015	989953	383751	1/23/2021	19.02
	PCard JE	00015	989953	383751	1/23/2021	288.32
					Account Total	<u>383.22</u>
					Department Total	<u><u>383.22</u></u>

**County of Adams**  
**Vendor Payment Report**

<u>306033504010</u>	<u>Income Maintenance Direct</u>	<u>Fund</u>	<u>Voucher</u>	<u>Batch No</u>	<u>GL Date</u>	<u>Amount</u>
	Printing External					
	PCard JE	00015	989953	383751	1/23/2021	850.00
	PCard JE	00015	989953	383751	1/23/2021	300.00
	PCard JE	00015	989953	383751	1/23/2021	1,200.00
					Account Total	2,350.00
	Equipment Rental					
	PCard JE	00015	989953	383751	1/23/2021	281.64
	PCard JE	00015	989953	383751	1/23/2021	281.64
	PCard JE	00015	989953	383751	1/23/2021	281.64
	PCard JE	00015	989953	383751	1/23/2021	281.64
	PCard JE	00015	989953	383751	1/23/2021	173.80
	PCard JE	00015	989953	383751	1/23/2021	184.21
	PCard JE	00015	989953	383751	1/23/2021	124.62
	PCard JE	00015	989953	383751	1/23/2021	124.62
	PCard JE	00015	989953	383751	1/23/2021	130.60
	PCard JE	00015	989953	383751	1/23/2021	149.23
	PCard JE	00015	989953	383751	1/23/2021	149.23
	PCard JE	00015	989953	383751	1/23/2021	149.23
	PCard JE	00015	989953	383751	1/23/2021	130.60
	PCard JE	00015	989953	383751	1/23/2021	301.07
	PCard JE	00015	989953	383751	1/23/2021	22.71
	PCard JE	00015	989953	383751	1/23/2021	129.72
	PCard JE	00015	989953	383751	1/23/2021	225.00
	PCard JE	00015	989953	383751	1/23/2021	62.72
	PCard JE	00015	989953	383751	1/23/2021	12.89
	PCard JE	00015	989953	383751	1/23/2021	1.26
	PCard JE	00015	989953	383751	1/23/2021	11.32
	PCard JE	00015	989953	383751	1/23/2021	3.93
	PCard JE	00015	989953	383751	1/23/2021	4.35
	PCard JE	00015	989953	383751	1/23/2021	255.18
	PCard JE	00015	989953	383751	1/23/2021	14.18
	PCard JE	00015	989953	383751	1/23/2021	1.59
	PCard JE	00015	989953	383751	1/23/2021	85.43
	PCard JE	00015	989953	383751	1/23/2021	83.20
	PCard JE	00015	989953	383751	1/23/2021	9.40



**County of Adams**  
**Vendor Payment Report**

<u>306033504010</u>	<u>Income Maintenance Direct</u>	<u>Fund</u>	<u>Voucher</u>	<u>Batch No</u>	<u>GL Date</u>	<u>Amount</u>
	PCard JE	00015	989953	383751	1/23/2021	.64
	PCard JE	00015	989953	383751	1/23/2021	7.29
	PCard JE	00015	989953	383751	1/23/2021	3.75
	PCard JE	00015	989953	383751	1/23/2021	3.07
					Account Total	3,681.40
	Membership Dues					
	PCard JE	00015	989953	383751	1/23/2021	30.00
					Account Total	30.00
	Operating Supplies					
	PCard JE	00015	989953	383751	1/23/2021	65.93
	PCard JE	00015	989953	383751	1/23/2021	494.85
	PCard JE	00015	989953	383751	1/23/2021	2,030.13
					Account Total	2,590.91
	Other Communications					
	PCard JE	00015	989953	383751	1/23/2021	666.70
					Account Total	666.70
	Other Professional Serv					
	PCard JE	00015	989953	383751	1/23/2021	120.92
					Account Total	120.92
					Department Total	9,439.93

**County of Adams**  
**Vendor Payment Report**

<u>8613</u>	<u>Insurance - UHC EPO Medical</u>	<u>Fund</u>	<u>Voucher</u>	<u>Batch No</u>	<u>GL Date</u>	<u>Amount</u>
	Claims					
	UNITED HEALTH CARE INSURANCE C	00019	989955	383755	2/3/2021	192,064.84
	UNITED HEALTH CARE INSURANCE C	00019	989956	383755	2/3/2021	74,163.59
					Account Total	266,228.43
					Department Total	266,228.43

**County of Adams**  
**Vendor Payment Report**

<u>8622</u>	<u>Insurance -Benefits &amp; Wellness</u>	<u>Fund</u>	<u>Voucher</u>	<u>Batch No</u>	<u>GL Date</u>	<u>Amount</u>
	Operating Supplies					
	PCard JE	00019	989953	383751	1/23/2021	13.99
	PCard JE	00019	989953	383751	1/23/2021	16.95
	PCard JE	00019	989953	383751	1/23/2021	29.97
					Account Total	60.91
	Special Events					
	PCard JE	00019	989953	383751	1/23/2021	43.99-
	PCard JE	00019	989953	383751	1/23/2021	400.00
	PCard JE	00019	989953	383751	1/23/2021	100.00
					Account Total	456.01
					Department Total	516.92

**County of Adams**  
**Vendor Payment Report**

<u>8614</u>	<u>Insurance- Delta Dental</u>	<u>Fund</u>	<u>Voucher</u>	<u>Batch No</u>	<u>GL Date</u>	<u>Amount</u>
	Self-Insurance Claims					
	DELTA DENTAL OF COLO	00019	989996	383794	2/3/2021	18,114.10
	DELTA DENTAL OF COLO	00019	989997	383794	2/3/2021	9,962.00
	DELTA DENTAL OF COLO	00019	989998	383794	2/3/2021	25,063.80
	DELTA DENTAL OF COLO	00019	989999	383794	2/3/2021	20,461.28
	DELTA DENTAL OF COLO	00019	990001	383794	2/3/2021	92.00
	DELTA DENTAL OF COLO	00019	990002	383794	2/3/2021	33,292.20
	DELTA DENTAL OF COLO	00019	990003	383794	2/3/2021	19,404.50
	DELTA DENTAL OF COLO	00019	990006	383794	2/3/2021	130.00
					Account Total	126,519.88
					Department Total	126,519.88

**County of Adams**  
**Vendor Payment Report**

<u>19</u>	<u>Insurance Fund</u>	<u>Fund</u>	<u>Voucher</u>	<u>Batch No</u>	<u>GL Date</u>	<u>Amount</u>
	Received not Vouchered Clrg					
	BAKKEN CHRISTEN	00019	990047	383900	2/4/2021	480.00
	THE TABEN GROUP	00019	990109	384040	2/5/2021	900.00
					Account Total	1,380.00
					Department Total	1,380.00

**County of Adams**  
**Vendor Payment Report**

<u>8611</u>	<u>Insurance- Property/Casualty</u>	<u>Fund</u>	<u>Voucher</u>	<u>Batch No</u>	<u>GL Date</u>	<u>Amount</u>
	Auto Physical Damage					
	FARIS MACHINERY CO	00019	989928	383685	2/2/2021	13,457.92
					Account Total	13,457.92
	General Liab - Other than Prop					
	ARGO SUSAN L	00019	989669	383445	1/28/2021	47,221.09
	KING & GREISEN LLP	00019	989670	383445	1/28/2021	12,778.91
					Account Total	60,000.00
					Department Total	73,457.92

**County of Adams**  
**Vendor Payment Report**

<u>8617</u>	<u>Insurance- Workers Comp</u>	<u>Fund</u>	<u>Voucher</u>	<u>Batch No</u>	<u>GL Date</u>	<u>Amount</u>
	Workers Compensation					
	TRISTAR RISK MANAGEMENT	00019	989213	383205	1/27/2021	87,500.00
	TRISTAR RISK MANAGEMENT	00019	989886	383670	2/2/2021	54,981.91
					Account Total	142,481.91
					Department Total	142,481.91

**County of Adams**  
**Vendor Payment Report**

<u>1061</u>	<u>IT Administration</u>	<u>Fund</u>	<u>Voucher</u>	<u>Batch No</u>	<u>GL Date</u>	<u>Amount</u>
	Equipment Rental					
	PCard JE	00001	989953	383751	1/23/2021	156.74
	PCard JE	00001	989953	383751	1/23/2021	124.62
	PCard JE	00001	989953	383751	1/23/2021	130.60
	PCard JE	00001	989953	383751	1/23/2021	12.74
	PCard JE	00001	989953	383751	1/23/2021	2.36
	PCard JE	00001	989953	383751	1/23/2021	.21
	PCard JE	00001	989953	383751	1/23/2021	5.43
	PCard JE	00001	989953	383751	1/23/2021	3.14
	PCard JE	00001	989953	383751	1/23/2021	.90
	PCard JE	00001	989953	383751	1/23/2021	156.74
	PCard JE	00001	989953	383751	1/23/2021	124.62
	PCard JE	00001	989953	383751	1/23/2021	130.60
	PCard JE	00001	989953	383751	1/23/2021	27.01
	PCard JE	00001	989953	383751	1/23/2021	8.13
	PCard JE	00001	989953	383751	1/23/2021	.04
					Account Total	883.88
	ISP Services					
	PCard JE	00001	989953	383751	1/23/2021	67.54
	PCard JE	00001	989953	383751	1/23/2021	15.40
					Account Total	82.94
	Operating Supplies					
	PCard JE	00001	989953	383751	1/23/2021	100.14
					Account Total	100.14
	Special Events					
	PCard JE	00001	989953	383751	1/23/2021	839.20
					Account Total	839.20
	Telephone					
	PCard JE	00001	989953	383751	1/23/2021	16.25
					Account Total	16.25
					Department Total	1,922.41



**County of Adams**  
**Vendor Payment Report**

<u>1056</u>	<u>IT Help Desk &amp; Servers</u>	<u>Fund</u>	<u>Voucher</u>	<u>Batch No</u>	<u>GL Date</u>	<u>Amount</u>
	Computers					
	PCard JE	00001	989953	383751	1/23/2021	123.29
	PCard JE	00001	989953	383751	1/23/2021	1,043.61
	PCard JE	00001	989953	383751	1/23/2021	35.97
					Account Total	1,202.87
	Other Communications					
	PCard JE	00001	989953	383751	1/23/2021	155.37
					Account Total	155.37
	Software and Licensing					
	PCard JE	00001	989953	383751	1/23/2021	4.16
					Account Total	4.16
					Department Total	1,362.40

**County of Adams**  
**Vendor Payment Report**

<u>1058</u>	<u>IT Network/Telecom</u>	<u>Fund</u>	<u>Voucher</u>	<u>Batch No</u>	<u>GL Date</u>	<u>Amount</u>
	Other Communications					
	PCard JE	00001	989953	383751	1/23/2021	31.57
	PCard JE	00001	989953	383751	1/23/2021	300.00
	PCard JE	00001	989953	383751	1/23/2021	49.98
	PCard JE	00001	989953	383751	1/23/2021	300.00-
	PCard JE	00001	989953	383751	1/23/2021	187.80
	PCard JE	00001	989953	383751	1/23/2021	303.66
	PCard JE	00001	989953	383751	1/23/2021	6,576.40
					Account Total	7,149.41
	Telephone					
	PCard JE	00001	989953	383751	1/23/2021	889.14
	PCard JE	00001	989953	383751	1/23/2021	37.83
	PCard JE	00001	989953	383751	1/23/2021	26,160.93
					Account Total	27,087.90
					Department Total	34,237.31

**County of Adams**  
**Vendor Payment Report**

<u>1054</u>	<u>IT Security</u>	<u>Fund</u>	<u>Voucher</u>	<u>Batch No</u>	<u>GL Date</u>	<u>Amount</u>
	Education & Training					
	PCard JE	00001	989953	383751	1/23/2021	125.00
	PCard JE	00001	989953	383751	1/23/2021	500.00
					Account Total	<u>625.00</u>
					Department Total	<u><u>625.00</u></u>

**County of Adams**  
**Vendor Payment Report**

<u>305091008000</u>	<u>IV-D Admin</u>	<u>Fund</u>	<u>Voucher</u>	<u>Batch No</u>	<u>GL Date</u>	<u>Amount</u>
	Other Professional Serv					
	PCard JE	00015	989953	383751	1/23/2021	232.38
					Account Total	232.38
	Computers					
	PCard JE	00015	989953	383751	1/23/2021	841.90
	PCard JE	00015	989953	383751	1/23/2021	597.08
					Account Total	1,438.98
	Equipment Rental					
	PCard JE	00015	989953	383751	1/23/2021	281.64
	PCard JE	00015	989953	383751	1/23/2021	173.80
	PCard JE	00015	989953	383751	1/23/2021	149.23
	PCard JE	00015	989953	383751	1/23/2021	149.23
	PCard JE	00015	989953	383751	1/23/2021	225.22
	PCard JE	00015	989953	383751	1/23/2021	14.68
	PCard JE	00015	989953	383751	1/23/2021	4.06
	PCard JE	00015	989953	383751	1/23/2021	5.17
	PCard JE	00015	989953	383751	1/23/2021	167.44
	PCard JE	00015	989953	383751	1/23/2021	12.86
	PCard JE	00015	989953	383751	1/23/2021	4.27
	PCard JE	00015	989953	383751	1/23/2021	2.65
					Account Total	1,190.25
	Operating Supplies					
	PCard JE	00015	989953	383751	1/23/2021	168.00
	PCard JE	00015	989953	383751	1/23/2021	205.85
	PCard JE	00015	989953	383751	1/23/2021	7.65
	PCard JE	00015	989953	383751	1/23/2021	28.41
	PCard JE	00015	989953	383751	1/23/2021	106.17
	PCard JE	00015	989953	383751	1/23/2021	1,906.06
					Account Total	2,422.14
					Department Total	5,283.75

**County of Adams**  
**Vendor Payment Report**

<u>2010W5081506</u>	<u>Kinship Navigation Pilot</u>	<u>Fund</u>	<u>Voucher</u>	<u>Batch No</u>	<u>GL Date</u>	<u>Amount</u>
	County Client/Provider					
	PCard JE	00015	989953	383751	1/23/2021	114.79
	PCard JE	00015	989953	383751	1/23/2021	131.10
	PCard JE	00015	989953	383751	1/23/2021	301.14
	PCard JE	00015	989953	383751	1/23/2021	304.00
	PCard JE	00015	989953	383751	1/23/2021	146.66
	PCard JE	00015	989953	383751	1/23/2021	175.24
	PCard JE	00015	989953	383751	1/23/2021	427.92
	PCard JE	00015	989953	383751	1/23/2021	127.48
	PCard JE	00015	989953	383751	1/23/2021	98.80
	PCard JE	00015	989953	383751	1/23/2021	329.00
	PCard JE	00015	989953	383751	1/23/2021	169.00
	PCard JE	00015	989953	383751	1/23/2021	69.91
	PCard JE	00015	989953	383751	1/23/2021	359.00
	PCard JE	00015	989953	383751	1/23/2021	22.99
	PCard JE	00015	989953	383751	1/23/2021	226.51
	PCard JE	00015	989953	383751	1/23/2021	99.94
	PCard JE	00015	989953	383751	1/23/2021	72.87
	PCard JE	00015	989953	383751	1/23/2021	49.98
	PCard JE	00015	989953	383751	1/23/2021	82.58
	PCard JE	00015	989953	383751	1/23/2021	39.86
	PCard JE	00015	989953	383751	1/23/2021	150.96
	PCard JE	00015	989953	383751	1/23/2021	45.84-
	PCard JE	00015	989953	383751	1/23/2021	179.24-
					Account Total	3,274.65
					Department Total	3,274.65

**County of Adams**  
**Vendor Payment Report**

<u>1081</u>	<u>Long Range Strategic Planning</u>	<u>Fund</u>	<u>Voucher</u>	<u>Batch No</u>	<u>GL Date</u>	<u>Amount</u>
	Operating Supplies					
	PCard JE	00001	989953	383751	1/23/2021	12.80
	PCard JE	00001	989953	383751	1/23/2021	73.62
	PCard JE	00001	989953	383751	1/23/2021	13.34
	PCard JE	00001	989953	383751	1/23/2021	31.10
					Account Total	130.86
					Department Total	130.86

**County of Adams**  
**Vendor Payment Report**

<u>700005007000</u>	<u>Mail/File Svcs Common Support</u>	<u>Fund</u>	<u>Voucher</u>	<u>Batch No</u>	<u>GL Date</u>	<u>Amount</u>
	Operating Supplies					
	PCard JE	00015	989953	383751	1/23/2021	26.16
	PCard JE	00015	989953	383751	1/23/2021	129.11
					Account Total	<u>155.27</u>
					Department Total	<u><u>155.27</u></u>

**County of Adams**  
**Vendor Payment Report**

<u>3060M1004010</u>	<u>Medicaid Direct</u>	<u>Fund</u>	<u>Voucher</u>	<u>Batch No</u>	<u>GL Date</u>	<u>Amount</u>
	Other Professional Serv PCard JE	00015	989953	383751	1/23/2021	71.96
					Account Total	71.96
					Department Total	71.96



**County of Adams**  
**Vendor Payment Report**

<u>935511</u>	<u>MISC PROJECTS</u>	<u>Fund</u>	<u>Voucher</u>	<u>Batch No</u>	<u>GL Date</u>	<u>Amount</u>
	Headstart Classroom Supply					
	PCard JE	00031	989953	383751	1/23/2021	44.16
	PCard JE	00031	989953	383751	1/23/2021	42.00
					Account Total	86.16
	Operating Supplies					
	PCard JE	00031	989953	383751	1/23/2021	12.74-
					Account Total	12.74-
	Special Events					
	PCard JE	00031	989953	383751	1/23/2021	406.00
					Account Total	406.00
	Subscrip/Publications					
	PCard JE	00031	989953	383751	1/23/2021	31.39-
					Account Total	31.39-
					Department Total	448.03

**County of Adams**  
**Vendor Payment Report**

<u>99650</u>	<u>Misc Reimbursable Purchases</u>	<u>Fund</u>	<u>Voucher</u>	<u>Batch No</u>	<u>GL Date</u>	<u>Amount</u>
	Clnt Trng- OJT					
	BOULDER MEDICAL CENTER PC	00035	989074	382172	1/25/2021	3,000.00
	VCA ASPENWOOD ANIMAL HOSPITAL	00035	989778	383565	2/1/2021	3,000.00
	VCA ASPENWOOD ANIMAL HOSPITAL	00035	989782	383565	2/1/2021	3,000.00
					Account Total	9,000.00
					Department Total	9,000.00

**County of Adams**  
**Vendor Payment Report**

<u>97813</u>	<u>MSFW Housing Inspection</u>	<u>Fund</u>	<u>Voucher</u>	<u>Batch No</u>	<u>GL Date</u>	<u>Amount</u>
	Other Communications					
	VERIZON WIRELESS	00035	989935	383688	2/2/2021	<u>169.53</u>
					Account Total	<u>169.53</u>
					Department Total	<u><u>169.53</u></u>

**County of Adams**  
**Vendor Payment Report**

<u>1190</u>	<u>One-Stop Customer Service Cent</u>	<u>Fund</u>	<u>Voucher</u>	<u>Batch No</u>	<u>GL Date</u>	<u>Amount</u>
	Operating Supplies					
	PCard JE	00001	989953	383751	1/23/2021	12.79
	PCard JE	00001	989953	383751	1/23/2021	13.35
	PCard JE	00001	989953	383751	1/23/2021	17.82
					Account Total	43.96
	Other Communications					
	PCard JE	00001	989953	383751	1/23/2021	52.49
					Account Total	52.49
	Other Professional Serv					
	PCard JE	00001	989953	383751	1/23/2021	19.99
					Account Total	19.99
					Department Total	116.44

**County of Adams**  
**Vendor Payment Report**

<u>6107</u>	<u>Open Space Projects</u>	<u>Fund</u>	<u>Voucher</u>	<u>Batch No</u>	<u>GL Date</u>	<u>Amount</u>
	Gas & Electricity					
	PCard JE	00027	989953	383751	1/23/2021	44.45
	PCard JE	00027	989953	383751	1/23/2021	47.52
	PCard JE	00027	989953	383751	1/23/2021	541.91
	PCard JE	00027	989953	383751	1/23/2021	20.00
					Account Total	653.88
	Infrastruc Rep & Maint					
	PCard JE	00027	989953	383751	1/23/2021	1,191.25
					Account Total	1,191.25
	Operating Supplies					
	PCard JE	00027	989953	383751	1/23/2021	1,085.89
	PCard JE	00027	989953	383751	1/23/2021	99.00
	PCard JE	00027	989953	383751	1/23/2021	322.50
	PCard JE	00027	989953	383751	1/23/2021	448.00
					Account Total	1,955.39
					Department Total	3,800.52

**County of Adams**  
**Vendor Payment Report**

<u>27</u>	<u>Open Space Projects Fund</u>	<u>Fund</u>	<u>Voucher</u>	<u>Batch No</u>	<u>GL Date</u>	<u>Amount</u>
	Received not Vouchered Clrg					
	DHM DESIGNS	00027	990033	383900	2/4/2021	<u>3,307.50</u>
					Account Total	<u>3,307.50</u>
					Department Total	<u><u>3,307.50</u></u>

**County of Adams**  
**Vendor Payment Report**

<u>6201</u>	<u>Open Space Tax- Admin</u>	<u>Fund</u>	<u>Voucher</u>	<u>Batch No</u>	<u>GL Date</u>	<u>Amount</u>
	Operating Supplies					
	PCard JE	00028	989953	383751	1/23/2021	27.96
	PCard JE	00028	989953	383751	1/23/2021	13.98
					Account Total	41.94
	Public Relations					
	PCard JE	00028	989953	383751	1/23/2021	1,777.35
	PCard JE	00028	989953	383751	1/23/2021	1,090.57
	PCard JE	00028	989953	383751	1/23/2021	4,195.29
					Account Total	7,063.21
					Department Total	7,105.15

**County of Adams**  
**Vendor Payment Report**

<u>6202</u>	<u>Open Space Tax- Grants</u>	<u>Fund</u>	<u>Voucher</u>	<u>Batch No</u>	<u>GL Date</u>	<u>Amount</u>
	Grants to Other Instit					
	BIRD CONSERVANCY OF THE ROCKIE	00028	990007	383799	2/3/2021	19,008.75
	HYLAND HILLS PARK AND RECREATI	00028	989969	383766	2/3/2021	309,000.00
	LUBIRDS LIGHT FOUNDATION	00028	988130	381455	1/5/2021	68,038.29
	THORNTON CITY OF	00028	988375	381745	1/7/2021	13,979.80
					Account Total	410,026.84
					Department Total	410,026.84



**County of Adams**  
**Vendor Payment Report**

<u>1015</u>	<u>People Services</u>	<u>Fund</u>	<u>Voucher</u>	<u>Batch No</u>	<u>GL Date</u>	<u>Amount</u>
	CIA					
	PCard JE	00001	989953	383751	1/23/2021	824.13
					Account Total	824.13
	Education & Training					
	PCard JE	00001	989953	383751	1/23/2021	25.00
					Account Total	25.00
	Equipment Rental					
	PCard JE	00001	989953	383751	1/23/2021	206.10
	PCard JE	00001	989953	383751	1/23/2021	206.10
	PCard JE	00001	989953	383751	1/23/2021	127.64
	PCard JE	00001	989953	383751	1/23/2021	3.64
	PCard JE	00001	989953	383751	1/23/2021	79.48
	PCard JE	00001	989953	383751	1/23/2021	2.50
	PCard JE	00001	989953	383751	1/23/2021	206.10
	PCard JE	00001	989953	383751	1/23/2021	206.10
	PCard JE	00001	989953	383751	1/23/2021	64.79
	PCard JE	00001	989953	383751	1/23/2021	7.04
					Account Total	1,109.49
	Membership Dues					
	PCard JE	00001	989953	383751	1/23/2021	219.00
					Account Total	219.00
	Minor Equipment					
	PCard JE	00001	989953	383751	1/23/2021	329.99
					Account Total	329.99
	Operating Supplies					
	PCard JE	00001	989953	383751	1/23/2021	169.56
	PCard JE	00001	989953	383751	1/23/2021	21.77
	PCard JE	00001	989953	383751	1/23/2021	32.50
	PCard JE	00001	989953	383751	1/23/2021	16.50
	PCard JE	00001	989953	383751	1/23/2021	23.99
	PCard JE	00001	989953	383751	1/23/2021	31.78
					Account Total	296.10
	Other Professional Serv					
	PCard JE	00001	989953	383751	1/23/2021	110.00

**County of Adams**  
**Vendor Payment Report**

<u>1015</u>	<u>People Services</u>	<u>Fund</u>	<u>Voucher</u>	<u>Batch No</u>	<u>GL Date</u>	<u>Amount</u>
	PCard JE	00001	989953	383751	1/23/2021	354.64
	PCard JE	00001	989953	383751	1/23/2021	300.00
					Account Total	764.64
	Printing External					
	PCard JE	00001	989953	383751	1/23/2021	876.04
					Account Total	876.04
	Subscrip/Publications					
	PCard JE	00001	989953	383751	1/23/2021	18.00
					Account Total	18.00
					Department Total	4,462.39

**County of Adams**  
**Vendor Payment Report**

<u>1034</u>	<u>People Services-Social Svcs</u>	<u>Fund</u>	<u>Voucher</u>	<u>Batch No</u>	<u>GL Date</u>	<u>Amount</u>
	Software and Licensing					
	PCard JE	00001	989953	383751	1/23/2021	9.97
	PCard JE	00001	989953	383751	1/23/2021	9.97
	PCard JE	00001	989953	383751	1/23/2021	9.97
					Account Total	<u>29.91</u>
					Department Total	<u><u>29.91</u></u>

**County of Adams**  
**Vendor Payment Report**

<u>3133</u>	<u>PKS - Park Rangers</u>	<u>Fund</u>	<u>Voucher</u>	<u>Batch No</u>	<u>GL Date</u>	<u>Amount</u>
	Operating Supplies					
	PCard JE	00001	989953	383751	1/23/2021	1,175.00
	PCard JE	00001	989953	383751	1/23/2021	20.00
	PCard JE	00001	989953	383751	1/23/2021	46.34
	PCard JE	00001	989953	383751	1/23/2021	28.75
					Account Total	1,270.09
	Uniforms & Cleaning					
	PCard JE	00001	989953	383751	1/23/2021	295.00
					Account Total	295.00
					Department Total	1,565.09

**County of Adams**  
**Vendor Payment Report**

<u>2061</u>	<u>PKS - Weed &amp; Pest</u>	<u>Fund</u>	<u>Voucher</u>	<u>Batch No</u>	<u>GL Date</u>	<u>Amount</u>
	Membership Dues					
	PCard JE	00001	989953	383751	1/23/2021	400.00
					Account Total	400.00
	Operating Supplies					
	PCard JE	00001	989953	383751	1/23/2021	68.09
	PCard JE	00001	989953	383751	1/23/2021	219.00
	PCard JE	00001	989953	383751	1/23/2021	339.24
	PCard JE	00001	989953	383751	1/23/2021	146.97
	PCard JE	00001	989953	383751	1/23/2021	1,940.00
	PCard JE	00001	989953	383751	1/23/2021	2,300.00
					Account Total	5,013.30
	Other Professional Serv					
	PCard JE	00001	989953	383751	1/23/2021	187.00
	PCard JE	00001	989953	383751	1/23/2021	205.00
					Account Total	392.00
	Uniforms & Cleaning					
	PCard JE	00001	989953	383751	1/23/2021	97.17
	PCard JE	00001	989953	383751	1/23/2021	101.67
	PCard JE	00001	989953	383751	1/23/2021	183.56
					Account Total	382.40
					Department Total	<u>6,187.70</u>

**County of Adams**  
**Vendor Payment Report**

<u>5011</u>	<u>PKS- Administration</u>	<u>Fund</u>	<u>Voucher</u>	<u>Batch No</u>	<u>GL Date</u>	<u>Amount</u>
	Equipment Rental					
	PCard JE	00001	989953	383751	1/23/2021	173.80
	PCard JE	00001	989953	383751	1/23/2021	136.32
	PCard JE	00001	989953	383751	1/23/2021	9.41
	PCard JE	00001	989953	383751	1/23/2021	63.12
	PCard JE	00001	989953	383751	1/23/2021	173.80
	PCard JE	00001	989953	383751	1/23/2021	4.34
	PCard JE	00001	989953	383751	1/23/2021	131.98
	PCard JE	00001	989953	383751	1/23/2021	131.98
	PCard JE	00001	989953	383751	1/23/2021	131.98
	PCard JE	00001	989953	383751	1/23/2021	8.68
	PCard JE	00001	989953	383751	1/23/2021	1.13
					Account Total	966.54
	Membership Dues					
	PCard JE	00001	989953	383751	1/23/2021	196.00
					Account Total	196.00
	Operating Supplies					
	GREAT ECOLOGY & ENVIRONMENTS I	00001	989949	383750	2/3/2021	1,286.25
	PCard JE	00001	989953	383751	1/23/2021	1,034.35
	PCard JE	00001	989953	383751	1/23/2021	8.99
	PCard JE	00001	989953	383751	1/23/2021	33.98
	PCard JE	00001	989953	383751	1/23/2021	25.57
	PCard JE	00001	989953	383751	1/23/2021	28.75
	PCard JE	00001	989953	383751	1/23/2021	12.52
	PCard JE	00001	989953	383751	1/23/2021	30.01
	PCard JE	00001	989953	383751	1/23/2021	598.39
	PCard JE	00001	989953	383751	1/23/2021	502.27
	PCard JE	00001	989953	383751	1/23/2021	1.01-
	PCard JE	00001	989953	383751	1/23/2021	660.00
	PCard JE	00001	989953	383751	1/23/2021	1,079.16
	PCard JE	00001	989953	383751	1/23/2021	225.00
	PCard JE	00001	989953	383751	1/23/2021	19.98
	PCard JE	00001	989953	383751	1/23/2021	65.98
	PCard JE	00001	989953	383751	1/23/2021	115.00
	PCard JE	00001	989953	383751	1/23/2021	124.00

**County of Adams**  
**Vendor Payment Report**

<u>5011</u>	<u>PKS- Administration</u>	<u>Fund</u>	<u>Voucher</u>	<u>Batch No</u>	<u>GL Date</u>	<u>Amount</u>
					Account Total	5,849.19
	Special Assessment Payments					
	WELLINGTON RESERVOIR COMPANY	00001	989952	383750	2/3/2021	480.00
					Account Total	480.00
					Department Total	7,491.73

**County of Adams**  
**Vendor Payment Report**

<u>5017</u>	<u>PKS- Brantner Mine Lake Restrn</u>	<u>Fund</u>	<u>Voucher</u>	<u>Batch No</u>	<u>GL Date</u>	<u>Amount</u>
	Other Professional Serv					
	PCard JE	00001	989953	383751	1/23/2021	<u>3,500.00</u>
					Account Total	<u>3,500.00</u>
					Department Total	<u><u>3,500.00</u></u>



**County of Adams**  
**Vendor Payment Report**

<u>5010</u>	<u>PKS- Fair</u>	<u>Fund</u>	<u>Voucher</u>	<u>Batch No</u>	<u>GL Date</u>	<u>Amount</u>
	Education & Training					
	PCard JE	00001	989953	383751	1/23/2021	156.00
					Account Total	156.00
	Fair Expenses-General					
	PCard JE	00001	989953	383751	1/23/2021	480.00
					Account Total	480.00
	Food Supplies					
	PCard JE	00001	989953	383751	1/23/2021	54.39-
					Account Total	54.39-
	Membership Dues					
	PCard JE	00001	989953	383751	1/23/2021	190.00
	PCard JE	00001	989953	383751	1/23/2021	50.00
					Account Total	240.00
	Operating Supplies					
	PCard JE	00001	989953	383751	1/23/2021	149.90
	PCard JE	00001	989953	383751	1/23/2021	149.90
	PCard JE	00001	989953	383751	1/23/2021	44.97
	PCard JE	00001	989953	383751	1/23/2021	149.90
	PCard JE	00001	989953	383751	1/23/2021	44.99
	PCard JE	00001	989953	383751	1/23/2021	1,458.64
	PCard JE	00001	989953	383751	1/23/2021	593.72
	PCard JE	00001	989953	383751	1/23/2021	332.71
	PCard JE	00001	989953	383751	1/23/2021	627.50
	PCard JE	00001	989953	383751	1/23/2021	1,297.92
	PCard JE	00001	989953	383751	1/23/2021	525.00
					Account Total	5,375.15
	Public Relations					
	PCard JE	00001	989953	383751	1/23/2021	25.00
	PCard JE	00001	989953	383751	1/23/2021	25.00
					Account Total	50.00
	Regional Park Rentals					
	BUSTAMANTE TONY	00001	989948	383750	2/3/2021	1,400.00
	RODRIGUEZ SONIA	00001	989951	383750	2/3/2021	700.00
					Account Total	2,100.00

**County of Adams**  
**Vendor Payment Report**

<u>5010</u>	<u>PKS- Fair</u>	<u>Fund</u>	<u>Voucher</u>	<u>Batch No</u>	<u>GL Date</u>	<u>Amount</u>
	Special Events					
	PCard JE	00001	989953	383751	1/23/2021	2,367.36
	PCard JE	00001	989953	383751	1/23/2021	1,070.70
	PCard JE	00001	989953	383751	1/23/2021	372.00
	PCard JE	00001	989953	383751	1/23/2021	1,295.44
	PCard JE	00001	989953	383751	1/23/2021	2,760.00
	PCard JE	00001	989953	383751	1/23/2021	2,488.02
					Account Total	<u>10,353.52</u>
	Uniforms & Cleaning					
	PCard JE	00001	989953	383751	1/23/2021	896.26
					Account Total	<u>896.26</u>
					Department Total	<u><u>19,596.54</u></u>

**County of Adams**  
**Vendor Payment Report**

<u>5015</u>	<u>PKS- Grounds Maintenance</u>	<u>Fund</u>	<u>Voucher</u>	<u>Batch No</u>	<u>GL Date</u>	<u>Amount</u>
	Education & Training					
	PCard JE	00001	989953	383751	1/23/2021	25.00
	PCard JE	00001	989953	383751	1/23/2021	85.00
	PCard JE	00001	989953	383751	1/23/2021	25.00
	PCard JE	00001	989953	383751	1/23/2021	25.00
					Account Total	160.00
	Equipment Rental					
	PCard JE	00001	989953	383751	1/23/2021	.92
	PCard JE	00001	989953	383751	1/23/2021	.07
	PCard JE	00001	989953	383751	1/23/2021	.91
					Account Total	1.90
	Maintenance Contracts					
	HYDRO RESOURCES	00001	989950	383750	2/3/2021	1,507.76
					Account Total	1,507.76
	Membership Dues					
	PCard JE	00001	989953	383751	1/23/2021	388.00
					Account Total	388.00
	Operating Supplies					
	PCard JE	00001	989953	383751	1/23/2021	60.60
	PCard JE	00001	989953	383751	1/23/2021	1,923.07
	PCard JE	00001	989953	383751	1/23/2021	98.33
	PCard JE	00001	989953	383751	1/23/2021	77.40
	PCard JE	00001	989953	383751	1/23/2021	7.99
	PCard JE	00001	989953	383751	1/23/2021	80.09
	PCard JE	00001	989953	383751	1/23/2021	421.50
	PCard JE	00001	989953	383751	1/23/2021	348.95
	PCard JE	00001	989953	383751	1/23/2021	1,439.90
	PCard JE	00001	989953	383751	1/23/2021	76.92
					Account Total	4,534.75
	Water/Sewer/Sanitation					
	PCard JE	00001	989953	383751	1/23/2021	3,337.52
					Account Total	3,337.52
					Department Total	9,929.93

**County of Adams**  
**Vendor Payment Report**

<u>5012</u>	<u>PKS- Regional Complex</u>	<u>Fund</u>	<u>Voucher</u>	<u>Batch No</u>	<u>GL Date</u>	<u>Amount</u>
	Fuel, Gas & Oil					
	PCard JE	00001	989953	383751	1/23/2021	1,595.38
	PCard JE	00001	989953	383751	1/23/2021	607.02
	PCard JE	00001	989953	383751	1/23/2021	822.86
					Account Total	3,025.26
	Gas & Electricity					
	PCard JE	00001	989953	383751	1/23/2021	77.24
					Account Total	77.24
	Minor Equipment					
	PCard JE	00001	989953	383751	1/23/2021	89.99
					Account Total	89.99
	Operating Supplies					
	PCard JE	00001	989953	383751	1/23/2021	2,300.00
	PCard JE	00001	989953	383751	1/23/2021	8.64
	PCard JE	00001	989953	383751	1/23/2021	19.44
	PCard JE	00001	989953	383751	1/23/2021	42.75
	PCard JE	00001	989953	383751	1/23/2021	72.28
	PCard JE	00001	989953	383751	1/23/2021	248.14
					Account Total	2,691.25
	Repair & Maint Supplies					
	PCard JE	00001	989953	383751	1/23/2021	255.97
	PCard JE	00001	989953	383751	1/23/2021	260.95
	PCard JE	00001	989953	383751	1/23/2021	476.72
	PCard JE	00001	989953	383751	1/23/2021	56.42
					Account Total	1,050.06
	Tires					
	PCard JE	00001	989953	383751	1/23/2021	591.04
					Account Total	591.04
	Vehicle Parts & Supplies					
	PCard JE	00001	989953	383751	1/23/2021	97.96
	PCard JE	00001	989953	383751	1/23/2021	420.44
	PCard JE	00001	989953	383751	1/23/2021	36.42
	PCard JE	00001	989953	383751	1/23/2021	750.70
	PCard JE	00001	989953	383751	1/23/2021	132.31

**County of Adams**  
**Vendor Payment Report**

<u>5012</u>	<u>PKS- Regional Complex</u>	<u>Fund</u>	<u>Voucher</u>	<u>Batch No</u>	<u>GL Date</u>	<u>Amount</u>
	PCard JE	00001	989953	383751	1/23/2021	94.42
	PCard JE	00001	989953	383751	1/23/2021	225.45
	PCard JE	00001	989953	383751	1/23/2021	60.90
					Account Total	1,818.60
					Department Total	9,343.44

**County of Adams**  
**Vendor Payment Report**

<u>5016</u>	<u>PKS- Trail Ranger Patrol</u>	<u>Fund</u>	<u>Voucher</u>	<u>Batch No</u>	<u>GL Date</u>	<u>Amount</u>
	Education & Training					
	PCard JE	00001	989953	383751	1/23/2021	540.00
	PCard JE	00001	989953	383751	1/23/2021	40.00
					Account Total	580.00
	Membership Dues					
	PCard JE	00001	989953	383751	1/23/2021	291.00
					Account Total	291.00
	Operating Supplies					
	PCard JE	00001	989953	383751	1/23/2021	5.00
	PCard JE	00001	989953	383751	1/23/2021	5.00
	PCard JE	00001	989953	383751	1/23/2021	661.30
	PCard JE	00001	989953	383751	1/23/2021	108.67
	PCard JE	00001	989953	383751	1/23/2021	119.03
	PCard JE	00001	989953	383751	1/23/2021	713.30
	PCard JE	00001	989953	383751	1/23/2021	47.00
	PCard JE	00001	989953	383751	1/23/2021	696.53
					Account Total	2,355.83
	Uniforms & Cleaning					
	PCard JE	00001	989953	383751	1/23/2021	400.00
	PCard JE	00001	989953	383751	1/23/2021	169.16
					Account Total	569.16
	Water/Sewer/Sanitation					
	PCard JE	00001	989953	383751	1/23/2021	157.13
	PCard JE	00001	989953	383751	1/23/2021	13.21
	PCard JE	00001	989953	383751	1/23/2021	5,604.05
	PCard JE	00001	989953	383751	1/23/2021	3,120.21
					Account Total	8,894.60
					Department Total	12,690.59

**County of Adams**  
**Vendor Payment Report**

<u>1089</u>	<u>PLN- Boards &amp; Commissions</u>	<u>Fund</u>	<u>Voucher</u>	<u>Batch No</u>	<u>GL Date</u>	<u>Amount</u>
	Other Professional Serv					
	DUPRIEST JOHN FIELDEN	00001	989821	383574	2/1/2021	65.00
	FOREST SEAN	00001	989816	383574	2/1/2021	65.00
	GARNER, ROSIE	00001	989817	383574	2/1/2021	65.00
	HERRERA, AARON	00001	989818	383574	2/1/2021	65.00
	MADDUX THOMAS SCOTT	00001	989822	383574	2/1/2021	65.00
	MARTINEZ JUSTIN PAUL	00001	989815	383574	2/1/2021	65.00
	RICHARDSON SHARON	00001	989819	383574	2/1/2021	65.00
	THOMPSON GREGORY PAUL	00001	989820	383574	2/1/2021	65.00
					Account Total	520.00
					Department Total	520.00

**County of Adams**  
**Vendor Payment Report**

<u>1082</u>	<u>PLN- Development Review</u>	<u>Fund</u>	<u>Voucher</u>	<u>Batch No</u>	<u>GL Date</u>	<u>Amount</u>
	Equipment Rental					
	PCard JE	00001	989953	383751	1/23/2021	1,881.30
	PCard JE	00001	989953	383751	1/23/2021	199.90
	PCard JE	00001	989953	383751	1/23/2021	206.10
	PCard JE	00001	989953	383751	1/23/2021	130.60
	PCard JE	00001	989953	383751	1/23/2021	68.64
	PCard JE	00001	989953	383751	1/23/2021	.09
	PCard JE	00001	989953	383751	1/23/2021	96.38
	PCard JE	00001	989953	383751	1/23/2021	.32
	PCard JE	00001	989953	383751	1/23/2021	206.10
	PCard JE	00001	989953	383751	1/23/2021	130.60
	PCard JE	00001	989953	383751	1/23/2021	110.02
	PCard JE	00001	989953	383751	1/23/2021	.67
					Account Total	3,030.72
	Membership Dues					
	PCard JE	00001	989953	383751	1/23/2021	493.00
	PCard JE	00001	989953	383751	1/23/2021	160.00
	PCard JE	00001	989953	383751	1/23/2021	120.00
					Account Total	773.00
	Operating Supplies					
	PCard JE	00001	989953	383751	1/23/2021	12.80
	PCard JE	00001	989953	383751	1/23/2021	73.62
	PCard JE	00001	989953	383751	1/23/2021	10.00
	PCard JE	00001	989953	383751	1/23/2021	13.34
	PCard JE	00001	989953	383751	1/23/2021	31.10
					Account Total	140.86
	Printing External					
	PCard JE	00001	989953	383751	1/23/2021	225.00
					Account Total	225.00
					Department Total	4,169.58



**County of Adams**  
**Vendor Payment Report**

<b>1039</b>	<b>Poverty Reduction</b>	<b>Fund</b>	<b>Voucher</b>	<b>Batch No</b>	<b>GL Date</b>	<b>Amount</b>
	Operating Supplies					
	PCard JE	00001	989953	383751	1/23/2021	10.99
	PCard JE	00001	989953	383751	1/23/2021	49.99
	PCard JE	00001	989953	383751	1/23/2021	11.35
	PCard JE	00001	989953	383751	1/23/2021	71.96
	PCard JE	00001	989953	383751	1/23/2021	14.99
	PCard JE	00001	989953	383751	1/23/2021	107.94
	PCard JE	00001	989953	383751	1/23/2021	38.79
	PCard JE	00001	989953	383751	1/23/2021	55.96
	PCard JE	00001	989953	383751	1/23/2021	33.99
	PCard JE	00001	989953	383751	1/23/2021	15.98
	PCard JE	00001	989953	383751	1/23/2021	13.96
	PCard JE	00001	989953	383751	1/23/2021	34.99
	PCard JE	00001	989953	383751	1/23/2021	49.99
	PCard JE	00001	989953	383751	1/23/2021	49.99
	PCard JE	00001	989953	383751	1/23/2021	19.39
	PCard JE	00001	989953	383751	1/23/2021	16.71
	PCard JE	00001	989953	383751	1/23/2021	41.97
	PCard JE	00001	989953	383751	1/23/2021	220.56
	PCard JE	00001	989953	383751	1/23/2021	70.28
	PCard JE	00001	989953	383751	1/23/2021	11.35
	PCard JE	00001	989953	383751	1/23/2021	14.03
	PCard JE	00001	989953	383751	1/23/2021	75.26
	PCard JE	00001	989953	383751	1/23/2021	355.50
	PCard JE	00001	989953	383751	1/23/2021	166.63
	PCard JE	00001	989953	383751	1/23/2021	179.90
	PCard JE	00001	989953	383751	1/23/2021	107.94
	PCard JE	00001	989953	383751	1/23/2021	25.99
	PCard JE	00001	989953	383751	1/23/2021	183.80
	PCard JE	00001	989953	383751	1/23/2021	252.31
	PCard JE	00001	989953	383751	1/23/2021	104.84
	PCard JE	00001	989953	383751	1/23/2021	18.94
	PCard JE	00001	989953	383751	1/23/2021	15.99
	PCard JE	00001	989953	383751	1/23/2021	135.96
	PCard JE	00001	989953	383751	1/23/2021	273.20
	PCard JE	00001	989953	383751	1/23/2021	56.94

**County of Adams**  
**Vendor Payment Report**

<u>1039</u>	<u>Poverty Reduction</u>	<u>Fund</u>	<u>Voucher</u>	<u>Batch No</u>	<u>GL Date</u>	<u>Amount</u>
	PCard JE	00001	989953	383751	1/23/2021	398.60
	PCard JE	00001	989953	383751	1/23/2021	53.89
	PCard JE	00001	989953	383751	1/23/2021	131.43
	PCard JE	00001	989953	383751	1/23/2021	320.95
	PCard JE	00001	989953	383751	1/23/2021	18.99
	PCard JE	00001	989953	383751	1/23/2021	86.33
	PCard JE	00001	989953	383751	1/23/2021	96.17
	PCard JE	00001	989953	383751	1/23/2021	71.37
	PCard JE	00001	989953	383751	1/23/2021	139.86
	PCard JE	00001	989953	383751	1/23/2021	75.92
	PCard JE	00001	989953	383751	1/23/2021	55.40
	PCard JE	00001	989953	383751	1/23/2021	252.00
	PCard JE	00001	989953	383751	1/23/2021	11.99
					Account Total	4,621.26
	Special Events					
	PCard JE	00001	989953	383751	1/23/2021	39.99
					Account Total	39.99
	Telephone					
	PCard JE	00001	989953	383751	1/23/2021	45.50
					Account Total	45.50
					Department Total	4,706.75

**County of Adams**  
**Vendor Payment Report**

<u>1068</u>	<u>Public Trustee</u>	<u>Fund</u>	<u>Voucher</u>	<u>Batch No</u>	<u>GL Date</u>	<u>Amount</u>
	Equipment Rental					
	PCard JE	00001	989953	383751	1/23/2021	149.23
	PCard JE	00001	989953	383751	1/23/2021	16.67
	PCard JE	00001	989953	383751	1/23/2021	17.94
	PCard JE	00001	989953	383751	1/23/2021	149.23
					Account Total	333.07
	Operating Supplies					
	PCard JE	00001	989953	383751	1/23/2021	130.85
	PCard JE	00001	989953	383751	1/23/2021	16.29
	PCard JE	00001	989953	383751	1/23/2021	96.50
					Account Total	243.64
	Other Communications					
	VERIZON	00001	989734	383465	1/29/2021	52.49
	VERIZON	00001	989735	383467	1/29/2021	52.64
					Account Total	105.13
					Department Total	681.84

**County of Adams**  
**Vendor Payment Report**

<u>3011</u>	<u>PW - Administration</u>	<u>Fund</u>	<u>Voucher</u>	<u>Batch No</u>	<u>GL Date</u>	<u>Amount</u>
	Equipment Rental					
	PCard JE	00013	989953	383751	1/23/2021	140.36
	PCard JE	00013	989953	383751	1/23/2021	184.21
	PCard JE	00013	989953	383751	1/23/2021	124.62
	PCard JE	00013	989953	383751	1/23/2021	616.86
	PCard JE	00013	989953	383751	1/23/2021	.35
	PCard JE	00013	989953	383751	1/23/2021	205.65
	PCard JE	00013	989953	383751	1/23/2021	.34
	PCard JE	00013	989953	383751	1/23/2021	184.21
	PCard JE	00013	989953	383751	1/23/2021	124.62
	PCard JE	00013	989953	383751	1/23/2021	.51
					Account Total	1,581.73
	Operating Supplies					
	PCard JE	00013	989953	383751	1/23/2021	59.65
	PCard JE	00013	989953	383751	1/23/2021	16.25
	PCard JE	00013	989953	383751	1/23/2021	114.73
	PCard JE	00013	989953	383751	1/23/2021	27.87
					Account Total	218.50
	Software and Licensing					
	PCard JE	00013	989953	383751	1/23/2021	256.08
					Account Total	256.08
					Department Total	2,056.31

**County of Adams**  
**Vendor Payment Report**

<u>3056</u>	<u>PW - Capital Improvement Plan</u>	<u>Fund</u>	<u>Voucher</u>	<u>Batch No</u>	<u>GL Date</u>	<u>Amount</u>
	Land					
	LAND TITLE GUARANTEE COMPANY	00013	989853	383656	2/1/2021	3,038.00
	LAND TITLE GUARANTEE COMPANY	00013	990074	383905	2/3/2021	75,564.00
	LAND TITLE GUARANTEE COMPANY	00013	990099	383938	2/3/2021	67,066.00
					Account Total	<u>145,668.00</u>
					Department Total	<u><u>145,668.00</u></u>

**County of Adams**  
**Vendor Payment Report**

<u>3052</u>	<u>PW - Constr &amp; Inspec</u>	<u>Fund</u>	<u>Voucher</u>	<u>Batch No</u>	<u>GL Date</u>	<u>Amount</u>
	Education & Training					
	PCard JE	00013	989953	383751	1/23/2021	50.00
					Account Total	50.00
	Operating Supplies					
	PCard JE	00013	989953	383751	1/23/2021	215.82
					Account Total	215.82
	Other Communications					
	PCard JE	00013	989953	383751	1/23/2021	3,275.58
					Account Total	3,275.58
	Uniforms & Cleaning					
	PCard JE	00013	989953	383751	1/23/2021	294.75
					Account Total	294.75
					Department Total	3,836.15

**County of Adams**  
**Vendor Payment Report**

<u>3053</u>	<u>PW - Engineering Services</u>	<u>Fund</u>	<u>Voucher</u>	<u>Batch No</u>	<u>GL Date</u>	<u>Amount</u>
	Membership Dues					
	NATIONAL SOCIETY OF PROF ENGIN	00013	988192	381549	1/6/2021	2,332.00
	PCard JE	00013	989953	383751	1/23/2021	50.00
					Account Total	2,382.00
	Operating Supplies					
	PCard JE	00013	989953	383751	1/23/2021	220.00
					Account Total	220.00
	Other Communications					
	PCard JE	00013	989953	383751	1/23/2021	81.70
					Account Total	81.70
					Department Total	2,683.70

**County of Adams**  
**Vendor Payment Report**

<u>3031</u>	<u>PW - Operations &amp; Maintenance</u>	<u>Fund</u>	<u>Voucher</u>	<u>Batch No</u>	<u>GL Date</u>	<u>Amount</u>
	Debris Removal					
	METECH RECYCLING	00013	989769	383564	2/1/2021	835.38
	THE GOODYEAR TIRE AND RUBBER C	00013	989767	383564	2/1/2021	660.00
	THE GOODYEAR TIRE AND RUBBER C	00013	989768	383564	2/1/2021	681.00
					Account Total	2,176.38
	Equipment Rental					
	PCard JE	00013	989953	383751	1/23/2021	155.05
	PCard JE	00013	989953	383751	1/23/2021	124.62
	PCard JE	00013	989953	383751	1/23/2021	29.22
	PCard JE	00013	989953	383751	1/23/2021	1.71
	PCard JE	00013	989953	383751	1/23/2021	8.17
	PCard JE	00013	989953	383751	1/23/2021	1.07
	PCard JE	00013	989953	383751	1/23/2021	155.05
	PCard JE	00013	989953	383751	1/23/2021	124.62
	PCard JE	00013	989953	383751	1/23/2021	8.81
	PCard JE	00013	989953	383751	1/23/2021	2.57
					Account Total	610.89
	Gas & Electricity					
	UNITED POWER (UNION REA)	00013	989789	383568	2/1/2021	23.16
	UNITED POWER (UNION REA)	00013	989790	383568	2/1/2021	48.28
	UNITED POWER (UNION REA)	00013	989791	383568	2/1/2021	16.50
	UNITED POWER (UNION REA)	00013	989792	383568	2/1/2021	16.50
	UNITED POWER (UNION REA)	00013	989793	383568	2/1/2021	16.50
	UNITED POWER (UNION REA)	00013	989794	383568	2/1/2021	53.33
	UNITED POWER (UNION REA)	00013	989795	383568	2/1/2021	62.71
	UNITED POWER (UNION REA)	00013	989796	383568	2/1/2021	151.34
	UNITED POWER (UNION REA)	00013	989797	383568	2/1/2021	147.87
	UNITED POWER (UNION REA)	00013	989798	383568	2/1/2021	51.69
	UNITED POWER (UNION REA)	00013	989799	383568	2/1/2021	34.00
	UNITED POWER (UNION REA)	00013	989800	383568	2/1/2021	156.30
	UNITED POWER (UNION REA)	00013	989801	383568	2/1/2021	166.16
	UNITED POWER (UNION REA)	00013	989802	383568	2/1/2021	20.31
	UNITED POWER (UNION REA)	00013	989803	383568	2/1/2021	52.87
	UNITED POWER (UNION REA)	00013	989804	383568	2/1/2021	58.32
	UNITED POWER (UNION REA)	00013	989805	383568	2/1/2021	69.42



**County of Adams**  
**Vendor Payment Report**

<u>3031</u>	<u>PW - Operations &amp; Maintenance</u>	<u>Fund</u>	<u>Voucher</u>	<u>Batch No</u>	<u>GL Date</u>	<u>Amount</u>
	UNITED POWER (UNION REA)	00013	989806	383568	2/1/2021	41.07
	UNITED POWER (UNION REA)	00013	989807	383568	2/1/2021	66.00
	UNITED POWER (UNION REA)	00013	989809	383568	2/1/2021	33.00
	UNITED POWER (UNION REA)	00013	989810	383568	2/1/2021	36.00
	UNITED POWER (UNION REA)	00013	989811	383568	2/1/2021	88.49
	XCEL ENERGY	00013	989775	383568	2/1/2021	131.72
	XCEL ENERGY	00013	989776	383568	2/1/2021	60.86
	XCEL ENERGY	00013	989777	383568	2/1/2021	211.90
	XCEL ENERGY	00013	989779	383568	2/1/2021	11.77
	XCEL ENERGY	00013	989780	383568	2/1/2021	137.00
	XCEL ENERGY	00013	989781	383568	2/1/2021	48.05
	XCEL ENERGY	00013	989783	383568	2/1/2021	31.95
	XCEL ENERGY	00013	989784	383568	2/1/2021	44.99
	XCEL ENERGY	00013	989785	383568	2/1/2021	143.05
	XCEL ENERGY	00013	989786	383568	2/1/2021	103.83
	XCEL ENERGY	00013	989787	383568	2/1/2021	24,716.79
	XCEL ENERGY	00013	989788	383568	2/1/2021	4,831.70
					Account Total	31,883.43
	Minor Equipment					
	PCard JE	00013	989953	383751	1/23/2021	73.00
	PCard JE	00013	989953	383751	1/23/2021	19.95
					Account Total	92.95
	Operating Supplies					
	ALSCO AMERICAN INDUSTRIAL	00013	989761	383564	2/1/2021	102.77
	ALSCO AMERICAN INDUSTRIAL	00013	989762	383564	2/1/2021	88.40
	ALSCO AMERICAN INDUSTRIAL	00013	989763	383564	2/1/2021	88.40
	CINTAS FIRST AID & SAFETY	00013	989764	383564	2/1/2021	170.07
	PCard JE	00013	989953	383751	1/23/2021	57.46
	PCard JE	00013	989953	383751	1/23/2021	24.99
	PCard JE	00013	989953	383751	1/23/2021	54.57
	PCard JE	00013	989953	383751	1/23/2021	162.23
	PCard JE	00013	989953	383751	1/23/2021	19.96
	PCard JE	00013	989953	383751	1/23/2021	85.29
	PCard JE	00013	989953	383751	1/23/2021	657.37
	PCard JE	00013	989953	383751	1/23/2021	4.82

**County of Adams**  
**Vendor Payment Report**

<u>3031</u>	<u>PW - Operations &amp; Maintenance</u>	<u>Fund</u>	<u>Voucher</u>	<u>Batch No</u>	<u>GL Date</u>	<u>Amount</u>
	PCard JE	00013	989953	383751	1/23/2021	33.07
	PCard JE	00013	989953	383751	1/23/2021	56.99
	PCard JE	00013	989953	383751	1/23/2021	21.89
					Account Total	1,628.28
	Other Communications					
	PCard JE	00013	989953	383751	1/23/2021	101.05
					Account Total	101.05
	Pothole Asphalt					
	PCard JE	00013	989953	383751	1/23/2021	136.32
	PCard JE	00013	989953	383751	1/23/2021	111.76
	PCard JE	00013	989953	383751	1/23/2021	139.44
					Account Total	387.52
	Printing External					
	PCard JE	00013	989953	383751	1/23/2021	69.96
					Account Total	69.96
	Repair & Maint Supplies					
	PCard JE	00013	989953	383751	1/23/2021	127.90
	PCard JE	00013	989953	383751	1/23/2021	173.08
	PCard JE	00013	989953	383751	1/23/2021	44.37
	PCard JE	00013	989953	383751	1/23/2021	984.94
	PCard JE	00013	989953	383751	1/23/2021	80.99
	PCard JE	00013	989953	383751	1/23/2021	114.89
	PCard JE	00013	989953	383751	1/23/2021	107.10
	PCard JE	00013	989953	383751	1/23/2021	38.50
					Account Total	1,671.77
	Road Oil					
	COBITCO INC	00013	989766	383564	2/1/2021	108.90
					Account Total	108.90
	Traffic Signal Maintenance					
	CITY OF THORNTON UTILITIES	00013	989765	383564	2/1/2021	4,045.51
	UTILITY NOTIFICATION CENTER OF	00013	989771	383564	2/1/2021	138.57
					Account Total	4,184.08
	Uniforms & Cleaning					
	PCard JE	00013	989953	383751	1/23/2021	39.97

**County of Adams**  
**Vendor Payment Report**

<u>3031</u>	<u>PW - Operations &amp; Maintenance</u>	<u>Fund</u>	<u>Voucher</u>	<u>Batch No</u>	<u>GL Date</u>	<u>Amount</u>
					Account Total	39.97
	Water/Sewer/Sanitation					
	PCard JE	00013	989953	383751	1/23/2021	292.37
	PREMIER PORTABLES	00013	989770	383564	2/1/2021	350.00
					Account Total	642.37
					Department Total	<u>43,597.55</u>

**County of Adams**  
**Vendor Payment Report**

<u>1037</u>	<u>PW - Regional Transportation</u>	<u>Fund</u>	<u>Voucher</u>	<u>Batch No</u>	<u>GL Date</u>	<u>Amount</u>
	Other Communications					
	PCard JE	00001	989953	383751	1/23/2021	<u>81.70</u>
					Account Total	<u>81.70</u>
					Department Total	<u><u>81.70</u></u>

**County of Adams**  
**Vendor Payment Report**

<u>97755</u>	<u>Recover CO Program</u>	<u>Fund</u>	<u>Voucher</u>	<u>Batch No</u>	<u>GL Date</u>	<u>Amount</u>
	Clnt Trng-Tuition					
	PCard JE	00035	989953	383751	1/23/2021	5,000.00
	PCard JE	00035	989953	383751	1/23/2021	4,580.00
	PCard JE	00035	989953	383751	1/23/2021	4,988.00
					Account Total	<u>14,568.00</u>
					Department Total	<u><u>14,568.00</u></u>

**County of Adams**  
**Vendor Payment Report**

<u>13</u>	<u>Road &amp; Bridge Fund</u>	<u>Fund</u>	<u>Voucher</u>	<u>Batch No</u>	<u>GL Date</u>	<u>Amount</u>
	Received not Vouchered Clrg					
	DESIGN WORKSHOP	00013	990031	383900	2/4/2021	18,794.46
	HCL ENGINEERING & SURVEYING LL	00013	990028	383900	2/4/2021	14,620.00
	HDR ENGINEERING INC	00013	990034	383900	2/4/2021	3,500.00
					Account Total	<u>36,914.46</u>
					Department Total	<u><u>36,914.46</u></u>

**County of Adams**  
**Vendor Payment Report**

<u>2004</u>	<u>Sheriff Training</u>	<u>Fund</u>	<u>Voucher</u>	<u>Batch No</u>	<u>GL Date</u>	<u>Amount</u>
	Business Meetings					
	PCard JE	00001	989953	383751	1/23/2021	35.07
	PCard JE	00001	989953	383751	1/23/2021	174.62
					Account Total	209.69
	Membership Dues					
	PCard JE	00001	989953	383751	1/23/2021	190.00
					Account Total	190.00
	Operating Supplies					
	PCard JE	00001	989953	383751	1/23/2021	86.87
	PCard JE	00001	989953	383751	1/23/2021	1,181.30
	PCard JE	00001	989953	383751	1/23/2021	1,025.00
	PCard JE	00001	989953	383751	1/23/2021	25.96
	PCard JE	00001	989953	383751	1/23/2021	147.60
	PCard JE	00001	989953	383751	1/23/2021	577.15
					Account Total	3,043.88
	Other Professional Serv					
	PCard JE	00001	989953	383751	1/23/2021	118.99
	PCard JE	00001	989953	383751	1/23/2021	2,212.00
	PCard JE	00001	989953	383751	1/23/2021	118.50
	PCard JE	00001	989953	383751	1/23/2021	90.41
					Account Total	2,539.90
	Printing External					
	PCard JE	00001	989953	383751	1/23/2021	349.98
					Account Total	349.98
	Subscrip/Publications					
	PCard JE	00001	989953	383751	1/23/2021	66.50
					Account Total	66.50
	Uniforms & Cleaning					
	GALLS LLC	00001	989891	383671	2/2/2021	397.98
					Account Total	397.98
					Department Total	6,797.93

**County of Adams**  
**Vendor Payment Report**

<u>2008</u>	<u>SHF - Training Academy</u>	<u>Fund</u>	<u>Voucher</u>	<u>Batch No</u>	<u>GL Date</u>	<u>Amount</u>
	Uniforms & Cleaning					
	PCard JE	00001	989953	383751	1/23/2021	48.16
	PCard JE	00001	989953	383751	1/23/2021	348.00
	PCard JE	00001	989953	383751	1/23/2021	1,237.64
					Account Total	<u>1,633.80</u>
					Department Total	<u><u>1,633.80</u></u>





**County of Adams**  
**Vendor Payment Report**

<u>2011</u>	<u>SHF- Admin Services Division</u>	<u>Fund</u>	<u>Voucher</u>	<u>Batch No</u>	<u>GL Date</u>	<u>Amount</u>
	PCard JE	00001	989953	383751	1/23/2021	10.00
	PCard JE	00001	989953	383751	1/23/2021	10.00
	PCard JE	00001	989953	383751	1/23/2021	10.00
	PCard JE	00001	989953	383751	1/23/2021	10.00
	PCard JE	00001	989953	383751	1/23/2021	10.00
	PCard JE	00001	989953	383751	1/23/2021	10.00
	PCard JE	00001	989953	383751	1/23/2021	10.00
	PCard JE	00001	989953	383751	1/23/2021	10.00
	PCard JE	00001	989953	383751	1/23/2021	10.00
	PCard JE	00001	989953	383751	1/23/2021	10.00
	PCard JE	00001	989953	383751	1/23/2021	10.00
	PCard JE	00001	989953	383751	1/23/2021	10.00
	PCard JE	00001	989953	383751	1/23/2021	10.00
	PCard JE	00001	989953	383751	1/23/2021	9.00
	PCard JE	00001	989953	383751	1/23/2021	9.00
	PCard JE	00001	989953	383751	1/23/2021	10.00
	PCard JE	00001	989953	383751	1/23/2021	3.00
	PCard JE	00001	989953	383751	1/23/2021	3.00
	PCard JE	00001	989953	383751	1/23/2021	3.00
	PCard JE	00001	989953	383751	1/23/2021	3.00
	PCard JE	00001	989953	383751	1/23/2021	3.00
	PCard JE	00001	989953	383751	1/23/2021	5.62
	PCard JE	00001	989953	383751	1/23/2021	6.00
	PCard JE	00001	989953	383751	1/23/2021	9.00
	PCard JE	00001	989953	383751	1/23/2021	9.00
	PCard JE	00001	989953	383751	1/23/2021	9.00
	PCard JE	00001	989953	383751	1/23/2021	24.95
	PCard JE	00001	989953	383751	1/23/2021	24.95-
	PCard JE	00001	989953	383751	1/23/2021	24.95-
	PCard JE	00001	989953	383751	1/23/2021	24.95-
	PCard JE	00001	989953	383751	1/23/2021	24.95-
	PCard JE	00001	989953	383751	1/23/2021	3.00
	PCard JE	00001	989953	383751	1/23/2021	3.00
	PCard JE	00001	989953	383751	1/23/2021	15.00
	PCard JE	00001	989953	383751	1/23/2021	15.00
	PCard JE	00001	989953	383751	1/23/2021	9.00
	PCard JE	00001	989953	383751	1/23/2021	9.00
	PCard JE	00001	989953	383751	1/23/2021	9.00

**County of Adams**  
**Vendor Payment Report**

<u>2011</u>	<u>SHF- Admin Services Division</u>	<u>Fund</u>	<u>Voucher</u>	<u>Batch No</u>	<u>GL Date</u>	<u>Amount</u>
	PCard JE	00001	989953	383751	1/23/2021	9.00
	PCard JE	00001	989953	383751	1/23/2021	3.00
	PCard JE	00001	989953	383751	1/23/2021	3.00
	PCard JE	00001	989953	383751	1/23/2021	12.00
	PCard JE	00001	989953	383751	1/23/2021	10.00
	PCard JE	00001	989953	383751	1/23/2021	12.00
	PCard JE	00001	989953	383751	1/23/2021	10.00
	PCard JE	00001	989953	383751	1/23/2021	10.00
	PCard JE	00001	989953	383751	1/23/2021	3.00
	PCard JE	00001	989953	383751	1/23/2021	9.00
	PCard JE	00001	989953	383751	1/23/2021	9.00
	PCard JE	00001	989953	383751	1/23/2021	10.00
	PCard JE	00001	989953	383751	1/23/2021	12.00
					Account Total	587.77
	Concealed Handgun Permit Fees					
	TOMCZAK MICHAEL E	00001	989934	383686	2/2/2021	50.00
					Account Total	50.00
	Consultant Services					
	PCard JE	00001	989953	383751	1/23/2021	267.25
					Account Total	267.25
	Education & Training					
	PCard JE	00001	989953	383751	1/23/2021	350.00
	PCard JE	00001	989953	383751	1/23/2021	350.00
	PCard JE	00001	989953	383751	1/23/2021	1,254.00
	PCard JE	00001	989953	383751	1/23/2021	1,850.00-
	PCard JE	00001	989953	383751	1/23/2021	695.00
					Account Total	799.00
	Membership Dues					
	COLO MOUNTED LAW ENFORCEMENT A	00001	989931	383686	2/2/2021	50.00
					Account Total	50.00
	Minor Equipment					
	PCard JE	00001	989953	383751	1/23/2021	563.98
					Account Total	563.98
	Operating Supplies					

**County of Adams**  
**Vendor Payment Report**

<u>2011</u>	<u>SHF- Admin Services Division</u>	<u>Fund</u>	<u>Voucher</u>	<u>Batch No</u>	<u>GL Date</u>	<u>Amount</u>
	PCard JE	00001	989953	383751	1/23/2021	15.05
	PCard JE	00001	989953	383751	1/23/2021	50.43
	PCard JE	00001	989953	383751	1/23/2021	169.40
	PCard JE	00001	989953	383751	1/23/2021	190.80
	PCard JE	00001	989953	383751	1/23/2021	1,000.00
	PCard JE	00001	989953	383751	1/23/2021	38.75
	PCard JE	00001	989953	383751	1/23/2021	118.63
	PCard JE	00001	989953	383751	1/23/2021	69.47
	PCard JE	00001	989953	383751	1/23/2021	319.07
	PCard JE	00001	989953	383751	1/23/2021	271.11
	PCard JE	00001	989953	383751	1/23/2021	704.98
	PCard JE	00001	989953	383751	1/23/2021	16.76
	PCard JE	00001	989953	383751	1/23/2021	186.93
	PCard JE	00001	989953	383751	1/23/2021	25.98
	PCard JE	00001	989953	383751	1/23/2021	10.65
	PCard JE	00001	989953	383751	1/23/2021	159.95
	PCard JE	00001	989953	383751	1/23/2021	123.42
	PCard JE	00001	989953	383751	1/23/2021	277.60
	PCard JE	00001	989953	383751	1/23/2021	359.90
	PCard JE	00001	989953	383751	1/23/2021	4.75
	PCard JE	00001	989953	383751	1/23/2021	18.39
	PCard JE	00001	989953	383751	1/23/2021	1,273.50
	PCard JE	00001	989953	383751	1/23/2021	22.99
	PCard JE	00001	989953	383751	1/23/2021	1,784.85
					Account Total	7,213.36
	Other Communications					
	PCard JE	00001	989953	383751	1/23/2021	377.85
					Account Total	377.85
	Other Professional Serv					
	PSYCHOLOGICAL DIMENSIONS	00001	989932	383686	2/2/2021	6,450.00
					Account Total	6,450.00
	Special Events					
	PCard JE	00001	989953	383751	1/23/2021	1,087.42-
	PCard JE	00001	989953	383751	1/23/2021	165.94
					Account Total	921.48-

**County of Adams**  
**Vendor Payment Report**

<u>2011</u>	<u>SHF- Admin Services Division</u>	<u>Fund</u>	<u>Voucher</u>	<u>Batch No</u>	<u>GL Date</u>	<u>Amount</u>
	Travel & Transportation					
	PCard JE	00001	989953	383751	1/23/2021	283.96
	PCard JE	00001	989953	383751	1/23/2021	721.22
					Account Total	<u>1,005.18</u>
	Uniforms & Cleaning					
	GALLS LLC	00001	989892	383671	2/2/2021	622.47
	GALLS LLC	00001	989901	383671	2/2/2021	1,838.69
	PCard JE	00001	989953	383751	1/23/2021	199.90
					Account Total	<u>2,661.06</u>
					Department Total	<u><u>19,950.08</u></u>

**County of Adams**  
**Vendor Payment Report**

<u>2015</u>	<u>SHF- Civil Section</u>	<u>Fund</u>	<u>Voucher</u>	<u>Batch No</u>	<u>GL Date</u>	<u>Amount</u>
	Operating Supplies					
	PCard JE	00001	989953	383751	1/23/2021	32.00
					Account Total	32.00
	Sheriff's Fees					
	ALTITUDE COMMUNITY LAW	00001	989739	383473	1/29/2021	19.00
	CARRILLO ORTIZ JONATHAN	00001	989755	383473	1/29/2021	32.00
	CORAK NEVEN	00001	989759	383473	1/29/2021	66.00
	ELLIOTT LEGAL INVESTIGATIONS	00001	989745	383473	1/29/2021	19.00
	FRANCY LAW FIRM	00001	989742	383473	1/29/2021	19.00
	FRANCY LAW FIRM	00001	989743	383473	1/29/2021	19.00
	FRANCY LAW FIRM	00001	989744	383473	1/29/2021	19.00
	FRANK J BALL	00001	989738	383473	1/29/2021	19.00
	GARCIA EMMA CHRISTINE	00001	989758	383473	1/29/2021	49.00
	GPS SERVERS LLC	00001	989750	383473	1/29/2021	43.00
	HOLST AND BOETTCHER	00001	989741	383473	1/29/2021	19.00
	LAW OFFICES OF BRANDON CEGLIAN	00001	989747	383473	1/29/2021	19.00
	LAW OFFICES OF BRANDON CEGLIAN	00001	989748	383473	1/29/2021	19.00
	NELSON AND KENNARD	00001	989737	383473	1/29/2021	19.00
	NGUYEN NANCY	00001	989757	383473	1/29/2021	19.00
	OLIVER JO MARIE	00001	989740	383473	1/29/2021	66.00
	PAPPAS JIM GEORGE	00001	989760	383473	1/29/2021	66.00
	PATTON AND DAVIDSON	00001	989749	383473	1/29/2021	173.00
	THOMPSON BRODY AND KAPLAN	00001	989756	383473	1/29/2021	56.00
	TRUJILLO ALEJANDRO R	00001	989753	383473	1/29/2021	19.00
	ZHANG XIONG WEN	00001	989754	383473	1/29/2021	19.00
	ZHOU QUANYI	00001	989752	383473	1/29/2021	19.00
					Account Total	817.00
					Department Total	849.00

**County of Adams**  
**Vendor Payment Report**

<u>2075</u>	<u>SHF- Commissary Fund</u>	<u>Fund</u>	<u>Voucher</u>	<u>Batch No</u>	<u>GL Date</u>	<u>Amount</u>
	Licenses and Fees					
	PCard JE	00001	989953	383751	1/23/2021	1,608.88
					Account Total	1,608.88
	Operating Supplies					
	PCard JE	00001	989953	383751	1/23/2021	160.80
	PCard JE	00001	989953	383751	1/23/2021	616.00
	PCard JE	00001	989953	383751	1/23/2021	41.74
					Account Total	818.54
					Department Total	2,427.42

**County of Adams**  
**Vendor Payment Report**

<u>2016</u>	<u>SHF- Detective Division</u>	<u>Fund</u>	<u>Voucher</u>	<u>Batch No</u>	<u>GL Date</u>	<u>Amount</u>
	Education & Training					
	PCard JE	00001	989953	383751	1/23/2021	655.00
	PCard JE	00001	989953	383751	1/23/2021	199.00
					Account Total	854.00
	Equipment Rental					
	PCard JE	00001	989953	383751	1/23/2021	411.56
					Account Total	411.56
	Membership Dues					
	PCard JE	00001	989953	383751	1/23/2021	65.00
					Account Total	65.00
	Minor Equipment					
	PCard JE	00001	989953	383751	1/23/2021	1,496.95
					Account Total	1,496.95
	Operating Supplies					
	PCard JE	00001	989953	383751	1/23/2021	25.98
	PCard JE	00001	989953	383751	1/23/2021	651.50-
	PCard JE	00001	989953	383751	1/23/2021	100.00
	PCard JE	00001	989953	383751	1/23/2021	86.22
	PCard JE	00001	989953	383751	1/23/2021	55.99
	PCard JE	00001	989953	383751	1/23/2021	359.37
	PCard JE	00001	989953	383751	1/23/2021	159.92
	PCard JE	00001	989953	383751	1/23/2021	194.95
	PCard JE	00001	989953	383751	1/23/2021	824.95
	PCard JE	00001	989953	383751	1/23/2021	328.70
	PCard JE	00001	989953	383751	1/23/2021	5.00
	PCard JE	00001	989953	383751	1/23/2021	101.38-
	PCard JE	00001	989953	383751	1/23/2021	101.38
	PCard JE	00001	989953	383751	1/23/2021	25.16
	PCard JE	00001	989953	383751	1/23/2021	10.00
	PCard JE	00001	989953	383751	1/23/2021	61.50
	PCard JE	00001	989953	383751	1/23/2021	7.88
	PCard JE	00001	989953	383751	1/23/2021	274.54
	PCard JE	00001	989953	383751	1/23/2021	904.15
	PCard JE	00001	989953	383751	1/23/2021	1,643.27



**County of Adams**  
**Vendor Payment Report**

<u>2016</u>	<u>SHF- Detective Division</u>	<u>Fund</u>	<u>Voucher</u>	<u>Batch No</u>	<u>GL Date</u>	<u>Amount</u>
	PCard JE	00001	989953	383751	1/23/2021	76.70
	PCard JE	00001	989953	383751	1/23/2021	332.81
	PCard JE	00001	989953	383751	1/23/2021	10.87
	PCard JE	00001	989953	383751	1/23/2021	485.02
	PCard JE	00001	989953	383751	1/23/2021	135.01
	PCard JE	00001	989953	383751	1/23/2021	324.82
	PCard JE	00001	989953	383751	1/23/2021	116.80
	PCard JE	00001	989953	383751	1/23/2021	62.90
	PCard JE	00001	989953	383751	1/23/2021	69.99
	PCard JE	00001	989953	383751	1/23/2021	118.62
	PCard JE	00001	989953	383751	1/23/2021	787.22
	PCard JE	00001	989953	383751	1/23/2021	283.86
	PCard JE	00001	989953	383751	1/23/2021	69.50
	PCard JE	00001	989953	383751	1/23/2021	54.95
	PCard JE	00001	989953	383751	1/23/2021	18.70
	PCard JE	00001	989953	383751	1/23/2021	50.30
	PCard JE	00001	989953	383751	1/23/2021	10.00
	PCard JE	00001	989953	383751	1/23/2021	304.92
					Account Total	7,729.07
	Other Professional Serv					
	PCard JE	00001	989953	383751	1/23/2021	246.00
	PCard JE	00001	989953	383751	1/23/2021	30.00
					Account Total	276.00
	Printing External					
	PCard JE	00001	989953	383751	1/23/2021	49.98
					Account Total	49.98
	Uniforms & Cleaning					
	GALLS LLC	00001	989893	383671	2/2/2021	275.64
	GALLS LLC	00001	989900	383671	2/2/2021	139.97
					Account Total	415.61
					Department Total	11,298.17

**County of Adams**  
**Vendor Payment Report**

<u>2071</u>	<u>SHF- Detention Facility</u>	<u>Fund</u>	<u>Voucher</u>	<u>Batch No</u>	<u>GL Date</u>	<u>Amount</u>
	Car Washes					
	PCard JE	00001	989953	383751	1/23/2021	6.00
	PCard JE	00001	989953	383751	1/23/2021	3.00
	PCard JE	00001	989953	383751	1/23/2021	6.00
	PCard JE	00001	989953	383751	1/23/2021	3.00
	PCard JE	00001	989953	383751	1/23/2021	6.00
	PCard JE	00001	989953	383751	1/23/2021	3.00
	PCard JE	00001	989953	383751	1/23/2021	6.00
	PCard JE	00001	989953	383751	1/23/2021	3.00
	PCard JE	00001	989953	383751	1/23/2021	3.00
	PCard JE	00001	989953	383751	1/23/2021	3.00
	PCard JE	00001	989953	383751	1/23/2021	3.00
	PCard JE	00001	989953	383751	1/23/2021	10.00
					Account Total	61.00
	Education & Training					
	PCard JE	00001	989953	383751	1/23/2021	10.00
	PCard JE	00001	989953	383751	1/23/2021	98.56
	PCard JE	00001	989953	383751	1/23/2021	199.00
	PCard JE	00001	989953	383751	1/23/2021	895.00
	PCard JE	00001	989953	383751	1/23/2021	97.00
	PCard JE	00001	989953	383751	1/23/2021	97.00
					Account Total	1,202.56
	Maintenance Contracts					
	PCard JE	00001	989953	383751	1/23/2021	1,907.60
					Account Total	1,907.60
	Membership Dues					
	PCard JE	00001	989953	383751	1/23/2021	105.00
					Account Total	105.00
	Operating Supplies					
	PCard JE	00001	989953	383751	1/23/2021	203.00
	PCard JE	00001	989953	383751	1/23/2021	129.06
	PCard JE	00001	989953	383751	1/23/2021	270.00
	PCard JE	00001	989953	383751	1/23/2021	50.00

**County of Adams**  
**Vendor Payment Report**

<u>2071</u>	<u>SHF- Detention Facility</u>	<u>Fund</u>	<u>Voucher</u>	<u>Batch No</u>	<u>GL Date</u>	<u>Amount</u>
	PCard JE	00001	989953	383751	1/23/2021	17.99
	PCard JE	00001	989953	383751	1/23/2021	43.85
	PCard JE	00001	989953	383751	1/23/2021	146.20
	PCard JE	00001	989953	383751	1/23/2021	1,989.40
	PCard JE	00001	989953	383751	1/23/2021	21.95
	PCard JE	00001	989953	383751	1/23/2021	253.77
	PCard JE	00001	989953	383751	1/23/2021	897.33
	PCard JE	00001	989953	383751	1/23/2021	149.99
	PCard JE	00001	989953	383751	1/23/2021	118.78
	PCard JE	00001	989953	383751	1/23/2021	241.18
	PCard JE	00001	989953	383751	1/23/2021	71.18
	PCard JE	00001	989953	383751	1/23/2021	1,171.30
	PCard JE	00001	989953	383751	1/23/2021	1,636.00
	PCard JE	00001	989953	383751	1/23/2021	285.71-
	PCard JE	00001	989953	383751	1/23/2021	9.30
	PCard JE	00001	989953	383751	1/23/2021	10.85
	PCard JE	00001	989953	383751	1/23/2021	30.63
	PCard JE	00001	989953	383751	1/23/2021	74.95
	PCard JE	00001	989953	383751	1/23/2021	184.85
	PCard JE	00001	989953	383751	1/23/2021	3,422.00
	PCard JE	00001	989953	383751	1/23/2021	635.44
	PCard JE	00001	989953	383751	1/23/2021	138.33
	PCard JE	00001	989953	383751	1/23/2021	80.70
	PCard JE	00001	989953	383751	1/23/2021	76.67
	PCard JE	00001	989953	383751	1/23/2021	798.12
	SUMMIT FOOD SERVICE LLC	00001	989933	383686	2/2/2021	7,185.48
					Account Total	19,772.59
	Other Repair & Maint					
	KD SERVICE GROUP	00001	989916	383671	2/2/2021	20,151.63
	KD SERVICE GROUP	00001	989918	383671	2/2/2021	371.88
	KD SERVICE GROUP	00001	989919	383671	2/2/2021	3,815.29
	KD SERVICE GROUP	00001	989921	383671	2/2/2021	706.14
	KD SERVICE GROUP	00001	989922	383671	2/2/2021	292.76
	KD SERVICE GROUP	00001	989923	383671	2/2/2021	417.07
					Account Total	25,754.77

**County of Adams**  
**Vendor Payment Report**

<u>2071</u>	<u>SHF- Detention Facility</u>	<u>Fund</u>	<u>Voucher</u>	<u>Batch No</u>	<u>GL Date</u>	<u>Amount</u>
	Printing External					
	PCard JE	00001	989953	383751	1/23/2021	1,166.90
					Account Total	1,166.90
	Repair & Maint Supplies					
	PCard JE	00001	989953	383751	1/23/2021	846.00
					Account Total	846.00
	Travel & Transportation					
	PCard JE	00001	989953	383751	1/23/2021	36.26
					Account Total	36.26
	Uniforms & Cleaning					
	GALLS LLC	00001	989894	383671	2/2/2021	264.98
	GALLS LLC	00001	989896	383671	2/2/2021	4,982.84
	GALLS LLC	00001	989897	383671	2/2/2021	133.85
	GALLS LLC	00001	989898	383671	2/2/2021	104.99
	GALLS LLC	00001	989899	383671	2/2/2021	1,609.50
	GALLS LLC	00001	989900	383671	2/2/2021	306.81
	PCard JE	00001	989953	383751	1/23/2021	1,887.75
					Account Total	9,290.72
					Department Total	60,143.40

**County of Adams**  
**Vendor Payment Report**

<u>2010</u>	<u>SHF- MIS Unit</u>	<u>Fund</u>	<u>Voucher</u>	<u>Batch No</u>	<u>GL Date</u>	<u>Amount</u>
	Computers					
	PCard JE	00001	989953	383751	1/23/2021	2,712.00
	PCard JE	00001	989953	383751	1/23/2021	419.50
	PCard JE	00001	989953	383751	1/23/2021	2,385.00
					Account Total	5,516.50
	Maintenance Contracts					
	PCard JE	00001	989953	383751	1/23/2021	3,145.66
	PCard JE	00001	989953	383751	1/23/2021	94.32
					Account Total	3,239.98
	Other Communications					
	PCard JE	00001	989953	383751	1/23/2021	90.95
					Account Total	90.95
	Software and Licensing					
	PCard JE	00001	989953	383751	1/23/2021	228.82
					Account Total	228.82
	Subscrip/Publications					
	PCard JE	00001	989953	383751	1/23/2021	39.63
	PCard JE	00001	989953	383751	1/23/2021	539.71
					Account Total	579.34
					Department Total	9,655.59

**County of Adams**  
**Vendor Payment Report**

<u>2017</u>	<u>SHF- Patrol Division</u>	<u>Fund</u>	<u>Voucher</u>	<u>Batch No</u>	<u>GL Date</u>	<u>Amount</u>
	Business Meetings					
	PCard JE	00001	989953	383751	1/23/2021	34.46
	PCard JE	00001	989953	383751	1/23/2021	235.23
					Account Total	269.69
	Car Washes					
	PCard JE	00001	989953	383751	1/23/2021	7.00
	PCard JE	00001	989953	383751	1/23/2021	9.00
	PCard JE	00001	989953	383751	1/23/2021	8.00
					Account Total	24.00
	Education & Training					
	PCard JE	00001	989953	383751	1/23/2021	399.00
	PCard JE	00001	989953	383751	1/23/2021	199.00
	PCard JE	00001	989953	383751	1/23/2021	405.00
	PCard JE	00001	989953	383751	1/23/2021	200.00
					Account Total	1,203.00
	Fuel, Gas & Oil					
	PCard JE	00001	989953	383751	1/23/2021	80.55
					Account Total	80.55
	Medical Services					
	PCard JE	00001	989953	383751	1/23/2021	1,157.91
	PCard JE	00001	989953	383751	1/23/2021	60.95
	PCard JE	00001	989953	383751	1/23/2021	114.30
					Account Total	1,333.16
	Membership Dues					
	PCard JE	00001	989953	383751	1/23/2021	50.00
	PCard JE	00001	989953	383751	1/23/2021	450.00
	PCard JE	00001	989953	383751	1/23/2021	400.00
					Account Total	900.00
	Office Furniture					
	PCard JE	00001	989953	383751	1/23/2021	479.94
	PCard JE	00001	989953	383751	1/23/2021	359.98
					Account Total	839.92
	Operating Supplies					

**County of Adams**  
**Vendor Payment Report**

<u>2017</u>	<u>SHF- Patrol Division</u>	<u>Fund</u>	<u>Voucher</u>	<u>Batch No</u>	<u>GL Date</u>	<u>Amount</u>
	PCard JE	00001	989953	383751	1/23/2021	121.64
	PCard JE	00001	989953	383751	1/23/2021	1,655.76
	PCard JE	00001	989953	383751	1/23/2021	1,901.00
	PCard JE	00001	989953	383751	1/23/2021	229.62
	PCard JE	00001	989953	383751	1/23/2021	698.75
	PCard JE	00001	989953	383751	1/23/2021	100.10
	PCard JE	00001	989953	383751	1/23/2021	38.99
	PCard JE	00001	989953	383751	1/23/2021	1,737.84
	PCard JE	00001	989953	383751	1/23/2021	17.49
	PCard JE	00001	989953	383751	1/23/2021	13.58
	PCard JE	00001	989953	383751	1/23/2021	15.99
	PCard JE	00001	989953	383751	1/23/2021	19.90
	PCard JE	00001	989953	383751	1/23/2021	39.40
	PCard JE	00001	989953	383751	1/23/2021	214.37
	PCard JE	00001	989953	383751	1/23/2021	56.31
	PCard JE	00001	989953	383751	1/23/2021	226.41
	PCard JE	00001	989953	383751	1/23/2021	233.02
	PCard JE	00001	989953	383751	1/23/2021	144.97
	PCard JE	00001	989953	383751	1/23/2021	73.00
	PCard JE	00001	989953	383751	1/23/2021	129.19
	PCard JE	00001	989953	383751	1/23/2021	95.97
	PCard JE	00001	989953	383751	1/23/2021	48.52
	PCard JE	00001	989953	383751	1/23/2021	436.11
	PCard JE	00001	989953	383751	1/23/2021	19.98
	PCard JE	00001	989953	383751	1/23/2021	432.00
	PCard JE	00001	989953	383751	1/23/2021	305.74
	PCard JE	00001	989953	383751	1/23/2021	54.72
	PCard JE	00001	989953	383751	1/23/2021	84.88
	PCard JE	00001	989953	383751	1/23/2021	71.98
	PCard JE	00001	989953	383751	1/23/2021	92.60
	PCard JE	00001	989953	383751	1/23/2021	289.00
	PCard JE	00001	989953	383751	1/23/2021	149.70
	PCard JE	00001	989953	383751	1/23/2021	4.66
	PCard JE	00001	989953	383751	1/23/2021	9.32
	PCard JE	00001	989953	383751	1/23/2021	57.98
	PCard JE	00001	989953	383751	1/23/2021	28.65

**County of Adams**  
**Vendor Payment Report**

<u>2017</u>	<u>SHF- Patrol Division</u>	<u>Fund</u>	<u>Voucher</u>	<u>Batch No</u>	<u>GL Date</u>	<u>Amount</u>
	PCard JE	00001	989953	383751	1/23/2021	189.80
					Account Total	10,038.94
	Other Communications					
	PCard JE	00001	989953	383751	1/23/2021	1.05
	PCard JE	00001	989953	383751	1/23/2021	110.13
					Account Total	111.18
	Other Professional Serv					
	PCard JE	00001	989953	383751	1/23/2021	30.00
					Account Total	30.00
	Uniforms & Cleaning					
	GALLS LLC	00001	989889	383671	2/2/2021	292.24
	PCard JE	00001	989953	383751	1/23/2021	1,057.10
	PCard JE	00001	989953	383751	1/23/2021	1,831.72
	PCard JE	00001	989953	383751	1/23/2021	61.26
	PCard JE	00001	989953	383751	1/23/2021	16.46
	PCard JE	00001	989953	383751	1/23/2021	4,616.31
	PCard JE	00001	989953	383751	1/23/2021	2,288.00
					Account Total	10,163.09
	Vehicle Repair & Maint					
	PCard JE	00001	989953	383751	1/23/2021	205.00
					Account Total	205.00
					Department Total	25,198.53



**County of Adams**  
**Vendor Payment Report**

<u>2018</u>	<u>SHF- Records/Warrants Section</u>	<u>Fund</u>	<u>Voucher</u>	<u>Batch No</u>	<u>GL Date</u>	<u>Amount</u>
	Extraditions					
	PCard JE	00001	989953	383751	1/23/2021	39.38
	PCard JE	00001	989953	383751	1/23/2021	79.38
	PCard JE	00001	989953	383751	1/23/2021	13.30
	PCard JE	00001	989953	383751	1/23/2021	13.30
	PCard JE	00001	989953	383751	1/23/2021	386.10
	PCard JE	00001	989953	383751	1/23/2021	173.40
	PCard JE	00001	989953	383751	1/23/2021	96.20
	PCard JE	00001	989953	383751	1/23/2021	96.20
	PCard JE	00001	989953	383751	1/23/2021	48.10
	PCard JE	00001	989953	383751	1/23/2021	572.40
	PCard JE	00001	989953	383751	1/23/2021	501.20
	PCard JE	00001	989953	383751	1/23/2021	292.90
	PCard JE	00001	989953	383751	1/23/2021	324.52
	PCard JE	00001	989953	383751	1/23/2021	304.80
	PCard JE	00001	989953	383751	1/23/2021	304.80
	PCard JE	00001	989953	383751	1/23/2021	87.40
	PCard JE	00001	989953	383751	1/23/2021	104.80
	PCard JE	00001	989953	383751	1/23/2021	104.80
	PCard JE	00001	989953	383751	1/23/2021	52.40
	PCard JE	00001	989953	383751	1/23/2021	138.58
	PCard JE	00001	989953	383751	1/23/2021	96.80
	PCard JE	00001	989953	383751	1/23/2021	96.80
	PCard JE	00001	989953	383751	1/23/2021	48.40
	PCard JE	00001	989953	383751	1/23/2021	572.40
	PCard JE	00001	989953	383751	1/23/2021	220.90
	PCard JE	00001	989953	383751	1/23/2021	216.20
	PCard JE	00001	989953	383751	1/23/2021	216.20
	PCard JE	00001	989953	383751	1/23/2021	158.10
	PCard JE	00001	989953	383751	1/23/2021	123.20
	PCard JE	00001	989953	383751	1/23/2021	123.20
	PCard JE	00001	989953	383751	1/23/2021	35.10
	PCard JE	00001	989953	383751	1/23/2021	170.00
	PCard JE	00001	989953	383751	1/23/2021	306.20
	PCard JE	00001	989953	383751	1/23/2021	339.92
	PCard JE	00001	989953	383751	1/23/2021	241.98

**County of Adams**  
**Vendor Payment Report**

<u>2018</u>	<u>SHF- Records/Warrants Section</u>	<u>Fund</u>	<u>Voucher</u>	<u>Batch No</u>	<u>GL Date</u>	<u>Amount</u>
	PCard JE	00001	989953	383751	1/23/2021	710.40
	PCard JE	00001	989953	383751	1/23/2021	710.40
	PCard JE	00001	989953	383751	1/23/2021	325.20
	PCard JE	00001	989953	383751	1/23/2021	198.80
	PCard JE	00001	989953	383751	1/23/2021	198.80
	PCard JE	00001	989953	383751	1/23/2021	146.40
	PCard JE	00001	989953	383751	1/23/2021	82.80
	PCard JE	00001	989953	383751	1/23/2021	195.66
	PCard JE	00001	989953	383751	1/23/2021	290.86
	PCard JE	00001	989953	383751	1/23/2021	216.80
	PCard JE	00001	989953	383751	1/23/2021	216.80
	PCard JE	00001	989953	383751	1/23/2021	108.40
	PCard JE	00001	989953	383751	1/23/2021	256.24
	PCard JE	00001	989953	383751	1/23/2021	339.92
					Account Total	10,696.84
	Operating Supplies					
	PCard JE	00001	989953	383751	1/23/2021	897.39
	PCard JE	00001	989953	383751	1/23/2021	62.38
	PCard JE	00001	989953	383751	1/23/2021	144.28
	PCard JE	00001	989953	383751	1/23/2021	120.60
	PCard JE	00001	989953	383751	1/23/2021	438.63
					Account Total	1,663.28
	Other Professional Serv					
	PCard JE	00001	989953	383751	1/23/2021	69.08
	PCard JE	00001	989953	383751	1/23/2021	48.75
					Account Total	117.83
					Department Total	12,477.95

**County of Adams**  
**Vendor Payment Report**

<u>2005</u>	<u>SHF- TAC Section</u>	<u>Fund</u>	<u>Voucher</u>	<u>Batch No</u>	<u>GL Date</u>	<u>Amount</u>
	Books					
	PCard JE	00001	989953	383751	1/23/2021	1,023.36
					Account Total	1,023.36
	Membership Dues					
	PCard JE	00001	989953	383751	1/23/2021	40.00
	PCard JE	00001	989953	383751	1/23/2021	40.00
	PCard JE	00001	989953	383751	1/23/2021	40.00
	PCard JE	00001	989953	383751	1/23/2021	40.00
	PCard JE	00001	989953	383751	1/23/2021	40.00
	PCard JE	00001	989953	383751	1/23/2021	40.00
					Account Total	280.00
	Operating Supplies					
	PCard JE	00001	989953	383751	1/23/2021	178.74
	PCard JE	00001	989953	383751	1/23/2021	115.82
	PCard JE	00001	989953	383751	1/23/2021	36.99
	PCard JE	00001	989953	383751	1/23/2021	561.49
	PCard JE	00001	989953	383751	1/23/2021	38.16
					Account Total	573.72
	Other Repair & Maint					
	PCard JE	00001	989953	383751	1/23/2021	213.45
					Account Total	213.45
	Uniforms & Cleaning					
	PCard JE	00001	989953	383751	1/23/2021	305.33
					Account Total	305.33
					Department Total	2,395.86

**County of Adams**  
**Vendor Payment Report**

<u>2024</u>	<u>SHF- Volunteer Program</u>	<u>Fund</u>	<u>Voucher</u>	<u>Batch No</u>	<u>GL Date</u>	<u>Amount</u>
	Operating Supplies					
	PCard JE	00001	989953	383751	1/23/2021	101.67
					Account Total	101.67
					Department Total	101.67

**County of Adams**  
**Vendor Payment Report**

<u>3701</u>	<u>Stormwater Administration</u>	<u>Fund</u>	<u>Voucher</u>	<u>Batch No</u>	<u>GL Date</u>	<u>Amount</u>
	Other Communications					
	PCard JE	00007	989953	383751	1/23/2021	653.60
					Account Total	<u>653.60</u>
	Postage & Freight					
	PCard JE	00007	989953	383751	1/23/2021	2,742.43
					Account Total	<u>2,742.43</u>
					Department Total	<u><u>3,396.03</u></u>

**County of Adams**  
**Vendor Payment Report**

<u>3070I8504210</u>	<u>TANF Admin</u>	<u>Fund</u>	<u>Voucher</u>	<u>Batch No</u>	<u>GL Date</u>	<u>Amount</u>
	Equipment Rental					
	PCard JE	00015	989953	383751	1/23/2021	281.64
	PCard JE	00015	989953	383751	1/23/2021	155.09
	PCard JE	00015	989953	383751	1/23/2021	102.61
	PCard JE	00015	989953	383751	1/23/2021	.47
	PCard JE	00015	989953	383751	1/23/2021	6.64
	PCard JE	00015	989953	383751	1/23/2021	1.43
					Account Total	547.88
	Operating Supplies					
	PCard JE	00015	989953	383751	1/23/2021	25.06
					Account Total	25.06
	Other Communications					
	PCard JE	00015	989953	383751	1/23/2021	28.25
					Account Total	28.25
					Department Total	601.19

**County of Adams**  
**Vendor Payment Report**

<u>3070I8574195</u>	<u>TANF NON MON SVCS - EDUCATION</u>	<u>Fund</u>	<u>Voucher</u>	<u>Batch No</u>	<u>GL Date</u>	<u>Amount</u>
	County Client/Provider					
	PCard JE	00015	989953	383751	1/23/2021	1,220.15
	PCard JE	00015	989953	383751	1/23/2021	2,995.00
					Account Total	<u>4,215.15</u>
					Department Total	<u><u>4,215.15</u></u>

**County of Adams**  
**Vendor Payment Report**

<u>3070I8614196</u>	<u>TANF NON-RECURRENT SHT TRM BEN</u>	<u>Fund</u>	<u>Voucher</u>	<u>Batch No</u>	<u>GL Date</u>	<u>Amount</u>
	County Client/Provider					
	PCard JE	00015	989953	383751	1/23/2021	<u>386.83</u>
					Account Total	<u>386.83</u>
					Department Total	<u><u>386.83</u></u>



**County of Adams**  
**Vendor Payment Report**

<u>9291</u>	<u>Veterans Service Office</u>	<u>Fund</u>	<u>Voucher</u>	<u>Batch No</u>	<u>GL Date</u>	<u>Amount</u>
	Equipment Rental					
	PCard JE	00001	989953	383751	1/23/2021	63.58
	PCard JE	00001	989953	383751	1/23/2021	.84
	PCard JE	00001	989953	383751	1/23/2021	.63
	PCard JE	00001	989953	383751	1/23/2021	63.58
	PCard JE	00001	989953	383751	1/23/2021	.35
					Account Total	128.98
	Operating Supplies					
	DATASPEC LLC	00001	989812	383572	2/1/2021	449.00
					Account Total	449.00
					Department Total	577.98

**County of Adams**  
**Vendor Payment Report**

<u>97800</u>	<u>Wagner-Peyser</u>	<u>Fund</u>	<u>Voucher</u>	<u>Batch No</u>	<u>GL Date</u>	<u>Amount</u>
	Clnt Trng-Background Checks					
	PCard JE	00035	989953	383751	1/23/2021	39.65
					Account Total	39.65
	Other Communications					
	VERIZON WIRELESS	00035	989935	383688	2/2/2021	468.05
					Account Total	468.05
	Telephone					
	CENTURYLINK	00035	989939	383688	2/2/2021	1.96
					Account Total	1.96
					Department Total	509.66

**County of Adams**  
**Vendor Payment Report**

<u>4316</u>	<u>Wastewater Treatment Plant</u>	<u>Fund</u>	<u>Voucher</u>	<u>Batch No</u>	<u>GL Date</u>	<u>Amount</u>
	Equipment Maint & Repair					
	PCard JE	00043	989953	383751	1/23/2021	420.39
					Account Total	420.39
	Gas & Electricity					
	ROGGEN FARMERS ELEVATOR ASSN	00043	989944	383695	1/31/2021	240.00
					Account Total	240.00
	Licenses and Fees					
	PCard JE	00043	989953	383751	1/23/2021	562.12
					Account Total	562.12
	Water/Sewer/Sanitation					
	AURORA WATER	00043	989942	383695	1/31/2021	2,359.74
					Account Total	2,359.74
					Department Total	<u>3,582.25</u>

**County of Adams**  
**Vendor Payment Report**

<u>99600</u>	<u>WBC Admin Pool</u>	<u>Fund</u>	<u>Voucher</u>	<u>Batch No</u>	<u>GL Date</u>	<u>Amount</u>
	Clnt Trng - Background Checks					
	PCard JE	00035	989953	383751	1/23/2021	29.70
					Account Total	29.70
	Other Communications					
	VERIZON WIRELESS	00035	989935	383688	2/2/2021	51.44
					Account Total	51.44
					Department Total	81.14

**County of Adams**  
**Vendor Payment Report**

<u>99700</u>	<u>WIB Expenses</u>	<u>Fund</u>	<u>Voucher</u>	<u>Batch No</u>	<u>GL Date</u>	<u>Amount</u>
	Operating Supplies					
	PCard JE	00035	989953	383751	1/23/2021	118.51
					Account Total	118.51
					Department Total	118.51

**County of Adams**  
**Vendor Payment Report**

<u>99806</u>	<u>WIOA &amp; Wag/Pey Shared Prog Cst</u>	<u>Fund</u>	<u>Voucher</u>	<u>Batch No</u>	<u>GL Date</u>	<u>Amount</u>
	Other Communications					
	VERIZON WIRELESS	00035	989935	383688	2/2/2021	51.44
					Account Total	51.44
					Department Total	51.44

**County of Adams**  
**Vendor Payment Report**

<u>97200</u>	<u>WIOA ADULT PROGRAM</u>	<u>Fund</u>	<u>Voucher</u>	<u>Batch No</u>	<u>GL Date</u>	<u>Amount</u>
	Apprenticeship					
	PCard JE	00035	989953	383751	1/23/2021	1,538.11
	PCard JE	00035	989953	383751	1/23/2021	605.00
	PCard JE	00035	989953	383751	1/23/2021	605.00
					Account Total	2,748.11
	Clnt Trng-Testing					
	PCard JE	00035	989953	383751	1/23/2021	475.00
					Account Total	475.00
	Clnt Trng-Training Supplies					
	PCard JE	00035	989953	383751	1/23/2021	516.94
					Account Total	516.94
					Department Total	3,740.05

**County of Adams**  
**Vendor Payment Report**

<u>97700</u>	<u>WIOA DLW PROGRAM</u>	<u>Fund</u>	<u>Voucher</u>	<u>Batch No</u>	<u>GL Date</u>	<u>Amount</u>
	Clnt Trng-Training (not tuitio PCard JE	00035	989953	383751	1/23/2021	96.00
					Account Total	96.00
	Clnt Trng-Tuition PCard JE	00035	989953	383751	1/23/2021	1,371.10
					Account Total	1,371.10
					Department Total	1,467.10



**County of Adams**  
**Vendor Payment Report**

<u>97500</u>	<u>WIOA YOUTH OLDER</u>	<u>Fund</u>	<u>Voucher</u>	<u>Batch No</u>	<u>GL Date</u>	<u>Amount</u>
	Clnt Trng-Tuition					
	PCard JE	00035	989953	383751	1/23/2021	2,995.00
	PCard JE	00035	989953	383751	1/23/2021	1,335.00
	PCard JE	00035	989953	383751	1/23/2021	721.86
					Account Total	5,051.86
	Testing/Licensing Employment					
	PCard JE	00035	989953	383751	1/23/2021	37.50
	PCard JE	00035	989953	383751	1/23/2021	6.00
	PCard JE	00035	989953	383751	1/23/2021	6.00
					Account Total	49.50
					Department Total	5,101.36

**County of Adams**  
**Vendor Payment Report**

<u>35</u>	<u>Workforce &amp; Business Center</u>	<u>Fund</u>	<u>Voucher</u>	<u>Batch No</u>	<u>GL Date</u>	<u>Amount</u>
	Received not Vouchered Clrg					
	COMPUTER SYSTEMS DESIGN	00035	990027	383900	2/4/2021	<u>4,800.00</u>
					Account Total	<u>4,800.00</u>
					Department Total	<u><u>4,800.00</u></u>

**County of Adams**  
**Vendor Payment Report**

<u>99807</u>	<u>Youth Shared Prgrm Direct Cost</u>	<u>Fund</u>	<u>Voucher</u>	<u>Batch No</u>	<u>GL Date</u>	<u>Amount</u>
	Other Communications					
	VERIZON WIRELESS	00035	989935	383688	2/2/2021	<u>306.48</u>
					Account Total	<u>306.48</u>
					Department Total	<u><u>306.48</u></u>

**County of Adams**  
**Vendor Payment Report**

**Grand Total**      3,120,293.37



**Board of County Commissioners  
Minutes of Commissioners' Proceedings**

Eva J. Henry - District #1  
Charles "Chaz" Tedesco - District #2  
Emma Pinter - District #3  
Steve O'Doriso - District #4  
Lynn Baca - District #5

**Tuesday  
February 09, 2021  
9:30 AM**

**1. ROLL CALL**

**Present:** 5 - Commissioner Henry, Commissioner Tedesco, Commissioner Pinter, Commissioner O'Doriso, and Commissioner Baca

**2. PLEDGE OF ALLEGIANCE**

**3. MOTION TO APPROVE AGENDA**

**A motion was made by Commissioner O'Doriso, seconded by Commissioner Pinter, that this Agenda be approved. The motion carried by the following vote:**

**Aye:** 5 - Commissioner Henry, Commissioner Tedesco, Commissioner Pinter, Commissioner O'Doriso, and Commissioner Baca

**4. AWARDS AND PRESENTATIONS**

**A.** Adams County Commissioners Career Expo Award Presentation

**5. PUBLIC COMMENT**

**A.** Citizen Communication

**B.** Elected Officials' Communication

**6. CONSENT CALENDAR**

**A motion was made by Commissioner O'Doriso, seconded by Commissioner Pinter, that this Consent Calendar be approved. The motion carried by the following vote:**

**Aye:** 5 - Commissioner Henry, Commissioner Tedesco, Commissioner Pinter, Commissioner O'Dorisio, and Commissioner Baca

- A.** List of Expenditures Under the Dates of January 25-29, 2021
- B.** Minutes of the Commissioners' Proceedings from February 2, 2021
- C.** Adams County Public Trustee Operational Expense for the Quarter Ending December 2020
- D.** Resolution Approving an Intergovernmental Agreement between the City of Northglenn and the Adams County Sheriff's Office for the Provision of Law Enforcement and Administrative Personnel  
(File approved by ELT)
- E.** Resolution Approving the 2020 Colorado Department of Transportation Highway Users Tax Fund Report for Adams County  
(File approved by ELT)
- F.** Resolution Approving an Intergovernmental Agreement for Participation in a Pilot Program for Sharing Criminal Justice Information  
(File approved by ELT)
- G.** Resolution Accepting Quitclaim Deed Conveying Property from Agnes L. Domenico and Gregory L. Domenico to Adams County for the Dedication of Road Right-of-Way for York Street  
(File approved by ELT)
- H.** Resolution Approving a Programmatic Agreement between Adams County and the Colorado State Historic Preservation Officer Regarding the Administration of U.S. Department of Housing and Urban Development Programs  
(File approved by ELT)
- I.** Resolution Accepting a Permanent Access Easement from East Cherry Creek Valley Water and Sanitation District to Adams County for Storm Water Drainage Purposes  
(File approved by ELT)
- J.** Resolution Accepting a Permanent Drainage Easement from East Cherry Creek Valley Water and Sanitation District to Adams County for Storm Water Drainage Purposes  
(File approved by ELT)

- K.** Resolution Accepting a Permanent Access Easement from East Cherry Creek Valley Water and Sanitation District to Adams County for Storm Water Drainage Purposes  
(File approved by ELT)
- L.** Resolution Accepting a Permanent Drainage Easement from East Cherry Creek Valley Water and Sanitation District to Adams County for Storm Water Drainage Purposes  
(File approved by ELT)
- M.** Resolution Accepting a Special Warranty Deed from P8 D-C Industrial Last Mile, LLC to the County of Adams for Right-of-Way Purposes  
(File approved by ELT)
- N.** Resolution Accepting a Permanent Drainage Easement from P8 D-C Industrial Last Mile, LLC to Adams County for Storm Water Drainage Purposes  
(File approved by ELT)
- O.** Resolution Accepting a Roadway Maintenance Agreement from P8 D-C Industrial Last Mile, LLC to the County of Adams for Right-of-Way Purposes  
(File approved by ELT)
- P.** Resolution Accepting a Special Warranty Deed from P8 D-C Industrial Last Mile, LLC to the County of Adams for Right-of-Way Purposes  
(File approved by ELT)
- Q.** Resolution Accepting a Quitclaim Deed from Copeland Holdings, LLC to the County of Adams for Right-of-Way Purposes  
(File approved by ELT)
- R.** Resolution Accepting a Permanent Drainage Easement from Salcido Trucking, Inc. to Adams County for Storm Water Drainage Purposes  
(File approved by ELT)
- S.** Resolution Accepting a Permanent Access Easement from Salcido Trucking, Inc. to Adams County for Storm Water Drainage Purposes  
(File approved by ELT)
- T.** Resolution Appointing Ashley Dunn to the Workforce Development Board as a Business Sector Representative  
(File approved by ELT)
- U.** Resolution Appointing Dave Rose to the Planning Commission as an Alternate Member  
(File approved by ELT)

- V.** Resolution Appointing Dawn Davis to Maiker Housing Partners  
(File approved by ELT)
- W.** Resolution Appointing Emily Burr to the Cultural Council  
(File approved by ELT)
- X.** Resolution Appointing Erika Rodriguez to the Workforce Development Board as a Labor Representative  
(File approved by ELT)
- Y.** Resolution Appointing Frederick Alfred to the Adams County Foundation  
(File approved by ELT)
- Z.** Resolution Appointing Glenn Grove to the Local Emergency Planning Committee as an Adams County/Jefferson County Hazmat Representative  
(File approved by ELT)
- AA.** Resolution Appointing James Hensinger to the Adams County Visual Arts Commission  
(File approved by ELT)
- AB.** Resolution Appointing Jason Pardikes to the Building Code Board of Appeals  
(File approved by ELT)
- AC.** Resolution Appointing Jeffrey Mccarron to the Local Emergency Planning Committee as a Tri-County Health Department Representative  
(File approved by ELT)
- AD.** Resolution Appointing Julie Schilz to the Tri-County Health Department Board  
(File approved by ELT)
- AE.** Resolution Appointing Larry Caschette to the Workforce Development Board as a Business Sector Representative  
(File approved by ELT)
- AF.** Resolution Appointing Lindsay Lierman to the Citizen Review Panel  
(File approved by ELT)
- AG.** Resolution Appointing Maureen Rudy to the Workforce Development Board as an Adult Education Representative  
(File approved by ELT)
- AH.** Resolution Appointing Meagan Gallegos to the Workforce Development Board as a VOC Representative  
(File approved by ELT)



- AI.** Resolution Appointing Owen Harnett to the Board of Adjustment as an Alternate Member  
(File approved by ELT)
- AJ.** Resolution Appointing Patrick Giron to the Workforce Development Board as an Economic Development/Business Representative  
(File approved by ELT)
- AK.** Resolution Appointing Theo Gonzales to the Local Emergency Planning Committee  
(File approved by ELT)
- AL.** Resolution Appointing Thomas Brick to the Veterans Advisory Commission as a Veteran Representative  
(File approved by ELT)
- AM.** Resolution Appointing Tricia Johnson to the Workforce Development Board as a Higher Ed Representative  
(File approved by ELT)
- AN.** Resolution Appointing Trish O'Connor to the Adams County Foundation Board  
(File approved by ELT)
- AO.** Resolution Appointing Vince Chowdhury to the Adams County Foundation  
(File approved by ELT)
- AP.** Resolution Recognizing Mandy McCormick as the 2021 Adams County Fair Queen and Kira Szulinski as the 2021 Lady-in-Waiting  
(File approved by ELT)
- AQ.** Resolution Adopting Commissioners' 2021 Reorganization  
(File approved by ELT)

## **7. NEW BUSINESS**

### **A. COUNTY MANAGER**

- 1.** Resolution Authorizing First Supplemental Appropriations to the 2021 Adams County Government Budget  
(File approved by ELT)  
**A motion was made by Commissioner Tedesco, seconded by Commissioner Baca, that this New Business be approved. The motion carried by the following vote:**

**Aye:** 5 - Commissioner Henry, Commissioner Tedesco, Commissioner Pinter, Commissioner O'Dorisio, and Commissioner Baca

2. Resolution Approving Amendment One to the Agreement between Adams County and EP&A Envirotac, Inc. for Acrylic Based Soil Stabilizing Polymer (File approved by ELT)

**A motion was made by Commissioner Tedesco, seconded by Commissioner O'Dorisio, that this New Business be approved. The motion carried by the following vote:**

**Aye:** 5 - Commissioner Henry, Commissioner Tedesco, Commissioner Pinter, Commissioner O'Dorisio, and Commissioner Baca

3. Resolution Approving Amendment One to the Agreement between Adams County and GMCO Corporation for Fugitive Dust Chloride Abatement (File approved by ELT)

**A motion was made by Commissioner Tedesco, seconded by Commissioner O'Dorisio, that this New Business be approved. The motion carried by the following vote:**

**Aye:** 5 - Commissioner Henry, Commissioner Tedesco, Commissioner Pinter, Commissioner O'Dorisio, and Commissioner Baca

4. Resolution Approving Amendment One to the Agreement between Adams County and JK Transports, Inc. for Truck Hauling Services (File approved by ELT)

**A motion was made by Commissioner Tedesco, seconded by Commissioner O'Dorisio, that this New Business be approved. The motion carried by the following vote:**

**Aye:** 5 - Commissioner Henry, Commissioner Tedesco, Commissioner Pinter, Commissioner O'Dorisio, and Commissioner Baca

5. Resolution Approving a Purchase Order between Adams County and Great Lakes Hotel Supply for the Detention Center Kitchen Equipment Replacement (File approved by ELT)

**A motion was made by Commissioner Baca, seconded by Commissioner Pinter, that this New Business be approved. The motion carried by the following vote:**

**Aye:** 5 - Commissioner Henry, Commissioner Tedesco, Commissioner Pinter, Commissioner O'Dorisio, and Commissioner Baca

## **B. COUNTY ATTORNEY**

Motion to Adjourn into Executive Session Pursuant to C.R.S. 24-6-402 (4)(b) and (e) for the Purpose of Receiving Legal Advice and Instructing Negotiators Regarding Union Negotiations

**A motion was made by Commissioner Pinter, seconded by Commissioner Tedesco, that this Executive Session be approved. The motion carried by the following vote:**

**Aye: 5 -** Commissioner Henry, Commissioner Tedesco, Commissioner Pinter,  
Commissioner O'Dorizio, and Commissioner Baca

## **8. LAND USE HEARINGS**

### **A. Cases to be Heard**

1. PRC2020-00011 Lefor 128th/ Imboden Comprehensive Plan Amendment  
and Rezone

(File approved by ELT)

**A motion was made by Commissioner Pinter, seconded by  
Commissioner Baca, that this Land Use Hearing be approved. The  
motion carried by the following vote:**

**Aye: 5 -** Commissioner Henry, Commissioner Tedesco, Commissioner Pinter,  
Commissioner O'Dorizio, and Commissioner Baca

2. RCU2020-00023 461 E. 66th Rezone

(File approved by ELT)

**A motion was made by Commissioner Baca, seconded by  
Commissioner O'Dorizio, that this Land Use Hearing be approved. The  
motion carried by the following vote:**

**Aye: 5 -** Commissioner Henry, Commissioner Tedesco, Commissioner Pinter,  
Commissioner O'Dorizio, and Commissioner Baca

## **9. ADJOURNMENT**

**AND SUCH OTHER MATTERS OF PUBLIC BUSINESS WHICH MAY ARISE**



## PUBLIC HEARING AGENDA ITEM

<b>DATE OF PUBLIC HEARING:</b> February 23, 2021
<b>SUBJECT:</b> 2020 IGA with the City of Commerce City for Records Administrative Services
<b>FROM:</b> Sheriff, Richard Reigenborn
<b>AGENCY/DEPARTMENT:</b> Sheriff's Office
<b>HEARD AT STUDY SESSION ON</b>
<b>AUTHORIZATION TO MOVE FORWARD:</b> <input type="checkbox"/> YES <input type="checkbox"/> NO
<b>RECOMMENDED ACTION:</b> That the Board of County Commissioners Approves the intergovernmental agreement with Commerce City for Law Enforcement Records Administrative Services in 2020.

### **BACKGROUND:**

The attached IGA is for the Sheriff's Office to provide Law Enforcement Records Administrative services to Commerce City. As is the case with Brighton and Northglenn, Commerce City will pay Adams County to offset all costs associated with providing the services.

### **AGENCIES, DEPARTMENTS OR OTHER OFFICES INVOLVED:**

City of Commerce City

### **ATTACHED DOCUMENTS:**

IGA with the City of Commerce City  
Resolution with the City of Commerce City

**FISCAL IMPACT:**

Please check if there is no fiscal impact . If there is fiscal impact, please fully complete the section below.

<b>Fund: 1</b>
<b>Cost Center: 2018</b>

	<b>Object Account</b>	<b>Subledger</b>	<b>Amount</b>
Current Budgeted Revenue:	5885.4		\$145,624
Additional Revenue not included in Current Budget:	5885.4		\$15,017
<b>Total Revenues:</b>			<u>\$160,641</u>

	<b>Object Account</b>	<b>Subledger</b>	<b>Amount</b>
Current Budgeted Operating Expenditure:	7005		\$160,641
Add'l Operating Expenditure not included in Current Budget:			
Current Budgeted Capital Expenditure:			
Add'l Capital Expenditure not included in Current Budget:			
<b>Total Expenditures:</b>			<u>\$160,641</u>

New FTEs requested:  YES  NO

Future Amendment Needed:  YES  NO

**Additional Note:**

Budgeted Revenue and Expenditures is for three separate agreements, broken out as follows:

Brighton	\$38,553
Commerce City	\$64,256
Northglenn	\$57,830

RESOLUTION APPROVING AN INTERGOVERNMENTAL AGREEMENT BETWEEN  
THE CITY OF COMMERCE CITY AND THE ADAMS COUNTY SHERIFF'S OFFICE FOR  
THE PROVISION OF LAW ENFORCEMENT AND ADMINISTRATIVE PERSONNEL

Resolution

WHEREAS, the Commerce City Police Department has requested administrative services be provided by the Adams County Sheriff's Office; and,

WHEREAS, the Adams County Sheriff's Office employs a number of personnel who are qualified and able to assist Commerce City with the performance of administrative services; and,

WHEREAS, both parties wish to enter into the attached intergovernmental agreement for law enforcement related administrative records support.

NOW, THEREFORE, BE IT RESOLVED, by the Board of County Commissioners, County of Adams, State of Colorado, that the Intergovernmental Agreement between the City of Commerce City and the Adams County Sheriff's Office for the Provision of Law Enforcement and Administrative Personnel, a copy of which is attached hereto and incorporated herein by reference, be and hereby is approved.

BE IT FURTHER RESOLVED, that the Chair of the Board of County Commissioners is hereby authorized to execute said intergovernmental agreement on behalf of Adams County.

**INTERGOVERNMENTAL AGREEMENT BETWEEN THE CITY OF COMMERCE  
CITY AND THE ADAMS COUNTY SHERIFF’S OFFICE FOR THE PROVISION OF  
LAW ENFORCEMENT AND ADMINISTRATIVE PERSONNEL**

THIS INTERGOVERNMENTAL AGREEMENT (“IGA”) is made this \_\_\_\_\_ day of \_\_\_\_\_, 2020, the effective date, by and between the City of Commerce City, hereinafter referred to as “Commerce City,” and the Adams County Sheriff’s Office hereinafter referred to as “Adams County”. Commerce City and Adams County may be referred to herein collectively as the “Parties” and individually as a “Party.”

WHEREAS, Commerce City has requested administrative services be provided by Adams County on a continuous basis between the hours of 2200hrs and 0600hrs only, every day of the year; and

WHEREAS, Adams County employs a number of personnel who are qualified and able to assist Commerce City with the performance of said administrative services; and

WHEREAS, the Parties wish to enter into this IGA so that Commerce City may use the services of Adams County employees (herein referred to as “Assigned Employees”) to render, as applicable, administrative services during the hours of 2200hrs and 0600hrs only, as specifically designated by Adams County throughout the term of this IGA; and

WHEREAS, the Parties are willing to enter into this IGA to provide law enforcement related administrative records support upon the terms and conditions contained in this IGA.

NOW, THEREFORE, in consideration of the foregoing recitals, the covenants, promises, terms and conditions set forth herein, and other good and valuable consideration, the receipt and adequacy of which is hereby acknowledged, the Parties hereby agree as follows:

A. Designated Coordinator. Each Party will designate a representative to act as the point of contact for the administration of this IGA.

B. Allocation of Staff. Adams County shall provide law enforcement administrative records services during the hours of 2200hrs and 0600hrs only, every day of the year, whether it is via telephone, police radios, facsimile or email. Adams County shall not be obligated to furnish law enforcement administrative tasks outside of the times listed herein.

C. Assigned Employee Responsibilities. Assigned Employees who are titled Records Specialists shall be responsible for handling administrative support for and on behalf of Commerce City during the times listed herein. The administrative support responsibilities shall include, but are not limited to the following:

- NCIC and CCIC terminal monitoring
- Hit confirmations
- Warrant, Person(s), Vehicle(s), Property and other entries & clearances as needed
- Impounds and Private Tows
- Notifications

D. Employment Status of Assigned Employees. The Parties agree that the Assigned Employees shall remain employees of the Adams County Sheriff's Office and nothing herein shall be deemed to make an Assigned Employee an employee of Commerce City for any purpose. While performing within the course and scope of this IGA, an Assigned Employee shall be and remain an employee of the Adams County Sheriff's Office.

E. Rules of Conduct. The Parties agree that Assigned Employees shall be bound by rules, regulations and policies of Adams County. Any inconsistency or conflicts between the Parties regarding rules, regulations, policies and all operational disputes will immediately be brought to the attention of the other party and will be fully and finally addressed and resolved by the Sheriff and/or Chief of Police, the senior executive, or his or her designee in accordance with his or her determination of the best practices under the circumstances. The Parties may delegate this responsibility to a specific command officer or manager.

F. Fees. Assigned Employees. Commerce City shall pay Adams County for administrative services at the rate of \$64,256.40/year. Adams County may adjust said fee annually as necessary to reflect increased costs for providing administrative services to Commerce City. Adams County is entering into several similar intergovernmental agreements with other municipalities. No later than May 1<sup>st</sup> of each calendar year Adams County will provide an annual usage analysis of each of the municipalities with whom it has a similar intergovernmental agreement, along with the recommended associated fees for each jurisdiction for the following year. The recommended fees for service will be divided proportionally, based on the usage analysis, between all parties receiving said administrative law enforcement services. The Adams County Administrative Services staff will be required to track each supported agency's request for assistance using the following categories:

- Phone/Email (including nature of request)
- Locates/Cancel/Confirmations
- Impounds/Repo/Private Tows
- NCIC/CCIC Entries/Clearances

G. Term. The term of this agreement shall be from January 1, 2021 to December 31, 2021.

H. Payment. By the 15<sup>th</sup> of each month, Adams County shall submit an invoice to Commerce City for 1/12 of the amount stated in Paragraph F for services provided the previous month. Commerce City shall pay Adams County within thirty (30) days of the invoice date. Non-payment constitutes a material breach of this agreement and unless corrected, this agreement shall automatically terminate, relieving Adams County of any and all obligations herein. Termination does not relieve Commerce City of its obligation to pay Adams County for costs of previously Assigned Employees under this agreement.

I. Indemnification. To the extent permitted by law, Commerce City shall indemnify, defend, save and hold harmless Adams County, its departments, agencies, boards, commissions, officers, officials, agents, and employees ("Indemnitee") for, from and against any and all claims, actions, liabilities, damages, losses, or expenses (including court costs, attorneys' fees, and costs of claim processing, investigation and litigation) ("Claims") for bodily injury or personal injury (including death), or loss or damage to tangible or intangible property caused, or alleged to be caused, in whole or in part, by the negligent acts of the Assigned Employees. Nothing in this IGA is meant to waive the parties' protections pursuant to the Colorado Governmental Immunity Act.



J. Entire Agreement. This IGA embodies the entire understanding of the parties and supersedes any other agreement or understanding between the parties relating to the subject matter of this IGA. No other oral or written representations made prior to the execution of this agreement shall constitute a part of the agreement. All amendments to this agreement shall be in writing and executed by both parties, and no amendment shall be binding or effective unless a written amendment is so executed.

K. Severability. The provisions of this IGA are severable to the extent that any provision or application held to be invalid by a court of competent jurisdiction shall not affect any other provision or application of the IGA which may remain in effect without the invalid provision or application.

L. Governing Law. This IGA shall be governed by and construed in accordance with the laws of the State of Colorado. Venue for any dispute shall be in Adams County, Colorado.

M. Termination. Either Party may, at any time, terminate this IGA by giving the other Party not less than sixty (60) days prior written notice.

N. Headings. Headings of this IGA are for convenience only and shall not affect the interpretation of this IGA.

O. Notices. Other than requests for staffing, written notices required under this IGA and all other correspondence between the parties shall be directed to the following and shall be deemed received when hand-delivered or three (3) days after being sent by certified mail, return receipt requested:

Commerce City

Name: Clint Nichols  
Title: Chief of Police  
Address: 7887 E. 60<sup>th</sup> Avenue  
Commerce City, CO 80022

Adams County

Name: Stephanie Brandt  
Title: Operations Supervisor  
Address: 4430 S Adams County Pkwy  
1<sup>st</sup> Floor, Suite W5400  
Brighton, Co 80601

IN WITNESS WHEREOF, the Parties have executed this IGA on the date first written above.

**CITY OF COMMERCE CITY**

DocuSigned by:  
*Clint Nichols*  
FA6172B7490C481...

Chief of Police

ATTEST:

DocuSigned by:  
*Dylan Gibson*  
798CD14FB5714B1...

City Clerk

Approved as to form: DocuSigned by:

*Maxim R. H...*  
B9B9238F9DED45F...

City Attorney

**ADAMS COUNTY SHERIFF'S OFFICE**

\_\_\_\_\_  
Sheriff

\_\_\_\_\_  
Printed Name

**ADAMS COUNTY, COLORADO  
BOARD OF COUNTY COMMISSIONERS**

\_\_\_\_\_  
Chair

\_\_\_\_\_  
Date

ATTEST:

\_\_\_\_\_  
Deputy Clerk

Approved as to form:

\_\_\_\_\_  
Adams County Attorney's Office



## PUBLIC HEARING AGENDA ITEM

<b>DATE OF PUBLIC HEARING:</b> February 23, 2021
<b>SUBJECT:</b> Resolution approving right-of-way agreement between Adams County and Isaac Mares and The David J. Mares and Rose M. Mares Trust dated December 18, 2017, for property necessary for the Dahlia Street Roadway and Drainage Improvements Project from East 74 <sup>th</sup> Avenue to East 78 <sup>th</sup> Avenue
<b>FROM:</b> Kristin Sullivan, AICP, Director of Public Works Brian Staley, P.E., PTOE, Deputy Director of Public Works
<b>AGENCY/DEPARTMENT:</b> Public Works
<b>HEARD AT STUDY SESSION ON:</b> N/A
<b>AUTHORIZATION TO MOVE FORWARD:</b> <input type="checkbox"/> YES <input type="checkbox"/> NO
<b>RECOMMENDED ACTION:</b> That the Board of County Commissioners approves the right-of-way agreement for acquisition of property interests needed for the Dahlia Street Roadway and Drainage Improvements Project.

### **BACKGROUND:**

Adams County is in the process of acquiring property interests along the Dahlia Street corridor from East 74<sup>th</sup> Avenue to East 78<sup>th</sup> Avenue for the Dahlia Street Roadway and Drainage Improvement Project. The intention of this Project is to identify and improve the overall roadway and drainage of Dahlia Street. Attached is a copy of the right-of-way agreement between Adams County and Isaac Mares and The David J. Mares and Rose M. Mares Trust dated December 18, 2017, for acquisition of property interests in the amount of \$6,700.00. The attached resolution allows the County to acquire ownership of the property interests needed for the use of the public and provide the necessary documents to close on the property.

### **AGENCIES, DEPARTMENTS OR OTHER OFFICES INVOLVED:**

Adams County Public Works, Office of the County Attorney and Adams County Board of County Commissioners.

### **ATTACHED DOCUMENTS:**

Draft resolution  
Right-of-way agreement

**FISCAL IMPACT:**

Please check if there is no fiscal impact . If there is fiscal impact, please fully complete the section below.

<b>Fund: 13</b>
<b>Cost Center: 3056</b>

	<b>Object Account</b>	<b>Subledger</b>	<b>Amount</b>
Current Budgeted Revenue:			
Additional Revenue not included in Current Budget:			
<b>Total Revenues:</b>			<u>                    </u>

	<b>Object Account</b>	<b>Subledger</b>	<b>Amount</b>
Current Budgeted Operating Expenditure:			
Add'l Operating Expenditure not included in Current Budget:			
Current Budgeted Capital Expenditure:	9135	30562101	\$15,000,000
Add'l Capital Expenditure not included in Current Budget:			
<b>Total Expenditures:</b>			<u><b>\$15,000,000</b></u>

New FTEs requested:             YES             NO

Future Amendment Needed:     YES             NO

**Additional Note:**

BOARD OF COUNTY COMMISSIONERS FOR  
ADAMS COUNTY, STATE OF COLORADO

RESOLUTION APPROVING RIGHT-OF-WAY AGREEMENT BETWEEN ADAMS  
COUNTY AND ISAAC MARES AND THE DAVID J. MARES AND ROSE M. MARES  
TRUST DATED DECEMBER 18, 2017 FOR PROPERTY NECESSARY FOR THE DAHLIA  
STREET ROADWAY AND DRAINAGE IMPROVEMENTS PROJECT FROM EAST 74<sup>TH</sup>  
AVENUE TO EAST 78<sup>TH</sup> AVENUE

WHEREAS, Adams County is in the process of acquiring right-of-way and easements along Dahlia Street corridor from East 74<sup>th</sup> Avenue to East 78<sup>th</sup> Avenue for the Dahlia Street Roadway and Drainage Improvements Project (the “Project”); and,

WHEREAS, the intention of this Project is to identify and improve the overall roadway and drainage (the “Improvements”); and,

WHEREAS, this right-of-way acquisition is a portion of 7410 Dexter Street located in the Southwest Quarter of Section 31, Township 2 South, Range 67 West of the 6<sup>th</sup> Principal Meridian, County of Adams, State of Colorado, and owned by Isaac Mares and The David J. Mares and Rose M. Mares Trust dated December 18, 2017 (“Parcel 4”); and,

WHEREAS, Adams County requires ownership of Parcel 4 for construction of the Improvements; and,

WHEREAS, Isaac Mares and The David J. Mares and Rose M. Mares Trust dated December 18, 2017, are willing to sell Parcel 4 to Adams County under the terms and conditions of the attached Right-of-Way Agreement.

NOW, THEREFORE, BE IT RESOLVED by the Board of County Commissioners, County of Adams, State of Colorado, that the attached Right-of-Way Agreement between Adams County and Isaac Mares and The David J. Mares and Rose M. Mares Trust dated December 18, 2017, a copy of which is attached hereto and incorporated herein by this reference, be and hereby is approved.

BE IT FURTHER RESOLVED that the Chair of the Board of County Commissioners is hereby authorized to execute said Right-of-Way Agreement on behalf of Adams County.

## Right-of-Way Agreement

This Agreement is made and entered into by and between **Isaac Mares & The David J. Mares and Rose M. Mares Trust dated December 18, 2017** whose address is **7471 Dexter Street, Commerce City, Colorado 80022** (“Owner”), and the County of Adams, State of Colorado, a body politic, who address is 4430 South Adams County Parkway, Brighton, Colorado, 80601 (“County”) for the conveyance of rights-of-way on property located 7410 Dexter Street, Commerce City, Colorado 80022 hereinafter (the “Property”) for the Dahlia Street Roadway and Drainage Improvements, E. 74<sup>th</sup> Ave to E. 78<sup>th</sup> Ave (the “Project”). The legal description and conveyance documents for the interests on said Property are set forth in Exhibit A attached hereto and incorporated herein by this reference.

The compensation agreed to by the Owner and the County for the acquisition of the Property interests described herein is **SIX THOUSAND SEVEN HUNDRED AND NO/100 DOLLARS (\$6,700.00)**, including the performance of the terms of this Agreement, the sufficiency of which is hereby acknowledged. The parties further agree that the consideration shall consist of \$6,400.00 for the conveyance of road right-of-way, \$275.00 for the conveyance of a temporary construction easement and \$25.00 for relocation of the trampoline from the easement area. This consideration has been agreed upon and between the parties as the total just compensation due to the Owner and the consideration shall be given and accepted in full satisfaction of this Agreement.

In consideration of the above premises and the mutual promise and covenants below, the Owner and the County agree to the following:

1. The Owner hereby warrants that the Owner is the sole Owner of the Property, that the Owner owns the Property in fee simple subject only to matters of record and that the Owner has the power to enter into this Agreement.
2. The Owner agrees to execute and deliver to the County the attached conveyance documents on the property upon tender by the County of a warrant (check) for the compensation agreed upon as soon as possible following the execution of this agreement.
3. The Owner hereby irrevocably grants to the County possession and use of the property interests on the Property upon execution of this Agreement by the Owner and the County. This grant of possession shall remain in effect with respect to the Property until such time as the County obtains from the Owner the attached conveyance documents.
4. The Owner agrees to pay all 2019 taxes due in 2020 prior to tender by the County.
5. The County through its contractor shall assure that reasonable access shall be maintained to the Owner’s property at all times for ingress and egress. If necessary,

any full closure of access shall be coordinated between the contractor and the Owner and/or its agent.

6. The County will remove and replace approximately 60 lineal feet of wood privacy fence as part of the project.
7. The County will require the trampoline located in the backyard to be moved out of the Temporary Construction Easement area. Thus, the County has agreed to reimburse the Owner, \$25.00 for the relocation of the trampoline by the Owner.
8. The Owner has entered into this Agreement acknowledging that the County has the power of eminent domain and required the Property for a public purpose.
9. If the Owner fails to consummate this agreement for any reason, except the County's default, the County may at its option, enforce this agreement by bringing an action against the Owner for specific performance.
10. This Agreement contains all agreements, understandings and promises between the Owner and the County, relating to the Project and shall be deemed a contract binding upon the Owner and County and extending to the successors, heirs and assigns.
11. The Owner shall be responsible for reporting proceeds of the sale to taxing authorities, including the submittal of Form 1099-S with the Internal Revenue Service, if applicable.
12. This Agreement has been entered into in the State of Colorado and shall be governed according to the laws thereof.

Isaac Mares:

By: Isaac Mares

Date: 1-5-2021

The David J. Mares & Rose M. Mares  
Trust dated December 18, 2017:

By: Rose Mares

Date: 1-5-2021

Title: Trustee

Approved:

BOARD OF COUNTY COMMISSIONERS-COUNTY OF ADAMS, STATE OF COLORADO

\_\_\_\_\_  
Chair

\_\_\_\_\_  
Date

Approved as to Form:

\_\_\_\_\_  
County Attorney





## PUBLIC HEARING AGENDA ITEM

<b>DATE OF PUBLIC HEARING:</b> February 23, 2021
<b>SUBJECT:</b> Facility Usage Agreement (WaterWorld Testing Site)
<b>FROM:</b> Nicci Beauprez, Project Manager – Land & Assets
<b>AGENCY/DEPARTMENT:</b> Facilities & Fleet Management
<b>HEARD AT STUDY SESSION ON:</b> 8/4/2020
<b>AUTHORIZATION TO MOVE FORWARD:</b> <input checked="" type="checkbox"/> YES <input type="checkbox"/> NO
<b>RECOMMENDED ACTION:</b> That the Board of County Commissioners approves the Amendment 2 To Facility Usage Agreement – Amendment 1 to support the public COVID-19 testing site at WaterWorld.

### **BACKGROUND:**

On August 11, 2020 Adams County approved a Facility Usage agreement with Hyland Hills Park & Receptions District for the WaterWorld COVID Test Site. Attached is the second Amendment to the Facility Usage Agreement for the Board's consideration for rental of a portion of WaterWorld parking lots to locate a public site for COVID-19 testing through the month of March 2021. The project is a partnership with the Colorado Department of Public Health and Environment, which is contracting the testing agency, and will provide all personnel, materials, supplies and oversight for testing. The County will provide the leased location, traffic control/security, and other support logistics.

### **AGENCIES, DEPARTMENTS OR OTHER OFFICES INVOLVED:**

County Manager's Office, County Attorney's Office, Facilities & Fleet Management

### **ATTACHED DOCUMENTS:**

Resolution  
Amendment 2 to Facility Usage Agreement

**FISCAL IMPACT:**

Please check if there is no fiscal impact . If there is fiscal impact, please fully complete the section below.

<b>Fund: 1</b>
<b>Cost Center: 9264</b>

	<b>Object Account</b>	<b>Subledger</b>	<b>Amount</b>
Current Budgeted Revenue:			
Additional Revenue not included in Current Budget:			
<b>Total Revenues:</b>			<u>                    </u>

	<b>Object Account</b>	<b>Subledger</b>	<b>Amount</b>
Current Budgeted Operating Expenditure:			
Add'l Operating Expenditure not included in Current Budget:	7915	92642102	\$15,000
Current Budgeted Capital Expenditure:			
Add'l Capital Expenditure not included in Current Budget:			
<b>Total Expenditures:</b>			<u>                    </u> <b>\$15,000</b>

**New FTEs requested:**                     YES             NO

**Future Amendment Needed:**         YES             NO

**Additional Note:**

Original agreement was \$20,000 for August and September, October was \$0. November and December was \$10,000 totaling \$30,000 for August through December. January Through March is \$5,000 per month totaling \$15,000 for the current term and \$45,000 since inception. However, Hyland Hills has stated that if the County is not reimbursed as anticipated Hyland Hills will waive \$5,000 due for March.

BOARD OF COUNTY COMMISSIONERS FOR  
ADAMS COUNTY, STATE OF COLORADO

RESOLUTION APPROVING AMENDMENT 2 TO FACILITY USAGE AGREEMENT  
BETWEEN ADAMS COUNTY AND HYLAND HILLS PARK AND RECREATION  
DISTRICT FOR A PUBLIC COVID-19 TESTING SITE

Resolution 21-

WHEREAS, Adams County has been asked to assist the Colorado Department of Public Health and Environment to expand COVID-19 testing locations during the current COVID-19 pandemic; and,

WHEREAS, Hyland Hills Park and Recreation District has a sufficient site to provide such a location at its WaterWorld facility, located at 8801 North Pecos Street, Federal Heights, Colorado; and,

WHEREAS, Adams County and Hyland Hills Park and Recreation District entered into a Facility Usage Agreement on August 6, 2020 as amended by Amendment 1 to Facility Usage Agreement; and

WHEREAS, Adams County would like to continue to use the WaterWorld facility as a COVID-19 testing location; and,

WHEREAS, Hyland Hills Park and Recreation District would like to offer use of its property for the purpose of a testing site to Adams County under the terms and conditions of the attached Amendment 2 to Facility Usage Agreement through March 2021.

NOW THEREFORE, BE IT RESOLVED, by the Board of County Commissioners, County of Adams, State of Colorado that Amendment 2 to Facility Usage Agreement, a copy of which is attached hereto and incorporated herein by reference, be and hereby is approved.

BE IT FURTHER RESOLVED, that the Chair of the Board of County Commissioners is hereby authorized to execute said Amendment 2 to Facility Usage Agreement on behalf of Adams County.

## AMENDMENT 2 TO FACILITY USAGE AGREEMENT

THIS AMENDMENT 2 is made and entered into this 19<sup>th</sup> day of January, 2021, by and between Adams County, Colorado, located at 4430 S. Adams County Parkway, Brighton, Colorado, 80601 ("User") and the Hyland Hills Park and Recreation District, a quasi-municipal corporation and subdivision of the State of Colorado ("Hyland Hills").

### RECITALS

A. WHEREAS, the Parties entered into a Facility Usage Agreement dated August 6, 2020 for Covid-19 Testing at the Water World Parking Lot located at 8801 North Pecos Street, Federal Heights, Colorado ("Agreement"); and,

B. WHEREAS, by means of Amendment 1 to the Agreement the parties extended the termination date through December 31, 2020; and,

C. WHEREAS, by means to this Amendment 2 the parties wish to extend the term of the Agreement through March 31, 2021.

NOW, therefore, in consideration of the promises, conditions and covenants contained herein, the receipt and sufficiency of which is hereby acknowledged, the parties agree as follows:

1. The term of the Agreement is extended through March 31, 2021.
2. The definition of "Other Party" shall include parties with written agreements to use portions of the Water World parking lots during the term of the Agreement.
3. User shall conclude tear down of its facilities and parking lot stake repair by April 9, 2021.
4. Payment shall be \$5,000 for January 2021 and \$5,000 for February 2021, due upon receipt of an invoice from Hyland Hills. County shall apply to FEMA for funds for a \$5,000 March payment. However, the March payment is expressly contingent on the receipt of federal funds. In the event no federal funds are received for the March payment, the March payment shall be waived.

5. Exhibit B is replaced with the attached Exhibit B.
6. Except as modified by this Amendment 2, the terms of the Agreement shall remain in full force and effect.

IN WITNESS WHEREOF, the parties hereto have caused their names to be affixed hereto.

ADAMS COUNTY:

HYLAND HILLS:

By: \_\_\_\_\_  
Chair  
Date: \_\_\_\_\_

By: Wanda Steinhilber  
Director  
Date: 11/19/21

Approved to Form

\_\_\_\_\_  
County Attorney's Office

Exhibit B – Lots B & C for the period January 1, 2021 through March 31, 2021.

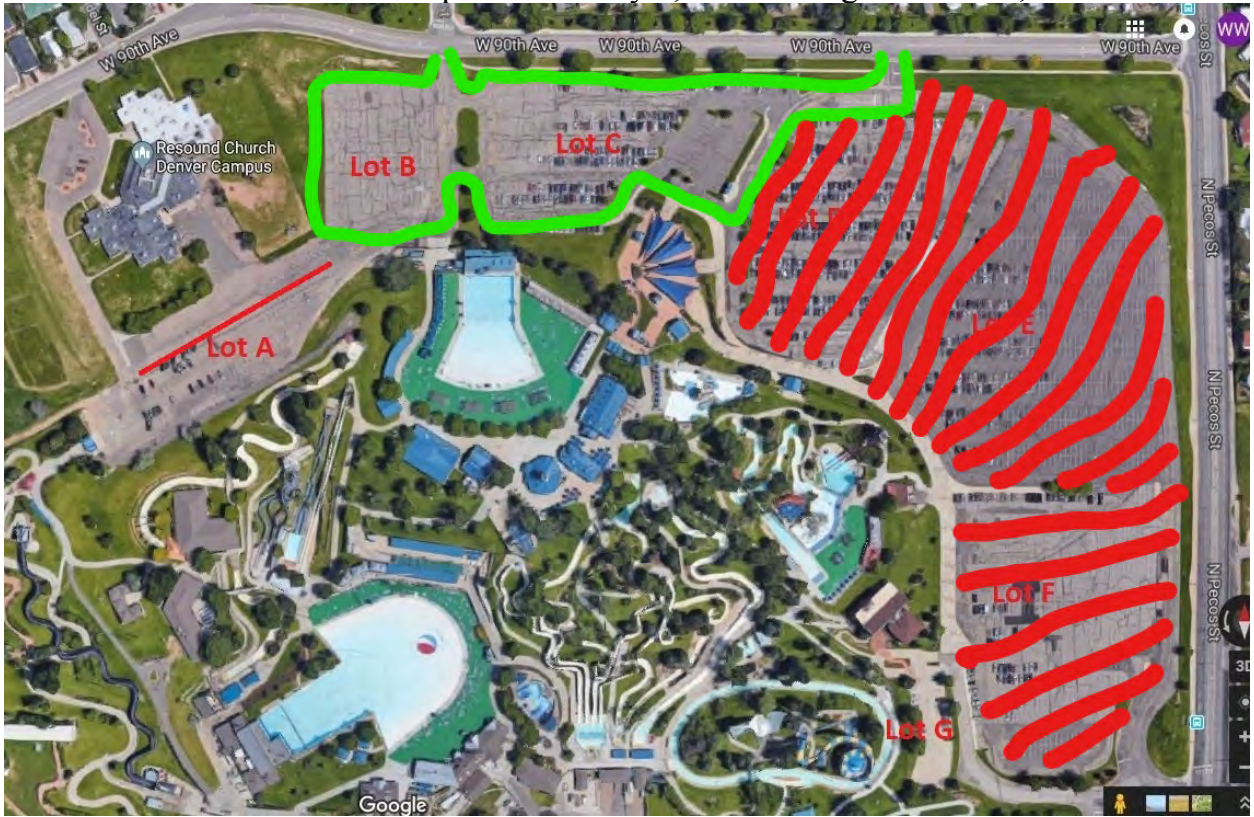



## PUBLIC HEARING AGENDA ITEM

<b>DATE OF PUBLIC HEARING:</b> 02/23/2021
<b>SUBJECT:</b> Resolution Approving Continuance of Intergovernmental Agreement with A-Lift Policy Council Partners
<b>FROM:</b> Rebecca Zamora
<b>AGENCY/DEPARTMENT:</b> Community Safety and Well-Being
<b>HEARD AT STUDY SESSION ON:</b> * AIR 06/25/19
<b>AUTHORIZATION TO MOVE FORWARD:</b> <input checked="" type="checkbox"/> YES <input type="checkbox"/> NO
<b>RECOMMENDED ACTION:</b> That the Board of County Commissioners approves the resolution.

### **BACKGROUND:**

A-Lift Policy Council partners have renewed IGA's with Adams County to continue A-Lift Policy Council Municipal Partnership. This municipal partnership, with the cities of, Arvada, Commerce City, Federal Heights, Northglenn, Thornton, and Westminster work together to coordinate the A-Lift program a transit service for seniors and special needs residents in Adams County. This council represents over a decade of successful collaboration and generates an additional \$200,000 in collaborative funding a year for the A-Lift Community Transit Program.

This was set for signature for 07/09/19 however due to a clerical issue it was stalled and the program moved departments. That staff later left and unfulfilled action items were discovered as staff began updating files after our Policy Council 2020 retreat. It is important to know that both the program and Policy Council has successfully continued without interruption.

### **AGENCIES, DEPARTMENTS OR OTHER OFFICES INVOLVED:**

Community Safety and Well-Being

### **ATTACHED DOCUMENTS:**

Resolution  
IGA's  
Public Hearing Agenda Item Form

**FISCAL IMPACT:**

Please check if there is no fiscal impact . If there is fiscal impact, please fully complete the section below.

**Fund:** 0001

**Cost Center:** 1033

	<b>Object Account</b>	<b>Subledger</b>	<b>Amount</b>
Current Budgeted Revenue:	5690		575,000
Additional Revenue not included in Current Budget:			
<b>Total Revenues:</b>			<u>575,000</u>

	<b>Object Account</b>	<b>Subledger</b>	<b>Amount</b>
Current Budgeted Operating Expenditure:	7630		710,000
Add'l Operating Expenditure not included in Current Budget:			
Current Budgeted Capital Expenditure:			
Add'l Capital Expenditure not included in Current Budget:			
<b>Total Expenditures:</b>			<u>710,000</u>

**New FTEs requested:**             YES             NO

**Future Amendment Needed:**     YES             NO

**Additional Note:**



BOARD OF COUNTY COMMISSIONERS FOR  
ADAMS COUNTY, STATE OF COLORADO

RESOLUTION APPROVING CONTINUANCE OF INTERGOVERNMENTAL  
AGREEMENT BETWEEN ADAMS COUNTY AND THE MUNICIPAL PARTNERS FOR  
THE A-LIFT TRANSIT PROGRAM

WHEAREAS, Adams County, in partnership with the Cities of Arvada, Commerce City, Federal Heights, Northglenn, Thornton, and Westminster (the “municipal partners”) work together with DRCOG to coordinate the A-Lift Transit Program (“A-Lift Program”), a transit service for seniors and residents with special needs in Adams County; and

WHEAREAS, the municipal partners have continued to provide support and leadership for the A-Lift Program through the Policy Council for the past thirty years; and

WHEAREAS, the municipal partners have provided a collective \$200,000 contribution towards the A-Lift Program yearly since 2017; and

WHEAREAS, the A-Lift Program continues to provide service to seniors and residents with special needs in Adams County; and

WHEAREAS, the current intergovernmental agreements, entered into in 2017, reflect ongoing and historical successful collaboration of the municipal partners; and

WHEAREAS, ongoing collaboration for the A-Lift Program is set to continue for the foreseeable future for our shared community through the Policy Council; and

WEAREAS, due to a clerical error, Adams County needs to update the Intergovernmental Agreements from 2017 between Adams County and the municipal partners by providing signatures to those agreements to ensure the historical and future work of the A-Lift Program;

NOW, THEREFORE, BE IT RESOLVED, by the Board of County Commissioners, County of Adams, State of Colorado, that Adams County will acknowledge and sign the Intergovernmental Agreements from 2017 between the municipal partners and Adams County for the A-Lift Program to continue providing transportation services for Adams County residents.

BE IT FURTHER RESOLVED that the Chair of the Board of County Commissioners is hereby authorized to sign said Intergovernmental Agreements from 2017 between Adams County and the municipal partners on behalf of Adams County.

INTERGOVERNMENTAL AGREEMENT WITH THE CITY OF ARVADA  
CONCERNING THE ADAMS COUNTY COMMUNITY  
TRANSIT PROGRAM (a.k.a. ALIFT)

THIS INTERGOVERNMENTAL AGREEMENT ("IGA") is made and entered into this 6th day of February, 2017 by and between the Board of County Commissioners ("BOCC"), County of Adams ("County"), a political subdivision of the State of Colorado, located at 4330 South Adams County Parkway, Brighton, Colorado 80601, and the City of Arvada ("City"), located at 8101 Ralston Road, Arvada, Colorado 80001.

WHEREAS, the Parties are authorized to enter into cooperative agreements pursuant to the Colorado Constitution, Article XIV, § 18, and § 29-1-203, C.R.S.; and,

WHEREAS, the Parties wish to enter into this IGA to enhance cooperation between the Parties and to increase the availability of transit services in meeting a portion of the unmet transit needs of older adults and persons with disabilities in the unincorporated areas and municipalities within the County; and,

WHEREAS, the Parties have formed the Adams County Community Transit Policy Council ("Policy Council") to facilitate the development of special transit services within the County and the municipalities; and,

WHEREAS, the Policy Council has been responsible for the development of special transit services within the County and the municipalities, has assisted in the development of a budget, and has assisted in the review and selection of a transportation broker; and,

WHEREAS, the Policy Council has developed a budget that anticipates expenditures required for the continuation of special transit service delivery; and,

WHEREAS, the Policy Council will continue to facilitate the sharing of responsibility for providing special transit services among the County and the municipalities; and,

WHEREAS, the Parties have agreed to allocate funding on an annual basis for the Community Transit Program; and,

WHEREAS, each of the Parties has agreed to appoint a representative and an alternate who can act on behalf of their jurisdiction to serve as a member of Policy Council.

NOW, THEREFORE, the Parties mutually agree as follows:

SECTION A - COMMUNITY TRANSIT PROGRAM SCOPE AND ADMINISTRATION

This Community Transit Program shall consist of the continuation of special transit service delivery for eligible residents of Adams County. The Community Transit Program shall be carried out in accordance with the direction of the Policy Council and the Adams County Community Transit Program Manager.

Responsibilities of the Policy Council

The Policy Council is comprised of one representative appointed by each municipal jurisdiction that funds the Community Transit Program and two appointed representatives of the Adams County Board of County Commissioners. The representatives will act on behalf of their jurisdiction and will have voting authority. Each municipal representative shall have an alternate who can attend Policy Council meetings in the representative's absence.

The Policy Council will be responsible for activities including, but not limited to, setting fares, establishing rider eligibility criteria, approving service delivery contracts, approving the annual budget, authorizing submission of grant applications and other funding requests, receiving public comments on services provided, and shall provide policy direction for the Community Transit Program.

Responsibilities of the County

The administration, oversight and management of the Community Transit Program shall be provided by Adams County staff.

The County shall act as the contracting agency for the purposes of application of eligible local, State, and Federal transit funds for the Community Transit Program.

The County shall obtain all funding agency approvals and permits that are required or otherwise necessary to execute the Community Transit Program.

The County shall act as Fiscal Agent for such funds and be responsible for the disbursement of funds on behalf of all Parties.

The County shall provide necessary financial and performance reports and other information to the Policy Council as requested.

The County shall contract with a Transportation Broker to administer the Community Transit Program.

## Responsibilities of the Transportation Broker

The responsibilities of the Transportation Broker will include, but not be limited to, scheduling the most cost-effective trips, offering information and referral, and/or providing transportation services for all eligible residents in Adams County.

The Transportation Broker will provide transportation scheduling services and transportation for eligible residents who have mobility impairments, regardless of age, or who are sixty (60) years of age or over, including wheelchair bound older adults, to medical and dental appointments, grocery facilities and congregate meal sites.

If the actual service delivery deviates more than 5% in any category from the annual goals set by Council, the Transportation Broker shall brief the Policy Council and receive prior written authorization from the Community Transit Program Manager.

The Transportation Broker shall generally provide the trips on a scheduled or prearranged basis.

The Transportation Broker shall provide complete information and referral to eligible residents about available services and resources, including but not limited to, name, address, and telephone number of other service or resource providers, and/or provide the eligible resident with a referral to appropriate community resources to ensure that necessary services will be delivered.

The Transportation Broker will provide monthly performance reports to the Community Transit Program Manager that shall detail the following:

- The total number of trips provided
- Specify client type
- Specify the passenger's city or unincorporated place of residence
- Specify the passenger's destination location and city
- Identify the classification of the trip (congregate nutrition, medical/dental, grocery, or other)
- Specify the method of transportation used (taxi, bus, community wheels)
- Identify the funding account to be charged to pay for trip cost
- Identify the number of trips that were unable to be provided by jurisdiction and the reason trip was not provided
- A program income report

## SECTION B - TERM

The IGA commences on January 1, 2017 and shall automatically renew in successive one-year qualification periods, unless either party provides written notice to terminate the IGA at least thirty days prior to the expiration of a given term.

## SECTION C - COMMUNITY TRANSIT PROGRAM FUNDING

The Community Transit Program's administrative and operating funds may be obtained from a variety of sources, including but not limited to: Regional Transportation District, Title III Older Americans Act, Denver Regional Council of Governments, participating local governments, and the Colorado Department of Transportation.

The City and County local government funds allocated to this project will be determined on an annual basis by a vote of the Adams County Community Transit Policy Council and subject to annual appropriation by the governing body of the City and the County.

## SECTION D - REIMBURSEMENTS

In the event this IGA is terminated, all funds paid by the City or the County and not committed at the time of termination of this IGA shall be refunded.

## SECTION E - INSURANCE

The Parties shall each maintain insurance, in the form of a self-insurance program and/or insurance policies, to adequately insure the Party against any claims and/or damages that might arise as a result of its performance or failure to perform under this IGA.

## SECTION F - NO INDEMNIFICATION

Each Party agrees to be responsible for the actions of its officials and employees in the performance of this IGA. Nothing herein shall be deemed as a waiver by any party of the rights, immunities and limitations afforded each by the Colorado Governmental Immunity Act CRS 24-10-101, as amended, or otherwise available at law.

## SECTION G - TERMINATION FOR CAUSE

This IGA shall not be terminated by any Party for convenience but may only be terminated for cause. Cause for termination shall consist of either a failure by one of the Parties to perform pursuant to the terms of this IGA, or a lack of available funding as described in Section C of the IGA. If termination is due to the failure of one of the Parties to perform pursuant to the terms of this IGA, the termination shall be effective thirty (30) days after written notice of the termination and cause(s) thereof have been given to the Parties, and the alleged non-performing Party has failed to cure the non-performance within the thirty (30) day period.

SECTION H - NOTICE

Any notices given under this IGA are deemed to have been received and to be effective: (a) three (3) days after the notice is mailed by certified mail, return receipt requested; (b) immediately upon hand delivery; or (c) immediately upon receipt of confirmation that a facsimile was received. For the purposes of this IGA, any and all notices shall be addressed to the contacts listed below:

Adams County Board of County  
Commissioners

4430 South Adams County Parkway 5<sup>th</sup> floor  
Suite C5000A  
Brighton, CO 80601  
Phone: 720-523-6100  
FAX: 720- 523-6045

Adams County Attorney's Office

4430 South Adams County Parkway  
5<sup>th</sup> floor Suite C5000B  
Brighton, CO 80601  
Phone: 720-523-6116  
FAX: 720-523-6114

Adams County Department of Human Services

Community Transit Program Manager  
7190 Colorado Blvd.  
Commerce City, CO  
80022  
Phone: (303) 227-2283  
FAX: (303) 227-2211

Housing Preservation and  
Resources

City of Arvada  
8101 Ralston Road  
Arvada, Colorado 80002

## SECTION I - ASSIGNABILITY

Neither this IGA, nor any rights hereunder, in whole or in part, shall be assignable or otherwise transferable by the Parties without the prior written consent of all of the Parties.

## SECTION J - VENUE AND JURISDICTION

The laws of the State of Colorado shall govern as to the interpretation, validity, and effect of this IGA. The Parties agree that jurisdiction and venue for any disputes arising under this IGA shall be in Adams County, Colorado.

## SECTION K - INTEGRATION OF UNDERSTANDING

This IGA contains the entire understanding of the Parties, and neither it, nor the rights and obligations hereunder, may be changed, modified, or waived except by an instrument in writing that is signed by all of the Parties.

## SECTION L - SEVERABILITY

If any provision of this IGA is determined to be unenforceable or invalid for any reason, the remainder of this IGA shall remain in effect, unless otherwise terminated in accordance with the terms contained herein.

## SECTION M - AUTHORIZATION

Each Party represents and warrants that it has the power and ability to enter into this IGA, to grant the rights granted herein, and to perform the duties and obligations herein described.

## SECTION N - RIGHTS OF THIRD PARTIES

This IGA does not and shall not be deemed to confer on any third party the right to the performance or proceeds under this IGA or to claim any damages or bring any legal action or other proceeding against the parties to this IGA for any breach or other failure to perform this IGA.

IN WITNESS WHEREOF, the Parties have caused their names to be affixed hereto.

DATED this 6th day of February, 2017

CITY OF ARVADA,  
a Colorado municipal corporation

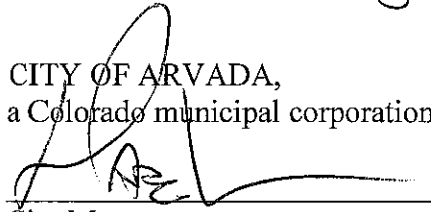

City Mayor  
City of Arvada  
8101 Ralston Road  
Arvada, Colorado 80002

Attest (Seal)

  
City Clerk

BOARD OF COUNTY  
COMMISSIONERS  
ADAMS COUNTY, COLORADO

\_\_\_\_\_  
Chairperson

Attest (Seal)

Clerk  
Board of County Commissioners

\_\_\_\_\_  
Deputy Clerk

APPROVED AS TO FORM:

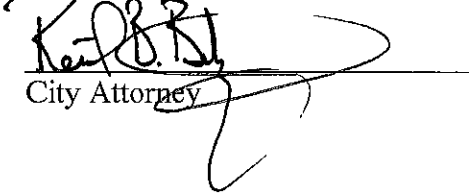
  
City Attorney

APPROVED AS TO FORM:

  
Adams County Attorney's Office



INTERGOVERNMENTAL AGREEMENT WITH THE CITY OF COMMERCE CITY  
CONCERNING THE ADAMS COUNTY COMMUNITY TRANSIT PROGRAM

THIS INTERGOVERNMENTAL AGREEMENT (“IGA”) is made and entered into this January 1, 2017, by and between the Board of County Commissioners, County of Adams (“County”), a political subdivision of the State of Colorado, located at 4330 South Adams County Parkway Brighton, Colorado 80601, and the City of Commerce City (“City”), located at 7887 East 60th Avenue, Commerce City, Colorado 80022.

WHEREAS, the Parties are authorized to enter into cooperative agreements pursuant to the Colorado Constitution, Article XIV, § 18, and § 29-1-203, C.R.S.; and,

WHEREAS, the Parties wish to enter into this IGA to enhance and continue cooperation between the Parties and to increase the availability of transit services in meeting a portion of the unmet transit needs of older adults and persons with disabilities in the unincorporated areas and municipalities within the County; and,

WHEREAS, the Parties, along with other municipalities, have formed the Adams County Community Transit Policy Council (“Policy Council”) to facilitate the development of special transit services within the County and the municipalities; and,

WHEREAS, the Policy Council has been responsible for the development of special transit services within the County and the municipalities, has assisted in the development of a budget, and has assisted in the review and selection of a transportation broker; and,

WHEREAS, the Policy Council has developed a budget that anticipates expenditures required for the continuation of special transit service delivery; and,

WHEREAS, the Policy Council will continue to facilitate the sharing of responsibility for providing special transit services among the County and the municipalities; and,

WHEREAS, the Parties and other municipalities intend to allocate funding on an annual basis for the Community Transit Program formed pursuant to the prior Intergovernmental Agreement with the City of Commerce City Concerning the Adams County Community Transit Program (“Original IGA”) and similar agreements with other municipalities; and,

WHEREAS, each of the Parties has agreed to appoint a representative and an alternate who can act on behalf of their jurisdiction to serve as a member of Policy Council.

NOW, THEREFORE, the Parties mutually agree as follows:

## **SECTION A - COMMUNITY TRANSIT PROGRAM SCOPE AND ADMINISTRATION**

The Community Transit Program shall consist of the continuation of special transit service delivery for eligible residents of Adams County. The Community Transit Program shall be carried out in accordance with the direction of the Policy Council and the Adams County Community Transit Program Manager.

### **Responsibilities of the Policy Council**

The Policy Council is comprised of one representative appointed by each municipal jurisdiction that funds the Community Transit Program and two appointed representatives of the Adams County Board of County Commissioners. The representatives will act on behalf of their jurisdiction and will have voting authority. Each municipal representative shall have an alternate who can attend Policy Council meetings in the representative's absence.

The Policy Council will be responsible for activities including, but not limited to, setting fares, establishing rider eligibility criteria, approving service delivery contracts, approving the annual budget, authorizing submission of grant applications and other funding requests, receiving public comments on services provided, and shall provide policy direction for the Community Transit Program.

### **Responsibilities of the County**

The administration, oversight and management of the Community Transit Program shall be provided by Adams County staff.

The County shall act as the contracting agency for the purposes of application of eligible local, State, and Federal transit funds for the Community Transit Program.

The County shall obtain all funding agency approvals and permits that are required or otherwise necessary to execute the Community Transit Program.

The County shall act as Fiscal Agent for such funds and be responsible for the disbursement of funds on behalf of all Parties.

The County shall provide necessary financial and performance reports and other information to the Policy Council as requested.

The County shall contract with a Transportation Broker to administer the Community Transit Program.

## **Responsibilities of the Transportation Broker**

The responsibilities of the Transportation Broker will include, but not be limited to, scheduling the most cost-effective trips, offering information and referral, and/or providing transportation services for all eligible residents in Adams County.

The Transportation Broker will provide Non-Title III transportation scheduling services and transportation for eligible residents who have mobility impairments, regardless of age, or who are sixty (60) years of age or over, including wheelchair bound older adults, to medical and dental appointments, grocery facilities and congregate meal sites.

If the actual service delivery deviates more than 5% in any category from the annual goals set by Council, the Transportation Broker shall brief the Policy Council and receive prior written authorization from the Community Transit Program Manager.

The Transportation Broker shall generally provide the trips on a scheduled or prearranged basis.

The Transportation Broker shall provide complete information and referral to eligible residents about available services and resources, including but not limited to, name, address and telephone number of other service or resource providers and/or provide the eligible resident with a referral to appropriate community resources to ensure that necessary services will be delivered.

The Transportation Broker will provide monthly performance reports to the Community Transit Program Manager that shall detail the following:

- The total number of trips provided
- Specify client type
- Specify the passenger's city or unincorporated place of residence
- Specify the passenger's destination location and city
- Identify the classification of the trip (congregate nutrition, medical/dental, grocery, or other)
- Specify the method of transportation used (taxi, bus, community wheels)
- Identify the funding account to be charged to pay for trip cost
- Identify the number of trips that were unable to be provided by jurisdiction and the reason trip was not provided
- A program income report

## SECTION B - TERM

The IGA commences on January 1, 2017, and shall automatically renew in successive one-year qualification periods, unless either Party provides written notice to terminate the IGA at least thirty days prior to the expiration of a given term.

## SECTION C - COMMUNITY TRANSIT PROGRAM FUNDING

The Community Transit Program's administrative and operating funds may be obtained from a variety of sources, including but not limited to: Regional Transportation District, Title III Older Americans Act, Denver Regional Council of Governments, participating local governments, and the Colorado Department of Transportation.

The City and County local government funds to be allocated to this project will be determined on an annual basis by a vote of the Adams County Community Transit Policy Council. The allocation and payment of any funds subject to this IGA shall be subject to annual appropriation by the governing bodies of the City and the County.

## SECTION D - REIMBURSEMENTS

If this IGA is terminated, all funds paid by the City or the County and not committed at the time of termination of this IGA shall be refunded.

## SECTION E - INSURANCE

The Parties shall each maintain insurance, in the form of a self-insurance program and/or insurance policies, to adequately insure the Party against any claims and/or damages that might arise as a result of its performance or failure to perform under this IGA.

## SECTION F - NO INDEMNIFICATION

Each Party agrees to be responsible for the actions of its officials and employees in the performance of this IGA. Nothing herein shall be deemed as a waiver by any party of the rights, immunities and limitations afforded each by the Colorado Governmental Immunity Act CRS 24-10-101, as amended, or otherwise available at law.

## SECTION G - TERMINATION FOR CAUSE

This IGA shall not be terminated by any Party for convenience but may only be terminated for cause (except for non-renewal). Cause for termination shall consist of either a failure by one of the Parties to perform pursuant to the terms of this IGA or a lack of available funding as described in Section C of the IGA. If termination is due to the failure of one of the Parties to perform pursuant to the terms of this IGA, the termination shall be effective thirty (30) days after written notice of the termination and cause(s) thereof have been given to the Parties, and the alleged non-performing Party has failed to cure the non-performance within the thirty (30) day period.

**SECTION H - NOTICE**

Any notices given under this IGA are deemed to have been received and to be effective: (a) three (3) days after the notice is mailed by certified mail, return receipt requested; (b) immediately upon hand delivery; or (c) immediately upon receipt of confirmation that a facsimile was received. For the purposes of this IGA, any and all notices shall be addressed to the contacts listed below:

To the County:

Adams County Board of County Commissioners  
4430 South Adams County Parkway 5<sup>th</sup> floor Suite  
C5000A  
Brighton, CO 80601  
Phone: 720-523-6100  
FAX: 720- 523-6045

Adams County Attorney's Office  
4430 South Adams County Parkway  
5<sup>th</sup> floor Suite C5000B  
Brighton, CO 80601  
Phone: 720- 523-6116  
FAX: 720-523-6114

Adams County Department of Human Services  
Community Transit Program Manager  
7190 Colorado Blvd.  
Commerce City, CO 80022  
Phone: (303) 227-2283  
FAX: (303) 227-2211

To the City:

City of Commerce City  
City Manager  
7887 East 60th Avenue  
Commerce City, Colorado 80022

City of Commerce City  
City Attorney  
7887 East 60th Avenue  
Commerce City, Colorado 80022

#### SECTION I - ASSIGNABILITY

Neither this IGA, nor any rights hereunder, in whole or in part, shall be assignable or otherwise transferable by the Parties without the prior written consent of all of the Parties.

#### SECTION J - VENUE AND JURISDICTION

The laws of the State of Colorado shall govern as to the interpretation, validity, and effect of this IGA. The Parties agree that jurisdiction and venue for any disputes arising under this IGA shall be in Adams County, Colorado.

#### SECTION K - INTEGRATION OF UNDERSTANDING

This IGA contains the entire understanding of the Parties, and neither it, nor the rights and obligations hereunder, may be changed, modified, or waived except by an instrument in writing that is signed by all of the Parties.

#### SECTION L - SEVERABILITY

If any provision of this IGA is determined to be unenforceable or invalid for any reason, the remainder of this IGA shall remain in effect, unless otherwise terminated in accordance with the terms contained herein.

#### SECTION M - AUTHORIZATION

Each Party represents and warrants that it has the power and ability to enter into this IGA, to grant the rights granted herein, and to perform the duties and obligations herein described.

#### SECTION N - RIGHTS OF THIRD PARTIES

This IGA does not and shall not be deemed to confer on any third party the right to the performance or proceeds under this IGA or to claim any damages or bring any legal action or other proceeding against the parties to this IGA for any breach or other failure to perform this IGA.

#### SECTION O – ORIGINAL IGA SUPERSEDED

This IGA supersedes and replaces the Original IGA and any amendments thereto.

#### SECTION P – NON-APPROPRIATION

The Parties will use their best efforts to appropriate funds sufficient to make the payment for each of their obligations as contemplated herein. However, if either Party fails to appropriate sufficient funds to make such payments or perform such obligations, the other Party shall have no remedy at law or in equity to enforce the terms of this IGA. The Parties agree and acknowledge that based on the foregoing and the Parties' ability to terminate this IGA, this IGA does not constitute a multiple fiscal year debt or financial obligation of any Party.

IN WITNESS WHEREOF, the Parties have caused their names to be affixed hereto.

CITY OF COMMERCE CITY,  
a Colorado municipal corporation

  
\_\_\_\_\_  
City Mayor

Date: 11-7-16

Attest (Seal)

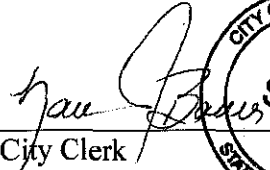
  
\_\_\_\_\_  
City Clerk



The seal is circular with the text "CITY OF COMMERCE CITY" around the top and "STATE OF COLORADO" around the bottom. In the center, the word "SEAL" is written in a bold, sans-serif font.

APPROVED AS TO FORM:

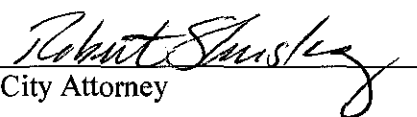
  
\_\_\_\_\_  
City Attorney

BOARD OF COUNTY  
COMMISSIONERS  
ADAMS COUNTY, COLORADO

\_\_\_\_\_  
Chairperson

Date: \_\_\_\_\_

Attest (Seal)

Clerk  
Board of County Commissioners

\_\_\_\_\_  
Deputy Clerk

APPROVED AS TO FORM:

  
\_\_\_\_\_  
Adams County Attorney's Office

INTERGOVERNMENTAL AGREEMENT WITH THE CITY OF NORTHGLENN  
CONCERNING THE ADAMS COUNTY  
COMMUNITY TRANSIT PROGRAM (a.k.a. ALIFT)

THIS INTERGOVERNMENTAL AGREEMENT ("IGA") is made and entered into this \_\_\_\_\_ day of \_\_\_\_\_, 2016 by and between the Board of County Commissioners, County of Adams ("County"), a political subdivision of the State of Colorado, located at 4330 South Adams County Parkway Brighton, Colorado 80601, and the City of Northglenn ("City"), located at 11701 Community Center Drive, Northglenn, Colorado 80233.

WHEREAS, the Parties are authorized to enter into cooperative agreements pursuant to the Colorado Constitution, Article XIV, § 18, and § 29-1-203, C.R.S.; and

WHEREAS, the Parties entered into an intergovernmental agreement dated May 13, 2004, concerning the Adams County Community Transit Program (the "2004 IGA"); and

WHEREAS, the Parties wish to enter into this IGA to enhance cooperation between the Parties and to increase the availability of transit services in meeting a portion of the unmet transit needs of older adults and persons with disabilities in the unincorporated areas and municipalities within the County; and

WHEREAS, the Parties have formed the Adams County Community Transit Policy Council ("Policy Council") to facilitate the development of special transit services within the County and the municipalities; and

WHEREAS, the Policy Council has been responsible for the development of special transit services within the County and the municipalities, has assisted in the development of a budget, and has assisted in the review and selection of a transportation broker; and

WHEREAS, the Policy Council has developed a budget that anticipates expenditures required for the continuation of special transit service delivery; and

WHEREAS, the Policy Council will continue to facilitate the sharing of responsibility for providing special transit services among the County and the municipalities; and

WHEREAS, the Parties have agreed to allocate funding on an annual basis for the Community Transit Program; and

WHEREAS, each of the Parties has agreed to appoint a representative and an alternate who can act on behalf of their jurisdiction to serve as a member of Policy Council.

NOW, THEREFORE, the Parties mutually agree as follows:

**I. SECTION A – COMMUNITY TRANSIT PROGRAM SCOPE AND ADMINISTRATION**

1) Scope:

This Community Transit Program shall consist of the continuation of special transit



service delivery for eligible residents of Adams County. The Community Transit Program shall be carried out in accordance with the direction of the Policy Council and the Adams County Community Transit Program Manager.

2) Administration:

a. Responsibilities of the Policy Council:

1. The Policy Council is comprised of one representative appointed by each municipal jurisdiction that funds the Community Transit Program and two appointed representatives of the Adams County Board of County Commissioners. The representatives will act on behalf of their jurisdiction and will have voting authority. Each municipal representative shall have an alternate who can attend Policy Council meetings in the representative's absence.

2. The Policy Council will be responsible for activities including, but not limited to, setting fares, establishing rider eligibility criteria, approving service delivery contracts, approving the annual budget, authorizing submission of grant applications and other funding requests, receiving public comments on services provided, and shall provide policy direction for the Community Transit Program.

b. Responsibilities of the County:

1. The administration, oversight and management of the Community Transit Program shall be provided by Adams County staff.

2. The County shall act as the contracting agency for the purposes of application of eligible local, State, and Federal transit funds for the Community Transit Program.

3. The County shall obtain all funding agency approvals and permits that are required or otherwise necessary to execute the Community Transit Program.

4. The County shall act as Fiscal Agent for such funds and be responsible for the disbursement of funds on behalf of all Parties.

5. The County shall provide necessary financial and performance reports and other information to the Policy Council as requested.

6. The County shall contract with a Transportation Broker to administer the Community Transit Program.

c. Responsibilities of the Transportation Broker:

1. The responsibilities of the Transportation Broker will include, but not be limited to, scheduling the most cost-effective trips, offering information and referral, and/or providing transportation services for all eligible residents in Adams County.

2. The Transportation Broker will provide Non-Title III transportation scheduling services and transportation for eligible residents who have mobility impairments, regardless of age, or who are sixty (60) years of age or over, including wheelchair bound older adults, to medical and dental appointments, grocery facilities and congregate meal sites.

3. If the actual service delivery deviates more than 5% in any category from the annual goals set by Council, the Transportation Broker shall brief the Policy Council and receive prior written authorization from the Community Transit Program Manager.

4. The Transportation Broker shall generally provide the trips on a scheduled or prearranged basis.

5. The Transportation Broker shall provide complete information and referral to eligible residents about available services and resources, including but not limited to, name, address and telephone number of other service or resource providers and/or provide the eligible resident with a referral to appropriate community resources to ensure that necessary services will be delivered.

6. The Transportation Broker will provide monthly performance reports to the Community Transit Program Manager that shall detail the following:

- The total number of trips provided
- Specify client type
- Specify the passenger's city or unincorporated place of residence
- Specify the passenger's destination location and city
- Identify the classification of the trip (congregate nutrition, medical/dental, grocery, or other)
- Specify the method of transportation used (taxi, bus, community wheels)
- Identify the funding account to be charged to pay for trip cost
- Identify the number of trips that were unable to be provided by jurisdiction and the reason trip was not provided
- A program income report

## **II. SECTION B – TERM**

The IGA commences on January 1, 2017 and shall automatically renew in successive one-year qualification periods, unless either party provides written notice to terminate the IGA at least thirty days prior to the expiration of a given term. On such commencement date the 2004 IGA shall terminate and shall be of no force or effect.

## **III. SECTION C – COMMUNITY TRANSIT PROGRAM FUNDING**

The Community Transit Program's administrative and operating funds may be obtained from a variety of sources, including but not limited to: Regional Transportation District, Title III

Older Americans Act, Denver Regional Council of Governments, participating local governments, and the Colorado Department of Transportation.

The City and County local government funds allocated to this project will be determined on an annual basis by a vote of the Adams County Community Transit Policy Council and subject to annual appropriation by the governing body of the City and the County.

**IV. SECTION D – REIMBURSEMENTS**

In the event this IGA is terminated, all funds paid by the City or the County and not committed at the time of termination of this IGA shall be refunded.

**V. SECTION E – INSURANCE**

The Parties shall each maintain insurance, in the form of a self-insurance program and/or insurance policies, to adequately insure the Party against any claims and/or damages that might arise as a result of its performance or failure to perform under this IGA.

**VI. SECTION F – NO INDEMNIFICATION**

Each Party agrees to be responsible for the actions of its officials and employees in the performance of this IGA. Nothing herein shall be deemed as a waiver by any party of the rights, immunities and limitations afforded each by the Colorado Governmental Immunity Act CRS 24-10-101, as amended, or otherwise available at law.

**VII. SECTION G – TERMINATION FOR CAUSE**

This IGA shall not be terminated by any Party for convenience but may only be terminated for cause. Cause for termination shall consist of either a failure by one of the Parties to perform pursuant to the terms of this IGA, or a lack of available funding as described in Section C of the IGA. If termination is due to the failure of one of the Parties to perform pursuant to the terms of this IGA, the termination shall be effective thirty (30) days after written notice of the termination and cause(s) thereof have been given to the Parties, and the alleged non-performing Party has failed to cure the non-performance within the thirty (30) day period.

**VIII. SECTION H – NOTICE**

Any notices given under this IGA are deemed to have been received and to be effective: (a) three (3) days after the notice is mailed by certified mail, return receipt requested; (b) immediately upon hand delivery; or (c) immediately upon receipt of confirmation that an email or facsimile was received. For the purposes of this IGA, any and all notices shall be addressed to the contacts listed below:

Adams County Board of County Commissioners:

4430 South Adams County Parkway, 5th Floor, Suite C5000A  
Brighton, CO 80601  
Phone: 720-523-6100  
FAX: 720- 523-6045

Adams County Attorney's Office:

4430 South Adams County Parkway, 5th Floor, Suite C5000B  
Brighton, CO 80601  
Phone: 720- 523-6116  
FAX: 720-523-6114

Adams County Department of Human Services:

Community Transit Program Manager  
7190 Colorado Blvd.  
Commerce City, CO 80022  
Phone: (303) 227-2283  
FAX: (303) 227-2211

City of Northglenn:

11701 Community Center Drive  
Northglenn, Colorado 80233

**IX. SECTION I – ASSIGNABILITY**

Neither this IGA, nor any rights hereunder, in whole or in part, shall be assignable or otherwise transferable by the Parties without the prior written consent of all of the Parties.

**X. SECTION J – VENUE AND JURISDICTION**

The laws of the State of Colorado shall govern as to the interpretation, validity, and effect of this IGA. The Parties agree that jurisdiction and venue for any disputes arising under this IGA shall be in Adams County, Colorado.

**XI. SECTION K – INTEGRATION OF UNDERSTANDING**

This IGA contains the entire understanding of the Parties, and neither it, nor the rights and obligations hereunder, may be changed, modified, or waived except by an instrument in writing that is signed by all of the Parties.

**XII. SECTION L – SEVERABILITY**

If any provision of this IGA is determined to be unenforceable or invalid for any reason, the remainder of this IGA shall remain in effect, unless otherwise terminated in accordance with the terms contained herein.

**XIII. SECTION M – AUTHORIZATION**

Each Party represents and warrants that it has the power and ability to enter into this IGA, to grant the rights granted herein, and to perform the duties and obligations herein described.

**XIV. SECTION N – RIGHTS OF THIRD PARTIES**

This IGA does not and shall not be deemed to confer on any third party the right to the performance or proceeds under this IGA or to claim any damages or bring any legal action or other proceeding against the parties to this IGA for any breach or other failure to perform this IGA.

IN WITNESS WHEREOF, the Parties have caused their names to be affixed hereto.

DATED this \_\_\_\_\_ day of \_\_\_\_\_, 2016.

CITY OF NORTHGLENN,  
a Colorado municipal corporation

BOARD OF COUNTY COMMISSIONERS  
ADAMS COUNTY, COLORADO

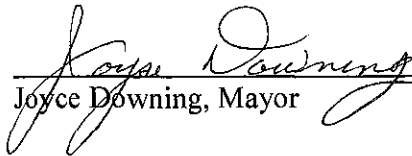
  
\_\_\_\_\_  
Joyce Downing, Mayor

\_\_\_\_\_  
Chairperson

Attest (Seal)

Attest (Seal)  
Clerk, Board of County Commissioners

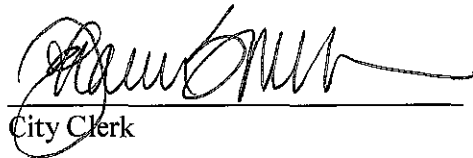
  
\_\_\_\_\_  
City Clerk

\_\_\_\_\_  
Deputy Clerk

APPROVED AS TO FORM:

APPROVED AS TO FORM:

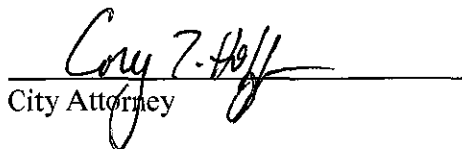
  
\_\_\_\_\_  
City Attorney

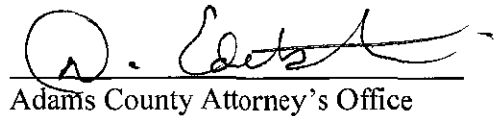
  
\_\_\_\_\_  
Adams County Attorney's Office

INTERGOVERNMENTAL AGREEMENT WITH THE CITY OF THORNTON  
CONCERNING THE ADAMS COUNTY COMMUNITY  
TRANSIT PROGRAM (a.k.a. ALIFT)

THIS INTERGOVERNMENTAL AGREEMENT ("IGA") is made and entered into this \_\_\_\_\_ day of \_\_\_\_\_, 2017 by and between the Board of County Commissioners ("BOCC"), County of Adams ("County"), a political subdivision of the State of Colorado, located at 4330 South Adams County Parkway, Brighton, Colorado 80601, and the City of Thornton ("City"), located at 9500 Civic Center Drive, Thornton, Colorado 80229.

WHEREAS, the Parties are authorized to enter into cooperative agreements pursuant to the Colorado Constitution, Article XIV, § 18, and § 29-1-203, C.R.S.; and,

WHEREAS, the Parties wish to enter into this IGA to enhance cooperation between the Parties and to increase the availability of transit services in meeting a portion of the unmet transit needs of older adults and persons with disabilities in the unincorporated areas and municipalities within the County; and,

WHEREAS, the Parties have formed the Adams County Community Transit Policy Council ("Policy Council") to facilitate the development of special transit services within the County and the municipalities; and,

WHEREAS, the Policy Council has been responsible for the development of special transit services within the County and the municipalities, has assisted in the development of a budget, and has assisted in the review and selection of a transportation broker; and,

WHEREAS, the Policy Council has developed a budget that anticipates expenditures required for the continuation of special transit service delivery; and,

WHEREAS, the Policy Council will continue to facilitate the sharing of responsibility for providing special transit services among the County and the municipalities; and,

WHEREAS, the Parties have agreed to allocate funding on an annual basis for the Community Transit Program; and,

WHEREAS, each of the Parties has agreed to appoint a representative and an alternate whom can act on behalf of their jurisdiction to serve as a member of Policy Council.

NOW, THEREFORE, the Parties mutually agree as follows:

SECTION A - COMMUNITY TRANSIT PROGRAM SCOPE AND ADMINISTRATION

This Community Transit Program shall consist of the continuation of special transit service delivery for eligible residents of Adams County. The Community Transit Program shall be carried out in accordance with the direction of the Policy Council and the Adams County Community Transit Program Manager.

Responsibilities of the Policy Council

The Policy Council is comprised of one representative appointed by each municipal jurisdiction that funds the Community Transit Program and two appointed representatives of the Adams County Board of County Commissioners. The representatives will act on behalf of their jurisdiction and will have voting authority. Each municipal representative shall have an alternate who can attend Policy Council meetings in the representative's absence.

The Policy Council will be responsible for activities including, but not limited to, setting fares, establishing rider eligibility criteria, approving service delivery contracts, approving the annual budget, authorizing submission of grant applications and other funding requests, receiving public comments on services provided, and shall provide policy direction for the Community Transit Program.

Responsibilities of the County

The administration, oversight and management of the Community Transit Program shall be provided by Adams County staff.

The County shall act as the contracting agency for the purposes of application of eligible local, State, and Federal transit funds for the Community Transit Program.

The County shall obtain all funding agency approvals and permits that are required or otherwise necessary to execute the Community Transit Program.

The County shall act as Fiscal Agent for such funds and be responsible for the disbursement of funds on behalf of all Parties.

The County shall provide necessary financial and performance reports and other information to the Policy Council as requested.

The County shall contract with a Transportation Broker to administer the Community Transit Program.

## Responsibilities of the Transportation Broker

The responsibilities of the Transportation Broker will include, but not be limited to, scheduling the most cost-effective trips, offering information and referral, and/or providing transportation services for all eligible residents in Adams County.

The Transportation Broker will provide transportation scheduling services and transportation for eligible residents who have mobility impairments, regardless of age, or who are sixty (60) years of age or over, including wheelchair bound older adults, to medical and dental appointments, grocery facilities and congregate meal sites.

If the actual service delivery deviates more than 5% in any category from the annual goals set by Council, the Transportation Broker shall brief the Policy Council and receive prior written authorization from the Community Transit Program Manager.

The Transportation Broker shall generally provide the trips on a scheduled or prearranged basis.

The Transportation Broker shall provide complete information and referral to eligible residents about available services and resources, including but not limited to, name, address, and telephone number of other service or resource providers, and/or provide the eligible resident with a referral to appropriate community resources to ensure that necessary services will be delivered.

The Transportation Broker will provide monthly performance reports to the Community Transit Program Manager that shall detail the following:

- The total number of trips provided
- Specify client type
- Specify the passenger's city or unincorporated place of residence
- Specify the passenger's destination location and city
- Identify the classification of the trip (congregate nutrition, medical/dental, grocery, or other)
- Specify the method of transportation used (taxi, bus, community wheels)
- Identify the funding account to be charged to pay for trip cost
- Identify the number of trips that were unable to be provided by jurisdiction and the reason trip was not provided
- A program income report



## SECTION B - TERM

The IGA commences on the date first above written and shall automatically renew in successive one-year qualification periods, unless either party provides written notice to terminate the IGA at least thirty days prior to the expiration of a given term.

## SECTION C - COMMUNITY TRANSIT PROGRAM FUNDING

The Community Transit Program's administrative and operating funds may be obtained from a variety of sources, including but not limited to: Regional Transportation District, Title III Older Americans Act, Denver Regional Council of Governments, participating local governments, and the Colorado Department of Transportation.

The City and County local government funds allocated to this project will be determined on an annual basis by a vote of the Adams County Community Transit Policy Council and subject to annual appropriation by the governing body of the City and the County.

## SECTION D - REIMBURSEMENTS

In the event this IGA is terminated, all funds paid by the City or the County and not committed at the time of termination of this IGA shall be refunded.

## SECTION E - INSURANCE

The Parties shall each maintain insurance, in the form of a self-insurance program and/or insurance policies, to adequately insure the Party against any claims and/or damages that might arise as a result of its performance or failure to perform under this IGA.

## SECTION F - NO INDEMNIFICATION

Each Party agrees to be responsible for the actions of its officials and employees in the performance of this IGA. Nothing herein shall be deemed as a waiver by any party of the rights, immunities and limitations afforded each by the Colorado Governmental Immunity Act CRS 24-10-101, as amended, or otherwise available at law.

## SECTION G - TERMINATION FOR CAUSE

This IGA shall not be terminated by any Party for convenience but may only be terminated for cause. Cause for termination shall consist of either a failure by one of the Parties to perform pursuant to the terms of this IGA, or a lack of available funding as described in Section C of the IGA. If termination is due to the failure of one of the Parties to perform, pursuant to the terms of this IGA, the termination shall be effective thirty (30) days after written notice of the termination and cause(s) thereof have been given to the Parties, and the alleged non-performing Party has failed to cure the non-performance within the thirty (30) day period.

**SECTION H - NOTICE**

Any notices given under this IGA are deemed to have been received and to be effective: (a) three (3) days after the notice is mailed by certified mail, return receipt requested; (b) immediately upon hand delivery; or (c) immediately upon receipt of confirmation that a facsimile was received. For the purposes of this IGA, any and all notices shall be addressed to the contacts listed below:

Adams County Board of County  
Commissioners  
4430 South Adams County Parkway  
5<sup>th</sup> floor Suite C5000A  
Brighton, CO 80601  
Phone: 720-523-6100  
FAX: 720- 523-6045

Adams County Attorney's Office  
4430 South Adams County Parkway  
5<sup>th</sup> floor Suite C5000B  
Brighton, CO 80601  
Phone: 720-523-6116  
FAX: 720-523-6114

Adams County Department of Human Services  
Community Transit Program Manager

7190 Colorado Blvd.  
Commerce City, CO  
80022  
Phone: (303) 227-2283  
FAX: (303) 227-2211

City of Thornton  
City Manager's Office  
9500 Civic Center Drive  
Thornton, Colorado  
80229  
Phone: (303) 538-7200  
FAX: (303) 538-7562

**SECTION I - ASSIGNABILITY**

Neither this IGA, nor any rights hereunder, in whole or in part, shall be assignable or otherwise transferable by the Parties without the prior written consent of all of the Parties.

**SECTION J - VENUE AND JURISDICTION**

The laws of the State of Colorado shall govern as to the interpretation, validity, and effect of this IGA. The Parties agree that jurisdiction and venue for any disputes arising under this IGA shall be in Adams County, Colorado.

**SECTION K - INTEGRATION OF UNDERSTANDING**

This IGA contains the entire understanding of the Parties, and neither it, nor the rights and obligations hereunder, may be changed, modified, or waived except by an instrument in writing that is signed by all of the Parties.

**SECTION L - SEVERABILITY**

If any provision of this IGA is determined to be unenforceable or invalid for any reason, the remainder of this IGA shall remain in effect, unless otherwise terminated in accordance with the terms contained herein.

**SECTION M - AUTHORIZATION**

Each Party represents and warrants that it has the power and ability to enter into this IGA, to grant the rights granted herein, and to perform the duties and obligations herein described.

**SECTION N - RIGHTS OF THIRD PARTIES**

This IGA does not and shall not be deemed to confer on any third party the right to the performance or proceeds under this IGA or to claim any damages or bring any legal action or other proceeding against the parties to this IGA for any breach or other failure to perform this IGA.

IN WITNESS WHEREOF, the Parties have caused their names to be affixed hereto.

DATED this \_\_\_\_\_ day of 2017

CITY OF THORNTON,  
a Colorado municipal corporation

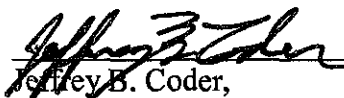
  
\_\_\_\_\_  
Jeffrey B. Coder,  
Acting City Manager

Attest (Seal)

  
\_\_\_\_\_  
Kristen N. Rosenbaum,  
City Clerk

APPROVED AS TO FORM:  
Luis A. Corchado, City Attorney

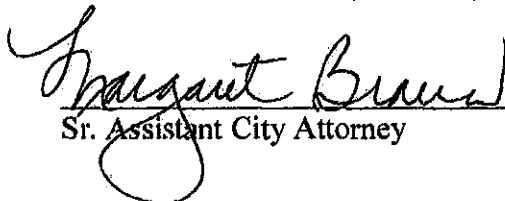
  
\_\_\_\_\_  
Sr. Assistant City Attorney

BOARD OF COUNTY COMMISSIONERS  
ADAMS COUNTY, COLORADO

\_\_\_\_\_  
Chairperson

Attest (Seal)  
Clerk  
Board of County Commissioners

\_\_\_\_\_  
Deputy Clerk

APPROVED AS TO FORM:

  
\_\_\_\_\_  
Adams County Attorney's Office

**RESOLUTION**

**A RESOLUTION APPROVING AN INTERGOVERNMENTAL AGREEMENT BETWEEN THE CITY OF THORNTON AND ADAMS COUNTY CONCERNING A-LIFT, THE ADAMS COUNTY COMMUNITY TRANSIT PROGRAM FOR SENIORS AND THE DISABLED.**

**WHEREAS, the City of Thornton and Adams County are authorized to enter into cooperative agreements pursuant to the Colorado Constitution, Article XIV, § 18, and § 29-1-203, C.R.S.; and**

**WHEREAS, the Parties wish to enter into this intergovernmental agreement (IGA) to enhance cooperation between the Parties and increase the availability of transit services for a portion of the unmet transit needs of older adults and persons with disabilities in the unincorporated areas and municipalities within the County; and**

**WHEREAS, the Parties have formed the Adams County Community Transit Policy Council ("Policy Council") to facilitate the development of special transit services within the County and the municipalities; and**

**WHEREAS, the Policy Council has been responsible for the development of special transit services within the County and the municipalities, has assisted in the development of a budget, and has assisted in the review and selection of a transportation broker; and**

**WHEREAS, the Policy Council has developed a budget that anticipates expenditures required for the continuation of special transit service delivery; and**

**WHEREAS, the Policy Council will continue to facilitate the sharing of responsibility for providing special transit services among the County and the municipalities; and**

**WHEREAS, the Parties have agreed to allocate funding on an annual basis for the Community Transit Program; and**

**WHEREAS, each of the Parties has agreed to appoint a representative and an alternate who can act on behalf of their jurisdiction to serve as a member of the Policy Council.**

**NOW, THEREFORE, BE IT RESOLVED BY THE CITY COUNCIL OF THE CITY OF THORNTON, COLORADO, AS FOLLOWS:**

- 1. That the City Council hereby approves the intergovernmental agreement attached hereto and incorporated herein by this reference. The City Manager is hereby authorized to execute and the City Clerk to attest said intergovernmental agreement between the City of Thornton and Adams County**

regarding A-Lift, the Adams County Community Transit Program for seniors and the disabled.

2. That the City Manager is hereby authorized to execute on behalf of the City any successive agreements upon substantially the same terms and conditions as contained in this intergovernmental agreement.
3. That the intergovernmental agreement shall not be in full force and effect until signed by both parties.

PASSED AND ADOPTED at a regular meeting of the City Council of the City of Thornton, Colorado, on January 24, 2017.

CITY OF THORNTON, COLORADO

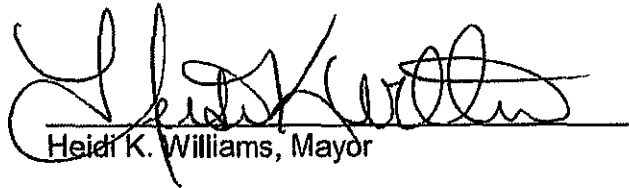

Heidi K. Williams, Mayor

ATTEST:

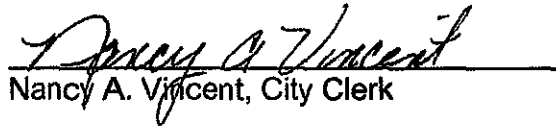

Nancy A. Vincent, City Clerk

INTERGOVERNMENTAL AGREEMENT WITH THE CITY OF WESTMINSTER  
CONCERNING THE ADAMS COUNTY COMMUNITY  
TRANSIT PROGRAM (a.k.a. ALIFT)

THIS INTERGOVERNMENTAL AGREEMENT ("IGA") is made and entered into this \_\_\_\_\_ day of \_\_\_\_\_, 2017 by and between the Board of County Commissioners ("BOCC"), County of Adams ("County"), a political subdivision of the State of Colorado, located at 4330 South Adams County Parkway, Brighton, Colorado 80601, and the City of Westminster ("City"), located at 4800 West 92nd Avenue, Westminster, CO 80031.

WHEREAS, the Parties are authorized to enter into cooperative agreements pursuant to the Colorado Constitution, Article XIV, § 18, and § 29-1-203, C.R.S.; and,

WHEREAS, the Parties wish to enter into this IGA to enhance cooperation between the Parties and to increase the availability of transit services in meeting a portion of the unmet transit needs of older adults and persons with disabilities in the unincorporated areas and municipalities within the County; and,

WHEREAS, the Parties have formed the Adams County Community Transit Policy Council ("Policy Council") to facilitate the development of special transit services within the County and the municipalities; and,

WHEREAS, the Policy Council has been responsible for the development of special transit services within the County and the municipalities, has assisted in the development of a budget, and has assisted in the review and selection of a transportation broker; and,

WHEREAS, the Policy Council has developed a budget that anticipates expenditures required for the continuation of special transit service delivery; and,

WHEREAS, the Policy Council will continue to facilitate the sharing of responsibility for providing special transit services among the County and the municipalities; and,

WHEREAS, the Parties have agreed to allocate funding on an annual basis for the Community Transit Program; and,

WHEREAS, each of the Parties has agreed to appoint a representative and an alternate who can act on behalf of their jurisdiction to serve as a member of Policy Council.

NOW, THEREFORE, the Parties mutually agree as follows:

SECTION A - COMMUNITY TRANSIT PROGRAM SCOPE AND ADMINISTRATION

This Community Transit Program shall consist of the continuation of special transit service delivery for eligible residents of Adams County. The Community Transit Program shall be carried out in accordance with the direction of the Policy Council and the Adams County Community Transit Program Manager.

Responsibilities of the Policy Council

The Policy Council is comprised of one representative appointed by each municipal jurisdiction that funds the Community Transit Program and two appointed representatives of the Adams County Board of County Commissioners. The representatives will act on behalf of their jurisdiction and will have voting authority. Each municipal representative shall have an alternate who can attend Policy Council meetings in the representative's absence.

The Policy Council will be responsible for activities including, but not limited to, setting fares, establishing rider eligibility criteria, approving service delivery contracts, approving the annual budget, authorizing submission of grant applications and other funding requests, receiving public comments on services provided, and shall provide policy direction for the Community Transit Program.

Responsibilities of the County

The administration, oversight and management of the Community Transit Program shall be provided by Adams County staff.

The County shall act as the contracting agency for the purposes of application of eligible local, State, and Federal transit funds for the Community Transit Program.

The County shall obtain all funding agency approvals and permits that are required or otherwise necessary to execute the Community Transit Program.

The County shall act as Fiscal Agent for such funds and be responsible for the disbursement of funds on behalf of all Parties.

The County shall provide necessary financial and performance reports and other information to the Policy Council as requested.

The County shall contract with a Transportation Broker to administer the Community Transit Program.



## Responsibilities of the Transportation Broker

The responsibilities of the Transportation Broker will include, but not be limited to, scheduling the most cost-effective trips, offering information and referral, and/or providing transportation services for all eligible residents in Adams County.

The Transportation Broker will provide transportation scheduling services and transportation for eligible residents who have mobility impairments, regardless of age, or who are sixty (60) years of age or over, including wheelchair bound older adults, to medical and dental appointments, grocery facilities, and congregate meal sites.

If the actual service delivery deviates more than 5% in any category from the annual goals set by Policy Council, the Transportation Broker shall brief the Policy Council and receive prior written authorization from the Community Transit Program Manager.

The Transportation Broker shall generally provide the trips on a scheduled or prearranged basis.

The Transportation Broker shall provide complete information and referral to eligible residents about available services and resources, including but not limited to, name, address, and telephone number of other service or resource providers, and/or provide the eligible resident with a referral to appropriate community resources to ensure that necessary services will be delivered.

The Transportation Broker will provide monthly performance reports to the Community Transit Program Manager that shall detail the following:

- The total number of trips provided
- Specify client type
- Specify the passenger's city or unincorporated place of residence
- Specify the passenger's destination location and city
- Identify the classification of the trip (congregate nutrition, medical/dental, grocery, or other)
- Specify the method of transportation used (taxi, bus, community wheels)
- Identify the funding account to be charged to pay for trip cost
- Identify the number of trips that were unable to be provided by jurisdiction and the reason trip was not provided
- A program income report

SECTION B - TERM

The IGA commences on \_\_\_\_\_ and shall automatically renew in successive one-year qualification periods, unless either party provides written notice to terminate the IGA at least thirty days prior to the expiration of a given term.

SECTION C - COMMUNITY TRANSIT PROGRAM FUNDING

The Community Transit Program's administrative and operating funds may be obtained from a variety of sources, including but not limited to: Regional Transportation District, Title III Older Americans Act, Denver Regional Council of Governments, participating local governments, and the Colorado Department of Transportation.

The City and County local government funds allocated to this project will be determined on an annual basis by a vote of the Adams County Community Transit Policy Council and subject to annual appropriation by the governing body of the City and the County.

SECTION D - REIMBURSEMENTS

In the event this IGA is terminated, all funds paid by the City or the County and not committed at the time of termination of this IGA shall be refunded.

SECTION E - INSURANCE

The Parties shall each maintain insurance, in the form of a self-insurance program and/or insurance policies, to adequately insure the Party against any claims and/or damages that might arise as a result of its performance or failure to perform under this IGA.

SECTION F - NO INDEMNIFICATION

Each Party agrees to be responsible for the actions of its officials and employees in the performance of this IGA. Nothing herein shall be deemed as a waiver by any party of the rights, immunities and limitations afforded each by the Colorado Governmental Immunity Act CRS 24-10-101, as amended, or otherwise available at law.

SECTION G - TERMINATION FOR CAUSE

This IGA shall not be terminated by any Party for convenience but may only be terminated for cause or notice pursuant to Section B. Cause for termination shall consist of either a failure by one of the Parties to perform pursuant to the terms of this IGA, or a lack of available funding as described in Section C of the IGA. If termination is due to the failure of one of the Parties to perform pursuant to the terms of this IGA, the termination shall be effective thirty (30) days after written notice of the termination and cause(s) thereof have been given to the Parties, and the alleged non-performing Party has failed to cure the non-performance within the thirty (30) day period.

SECTION H - NOTICE

Any notices given under this I G A are deemed to have been received and to be effective: (a) three (3) days after the notice is mailed by certified mail, return receipt requested; (b) immediately upon hand delivery; or (c) immediately upon receipt of confirmation that a facsimile was received. For the purposes of this IGA, any and all notices shall be addressed to the contacts listed below:

Adams County Board of County  
Commissioners  
4430 South Adams County Parkway 5<sup>th</sup> floor  
Suite C5000A  
Brighton, CO 80601  
Phone: 720-523-6100  
FAX: 720- 523-6045

Adams County Attorney's Office  
4430 South Adams County Parkway  
5<sup>th</sup> floor Suite C5000B  
Brighton, CO 80601  
Phone: 720-523-6116  
FAX: 720-523-6114

Adams County Department of Human Services  
Community Transit Program Manager  
7190 Colorado Blvd.  
Commerce City, CO  
80022  
Phone: (303) 227-2283  
FAX: (303) 227-2211

City of Westminster,  
Colorado

\_\_\_\_\_  
\_\_\_\_\_  
\_\_\_\_\_  
\_\_\_\_\_  
\_\_\_\_\_

#### SECTION I - ASSIGNABILITY

Neither this IGA, nor any rights hereunder, in whole or in part, shall be assignable or otherwise transferable by the Parties without the prior written consent of all of the Parties.

#### SECTION J - VENUE AND JURISDICTION

The laws of the State of Colorado shall govern as to the interpretation, validity, and effect of this IGA. The Parties agree that jurisdiction and venue for any disputes arising under this IGA shall be in Adams County, Colorado.

#### SECTION K - INTEGRATION OF UNDERSTANDING

This IGA contains the entire understanding of the Parties, and neither it, nor the rights and obligations hereunder, may be changed, modified, or waived except by an instrument in writing that is signed by all of the Parties.

#### SECTION L - SEVERABILITY

If any provision of this IGA is determined to be unenforceable or invalid for any reason, the remainder of this IGA shall remain in effect, unless otherwise terminated in accordance with the terms contained herein.

#### SECTION M - AUTHORIZATION

Each Party represents and warrants that it has the power and ability to enter into this IGA, to grant the rights granted herein, and to perform the duties and obligations herein described.

#### SECTION N - RIGHTS OF THIRD PARTIES

This IGA does not and shall not be deemed to confer on any third party the right to the performance or proceeds under this IGA or to claim any damages or bring any legal action or other proceeding against the parties to this IGA for any breach or other failure to perform this IGA.

IN WITNESS WHEREOF, the Parties have caused their names to be affixed hereto.

DATED this \_\_\_\_\_ day of \_\_\_\_\_, 2017

CITY OF WESTMINSTER,  
a Colorado municipal corporation

BOARD OF COUNTY  
COMMISSIONERS  
ADAMS COUNTY, COLORADO

\_\_\_\_\_  
City Mayor

\_\_\_\_\_  
Chairperson

4800 West 92nd Avenue  
Westminster, CO 80031

Attest (Seal)

Attest (Seal)  
Clerk  
Board of County Commissioners

\_\_\_\_\_  
City Clerk

\_\_\_\_\_  
Deputy Clerk

APPROVED AS TO FORM:

APPROVED AS TO FORM:

\_\_\_\_\_  
City Attorney

\_\_\_\_\_  
Adams County Attorney's Office

**ADAMS COUNTY SIGNATURE PAGE**

**BOARD OF COUNTY COMMISSIONERS  
ADAMS COUNTY, COLORADO**

---

Chair

Date

ATTEST:  
JOSH ZYGIELBAUM  
CLERK AND RECORDER

Approved as to form:

---

Deputy Clerk Adams County Attorney's Office



## PUBLIC HEARING AGENDA ITEM

<b>DATE OF PUBLIC HEARING:</b> February 23, 2021
<b>SUBJECT:</b> Resolution approving right-of-way agreement between Adams County and Hillen Holdings, LLC, for property necessary for the Dahlia Street Roadway and Drainage Improvements Project from East 74 <sup>th</sup> Avenue to East 78 <sup>th</sup> Avenue
<b>FROM:</b> Kristin Sullivan, AICP, Director of Public Works Brian Staley, P.E., PTOE, Deputy Director of Public Works
<b>AGENCY/DEPARTMENT:</b> Public Works
<b>HEARD AT STUDY SESSION ON:</b> N/A
<b>AUTHORIZATION TO MOVE FORWARD:</b> <input type="checkbox"/> YES <input type="checkbox"/> NO
<b>RECOMMENDED ACTION:</b> That the Board of County Commissioners approves the right-of-way agreement for acquisition of property interests needed for the Dahlia Street Roadway and Drainage Improvements Project.

### **BACKGROUND:**

Adams County is in the process of acquiring property interests along the Dahlia Street corridor from East 74<sup>th</sup> Avenue to East 78<sup>th</sup> Avenue for the Dahlia Street Roadway and Drainage Improvement Project. The intention of this Project is to identify and improve the overall roadway and drainage of Dahlia Street. Attached is a copy of the right-of-way agreement between Adams County and Hillen Holdings, LLC, for the conveyance of the temporary construction easement, compensation for landscaping and signage in the amount of \$288,816.00. The attached resolution allows the County to acquire ownership of the property interests needed for construction purposes and provide the necessary documents to close on the property interest.

### **AGENCIES, DEPARTMENTS OR OTHER OFFICES INVOLVED:**

Adams County Public Works, Office of the County Attorney and Adams County Board of County Commissioners.

### **ATTACHED DOCUMENTS:**

Draft resolution  
Right-of-way agreement

**FISCAL IMPACT:**

Please check if there is no fiscal impact . If there is fiscal impact, please fully complete the section below.

<b>Fund: 13</b>
<b>Cost Center: 3056</b>

	<b>Object Account</b>	<b>Subledger</b>	<b>Amount</b>
Current Budgeted Revenue:			
Additional Revenue not included in Current Budget:			
<b>Total Revenues:</b>			<u>                    </u>

	<b>Object Account</b>	<b>Subledger</b>	<b>Amount</b>
Current Budgeted Operating Expenditure:	9135	30562101	\$15,000,000
Add'l Operating Expenditure not included in Current Budget:			
Current Budgeted Capital Expenditure:			
Add'l Capital Expenditure not included in Current Budget:			
<b>Total Expenditures:</b>			<u><b>\$15,000,000</b></u>

New FTEs requested:             YES             NO

Future Amendment Needed:     YES             NO

**Additional Note:**



BOARD OF COUNTY COMMISSIONERS FOR  
ADAMS COUNTY, STATE OF COLORADO

RESOLUTION APPROVING RIGHT-OF-WAY AGREEMENT BETWEEN ADAMS  
COUNTY AND HILLEN HOLDINGS, LLC FOR PROPERTY NECESSARY FOR THE  
DAHLIA STREET ROADWAY AND DRAINAGE IMPROVEMENTS PROJECT EAST 74<sup>TH</sup>  
AVENUE TO EAST 78<sup>TH</sup> AVENUE

WHEREAS, Adams County is in the process of acquiring right-of-way and easements along Dahlia Street corridor from East 74<sup>th</sup> Avenue to East 78<sup>th</sup> Avenue for the Dahlia Street Roadway and Drainage Improvements Project (the “Project”); and,

WHEREAS, the intention of this Project is to identify and improve the overall roadway and drainage (the “Improvements”); and,

WHEREAS, this right-of-way acquisition is a portion of 7500 Dahlia Street, 7550 Dahlia Street, and 7600 Dahlia Street located in the Northeast Quarter of Section 31, Township 2 South, Range 67 West of the 6<sup>th</sup> Principal Meridian, County of Adams, State of Colorado, and owned by Hillen Holdings, LLC (the “Parcels”); and,

WHEREAS, Adams County requires ownership of the Parcels for construction of the Improvements; and,

WHEREAS, Hillen Holdings, LLC, is willing to sell the Parcels to Adams County under the terms and conditions of the attached Right-of-Way Agreement.

NOW, THEREFORE, BE IT RESOLVED by the Board of County Commissioners, County of Adams, State of Colorado, that the attached Right-of-Way Agreement between Adams County and Hillen Holdings, LLC, a copy of which is attached hereto and incorporated herein by this reference, be and hereby is approved.

BE IT FURTHER RESOLVED that the Chair of the Board of County Commissioners is hereby authorized to execute said Right-of-Way Agreement on behalf of Adams County.

### Right-of-Way Agreement

This Agreement is made and entered into by and between **Hillen Holdings, LLC** whose address is **2303 Fossil Trace Drive, Golden, CO 80401** (“Owner”), and the County of Adams, State of Colorado, a body politic, whose address is 4430 South Adams County Parkway, Brighton, Colorado, 80601 (“County”) for the conveyance by Owner of a temporary construction easement (“Temporary Construction Easement”) over and across certain property located 7500, 7550, and 7600 Dahlia Street, Commerce City, Colorado 80022 hereinafter (the “Property”) and for compensation to Owner to replace the landscaping and existing sign on the Property that will be disturbed (“Disturbed Landscaping”) as part of and for the County’s Dahlia Street Roadway and Drainage Improvements, East 74<sup>th</sup> Avenue to East 78<sup>th</sup> Avenue (the “Project”). The legal description and conveyance documents for the Construction Easement are set forth in Exhibit A, and the construction designs and plans showing the Project and restoration of the Property are attached hereto as Exhibit B, with both exhibits being fully integrated and incorporated herein by this reference.

The County hereby agrees to compensate Owner in the total amount of **TWO HUNDRED EIGHTY-EIGHT THOUSAND EIGHT HUNDRED SIXTEEN DOLLARS (\$288,816.00)** which consists of \$13,810.00 for conveyance of the Temporary Construction Easement and \$273,136.00 in compensation to replace the Disturbed Landscaping and \$1,870.00 for removal of the existing sign. This consideration has been agreed upon and between the parties as the total just compensation due to the Owner and the consideration shall be given and accepted in full satisfaction of this Agreement.

In consideration of the above premises and the promises and covenants below, the Owner and the County agree to the following:

1. The Owner hereby warrants that the Owner is the sole Owner of the Property, that the Owner owns the Property in fee simple subject only to matters of record and that the Owner has the power to enter into this Agreement.

2. The County hereby warrants that it has full authority to enter into this Agreement, and it has full authority to fulfill and enforce all representations and warranties provided herein.
3. The Owner agrees to execute and deliver to the County the attached conveyance documents as soon as possible following the execution of this Agreement and the County agrees to tender payment by check or wired funds for the compensation agreed upon during the month of February, 2021.
4. The Owner hereby irrevocably grants to the County the Temporary Construction Easement on the Property, as described in Exhibit A, and according to the terms and conditions herein, upon execution of this Agreement by the Owner and the County.
5. The County intends to construct the project pursuant to the attached Hillen Plan Sheets. The Parties acknowledge that the Hillen Plan Sheets are subject to modification and the actual construction of the Project might vary from the plan sheets. If the County determines that significant changes or deviations are necessary within the Owner's property, the County will address the impacts of such significant changes or deviations with the Owner and may provide compensation when appropriate. The County represents that the construction of the Project may last up to twelve months. As set forth in Exhibit B, the County may extend the duration of the Temporary Construction Easement in exchange for additional compensation to Owner in the amount of \$1,150.00 for each month that the Project continues beyond twelve months. During construction of the Project, the County or its contractor will provide Hillen with a monthly update of the progress of construction that will include a copy of the current construction schedule.
6. The County through its contractor shall assure that reasonable access shall be maintained to the Owner's property for ingress and egress, at all times during the Project and during the term of the Temporary Construction Easement. If necessary, any full closure of access shall be coordinated between the contractor and

the Owner and/or its agent.

7. The County agrees to replace the existing fencing around the Property with a temporary fence that will ensure the security of Owner's Property at all times during the County's Project and the duration of the Temporary Construction Easement. The County also agrees that all electrical outlets located within or adjacent to the Temporary Construction Easement shall be protected in place during the Project and the duration of the Temporary Construction Easement.
8. The County will remove all existing landscaping located on the parts of Owner's Lots 1, 2, 3, 4, and 5 that are subject to the Temporary Construction Easement, which consists of approximately 23,003 square feet of irrigated landscaping ("Removed Landscaping"). Owner agrees to remove from the Temporary Construction Easement, at his sole cost, all existing decorations, equipment, and other material that he wishes to salvage. Any and all privately owned improvements such as fences, and mailboxes will be replaced by the County.
9. The County's construction plans indicate an existing freestanding sign that is located on the property within the affected area of the temporary construction easement. The County will not reset or reconstruct the sign. But the County has agreed to reimburse the owner the expense to reset or reconstruct the improvements as made part of this agreement. The County has agreed to pay \$1,870 for the relocation and permitting costs. Owner must comply with the County's normal approval process before re-installing the sign.
10. In order to compensate Owner for the costs to replace the Removed Landscaping with new landscaping that will meet the County's landscaping requirements for Lots 1, 2, 3, 4, and 5, the County has agreed to pay to owner the amount of: \$273,136.00. It will be the Owner's responsibility to use these funds to restore the Removed Landscaping.
11. The Owner has entered into this Agreement acknowledging that the County has the power of eminent domain and required the Property for a public purpose.

12. If the Owner fails to convey the Temporary Construction Easement set forth in this Agreement for any reason, except the County's nonpayment of compensation due under this Agreement, the County may at its option, bring an action against the Owner for specific performance regarding conveyance of the Temporary Construction Easement.
13. This Agreement and the documents incorporated herein contains all agreements, understandings and promises between the Owner and the County, relating to the Project and shall be deemed a contract binding upon the Owner and County and extending to the successors, heirs and assigns.
14. The Owner shall be responsible for reporting proceeds of the sale to taxing authorities, including the submittal of Form 1099-S with the Internal Revenue Service, if applicable.
15. Owner or his contractor may restore and replace the Removed Landscaping to a condition conforming to Conditional Use Permit requirements without obtaining a permit or any other approval from the County.
16. This Agreement has been entered into in the State of Colorado and shall be governed according to the laws thereof.

**Owner:**

By: 

William D. Hillen for Hillen Holdings, LLC

Date:

Approved:

BOARD OF COUNTY COMMISSIONERS-COUNTY OF  
ADAMS, STATE OF COLORADO

---

Chair

Date

Approved as to Form:

---

County Attorney



## PUBLIC HEARING AGENDA ITEM

<b>DATE OF PUBLIC HEARING:</b> February 23, 2021
<b>SUBJECT:</b> Approval of CSBG Agreement between Adams County and Access Housing
<b>FROM:</b> Katie Griego, Human Services Director
<b>AGENCY/DEPARTMENT:</b> Human Services
<b>HEARD AT STUDY SESSION ON</b>
<b>AUTHORIZATION TO MOVE FORWARD:</b> <input type="checkbox"/> YES <input type="checkbox"/> NO
<b>RECOMMENDED ACTION:</b> That the Board of County Commissioners Approves of the CSBG Agreement between Adams County and Access Housing

### **BACKGROUND:**

Adams County has received Community Services Block Grant funds to ameliorate the effects of poverty in local communities from the State Department of Local Affairs (DOLA) since 1974. On September 22, 2020, the Community Action Plan and 2021 budget was approved, which included \$306,000 to be allocated to sub-grantees. Community Services Block Grant Advisory Council respectfully recommends funding Access Housing for \$100,000.

The recommendation is to approve the 2020 Agreement with Access Housing.

### **AGENCIES, DEPARTMENTS OR OTHER OFFICES INVOLVED:**

Human Services  
Access Housing

### **ATTACHED DOCUMENTS:**

2021 Access Housing Resolution  
2021 Access Housing Agreement

**FISCAL IMPACT:**

Please check if there is no fiscal impact . If there is fiscal impact, please fully complete the section below.

<b>Fund:</b> 34
<b>Cost Center:</b> 951016.8810

	<b>Object Account</b>	<b>Subledger</b>	<b>Amount</b>
Current Budgeted Revenue:	5335		\$306,000
Additional Revenue not included in Current Budget:	5335		\$0
<b>Total Revenues:</b>			<u>\$306,000</u>

	<b>Object Account</b>	<b>Subledger</b>	<b>Amount</b>
Current Budgeted Operating Expenditure:	8810		\$306,000
Add'l Operating Expenditure not included in Current Budget:	8810		\$0
Current Budgeted Capital Expenditure:			
Add'l Capital Expenditure not included in Current Budget:			
<b>Total Expenditures:</b>			<u>\$306,000</u>

**New FTEs requested:**                     YES             NO

**Future Amendment Needed:**         YES             NO

**Additional Note:**

We are requesting \$100,000 of the CSBG CARES Act funds be allocated to Access Housing.



BOARD OF COUNTY COMMISSIONERS FOR  
ADAMS COUNTY, STATE OF COLORADO

RESOLUTION APPROVING COMMUNITY SERVICES BLOCK GRANT SUBGRANTEE  
AGREEMENT BETWEEN ADAMS COUNTY AND ACCESS HOUSING

Resolution 2021

WHEREAS, the Federal Government has established the Community Services Block Grant Program (“CSBG”) to provide a range of services and activities designed to have an impact on the causes of poverty in local communities; and,

WHEREAS, U.S Department of Health and Human Services allocates Community Services Block Grant funds to the State of Colorado, Department of Local Affairs through an annual formula allocation; and,

WHEREAS, the CSBG Community Action Plan and 2021 budget was approved by the Adams County Board of County Commissioners on September 22, 2020, which included \$306,000 to be allocated to sub-grantees annually; and,

WHEREAS, the Community Services Block Grant Advisory Council recommends Access Housing to receive \$100,000; and,

WHEREAS, the project award will continue to be included as part of the 2021-2023 Adams County Community Action Plan to the State of Colorado, Department of Local Affairs.

NOW THEREFORE, BE IT RESOLVED, by the Board of County Commissioners, County of Adams, State of Colorado, that Community Services Block Grant Subgrantee Agreement between Adams County and Access Housing, a copy of which is attached hereto and incorporated herein by reference, be and hereby is approved.

BE IT FURTHER RESOLVED, that the Chair of the Board of County Commissioners is hereby authorized to execute said Subgrantee Agreement and any attending documents on behalf of Adams County.

**COMMUNITY SERVICES BLOCK GRANT  
2021 – 2023 AGREEMENT**

For Performance of a Community Services Block Grant Activity  
Catalog of Federal Domestic Assistance (CFDA) Number: 93.569

**ARTICLE I: GENERAL PROVISIONS**

**PARTIES TO THIS AGREEMENT:** This Agreement, dated for reference purposes only this 1<sup>st</sup> day of January, 2021, by and between Adams County, a body politic and corporate, known hereafter as “COUNTY”, and Access Housing, located at 6978 Colorado Blvd. Commerce City, CO 80022, known hereafter as the GRANTEE”.

**WHEREAS**, the COUNTY requires the provision of certain services and products in connection with the program funded by grants from the Community Services Block Grant (CSBG) and which must conform to one or more of the following objectives (“Program”):

- A. To provide a range of services and activities having a measurable and potentially major impact on causes of poverty in the community or those areas of the community where poverty is a particularly acute problem.
- B. To provide activities designed to assist low-income participants;
  - (i) to secure and retain meaningful employment;
  - (ii) to attain an adequate education and cognitive development;
  - (iii) to make better use of available income and/or asset building;
  - (iv) to obtain and maintain adequate housing and a suitable living environment;
  - (v) to obtain emergency assistance to meet immediate and urgent individual and family needs, including the need for health and social/behavioral development services, nutritious food, housing, and employment-related assistance;
  - (vi) to remove obstacles and solve problems which block the achievement of self-sufficiency;
  - (vii) to achieve greater participation in the affairs of the community through civic engagement and community involvement; and
  - (viii) to make effective use of other related programs such as agency capacity building.
- C. To provide on an emergency basis for the provision of such supplies and services, nutritious food and related services, as may be necessary to counteract conditions of starvation and malnutrition among the poor;
- D. To coordinate and establish linkages between governmental and other social services programs to assure the effective delivery of such services to low-income individuals;
- E. To encourage the use of entities in the private sector of the community in efforts to ameliorate poverty in the community.

**WHEREAS**, the Community Services Block Grant Advisory Council (CSBGAC) has recommended that the services and products provided for herein be included in the COUNTY’s Application and Community Action Plan to the State for CSBG funds (“Project Plan”); and

**WHEREAS**, the GRANTEE is qualified to provide the services and products as identified in this Agreement.

**NOW, THEREFORE**, in consideration of the mutual promises, payments and other provisions hereof, the parties agree as follows:

## **ARTICLE II: SCOPE OF SERVICES**

Section 1. The COUNTY hereby agrees to engage the GRANTEE, and the GRANTEE agrees to provide the following services and products as described in the attached Exhibit 1 Scope of Services (“Services”). The Services shall be provided to individuals and families at or below 125% of “poverty income” as defined annually by the United States Department of Health & Human Services only to Adams County residents. Income eligibility and address verification information must be collected and kept in each CSBG customer file.

Section 2. The GRANTEE covenants that it has, or will obtain at its own expense, all personnel, goods, services and equipment required to perform the Services and shall use no funds provided hereunder for any expense other than those expenses required to perform the Services and that are outlined in this agreement.

Section 3. All Services provided hereunder shall be performed by the GRANTEE. No personnel engaged in the performance of those Services shall be employees of the COUNTY, nor shall any personnel providing those Services have any contractual relationship with the COUNTY.

Section 4. The COUNTY reserves the right to enter into other contracts related to the Services, and the GRANTEE agrees to cooperate with the COUNTY and its other contractors with respect to the coordination of those Services.

## **ARTICLE III: DURATION OF CONTRACT**

Section 1. Services provided hereunder shall commence on: January 1, 2021 and shall continue through December 31, 2021, (the “Period of Performance”). The agreement shall be automatically renewed up until July 30, 2024 providing satisfactory service is given and all terms and conditions of this Agreement have been fulfilled. Such extensions must be mutually agreed upon and is contingent upon federal funding from the United States Department of Health & Human Services through the Colorado Department of Local Affairs, known hereafter as “DOLA”.

Section 2. If the GRANTEE fails to comply with any contractual provision, the COUNTY, may, after notice to the GRANTEE, suspend the Agreement and withhold further payment or prohibit the GRANTEE from incurring additional obligation of contractual funds, pending corrective action by the GRANTEE or a decision by the COUNTY to terminate in accordance with this Agreement. The COUNTY may determine to allow such necessary and proper costs which the GRANTEE could not reasonably avoid during the period of suspension.

Section 3. If, through any cause, either party shall fail to honor or otherwise fulfill any of the promises, covenants, obligations, agreements or stipulations of this Agreement, the other party shall have the right to terminate this Agreement by giving ten (10) days written notice to the other party of such termination, specifying the reasons for such termination and the effective date thereof. In the event the GRANTEE is terminated under this section, the GRANTEE shall not be relieved of liability to the COUNTY or the State for any damages sustained by the COUNTY or the State by virtue of any breach of this Agreement by the GRANTEE, and the COUNTY or the State may withhold any payment to the GRANTEE for the purpose of settlement until such time as the exact damage due the COUNTY from the GRANTEE is determined.

Section 4. In addition to other specified remedial actions, the State or COUNTY may exercise the following remedial actions should it find that the GRANTEE substantially failed to satisfy or perform the duties and obligations in this Agreement. Substantial failure to satisfy the duties and obligations shall be defined to mean insufficient, incorrect, improper activities or inaction by the GRANTEE. These remedial actions are as follows:

- 1) Withhold payment to the GRANTEE until the necessary services or corrections in performance are

satisfactorily completed;

- 2) Request the removal from work on the Agreement of employees of the GRANTEE whom the COUNTY or the State justifies as being incompetent, careless, insubordinate, unsuitable, or otherwise unacceptable, or whose continued employment on the Agreement it deems to be contrary to the public interest or not in the best interest of the COUNTY or the State;
- 3) Deny payment for those services or obligations which have not been performed and which due to circumstances caused by the GRANTEE cannot be performed or if performed would be of no value to the COUNTY or the State. Denial of the amount of payment must be reasonably related to the amount of work or performance lost to the COUNTY or the State;

or

- 4) Terminate the Agreement for cause.

Section 5. The parties hereto may terminate this Agreement by mutual consent by setting forth in writing the terms, conditions and effective date of such termination, in which case the GRANTEE shall be reimbursed an amount equal to actual eligible expenses incurred as of the date of termination.

Section 6. If the State terminates the COUNTY's Contract with the State as identified in Article V, Section 8, whether for the convenience of the State or for cause, this Agreement shall immediately terminate. If such termination is for cause due to GRANTEE's failure of performance, the provisions of Article III, Section 3, 4, 7, and 8 shall apply and the GRANTEE shall not be relieved of liability to the COUNTY for any damages sustained by the COUNTY by virtue of any breach of the Contract by the GRANTEE, and the COUNTY may withhold any payment to the GRANTEE for the purpose of settlement until such time as the exact damage due the COUNTY from the GRANTEE is determined. If such termination is for the convenience of the State, the GRANTEE shall be reimbursed in an amount equal to actual expenses incurred as of the date of termination.

Section 7. The COUNTY without cause may terminate this Agreement at any time if written notice to terminate is provided to the GRANTEE more than ten (10) days prior to the effective date of the termination. In such event, the GRANTEE shall be paid for all eligible work satisfactorily completed commensurate with the amount of work done on the Scope of Services up to the date of termination less all amounts previously paid, and in addition thereto, any other amount as mutually agreed upon by the parties for the documented direct and incidental termination expenses due to the termination.

Section 8. Should the COUNTY terminate this Agreement for cause, as provided in Section 3 above, no further payments shall be due to the GRANTEE, including payment for Services provided prior to the effective date of termination.

Section 9. Nothing herein shall preclude either party from pursuing such remedies at law or at equity as may be appropriate.

Section 10. If this Agreement is terminated for cause, all finished or unfinished documents, data, studies, surveys, drawings, maps, models, photographs, and reports or other material prepared by the GRANTEE under this Agreement shall, at the option of the COUNTY, become the COUNTY's property, and the GRANTEE shall be entitled to receive just and equitable compensation for any satisfactory work completed on such documents and other materials.

#### **ARTICLE IV: COMPENSATION AND PROJECT BUDGET**

Section 1. The COUNTY shall reimburse the GRANTEE for the actual cost of Services provided hereunder, however, such reimbursement shall not exceed One Hundred Thousand Dollars and 00/100 (\$100,000) over the Period of Performance/per year.

- A. Funds under this Agreement shall be spent as set forth in the "Project Budget" attached hereto as Exhibit 2 and incorporated herein by reference.
- B. The GRANTEE shall adhere to the Project Budget as set forth more specifically in subparagraph (A) above to the fullest practicable extent, but the GRANTEE is not precluded from making minor changes within the Scope of Services and Project Budget as necessary, when preapproved by the COUNTY.

Section 2. The COUNTY shall invoice DOLA for payments due and may make payment to the GRANTEE before the receipt of such DOLA CSBG funds for the purpose of the continuation of Services provided in accordance with the State CSBG Plan, the State of Colorado Local Government Financial Management Manual and this Agreement.

Section 3. The parties hereto recognize that compensation paid to the GRANTEE hereunder is funded from CSBG. If funding is not secured under CSBG, or if compensation to the GRANTEE is disapproved thereunder, then this Agreement shall be null and void and no payment will be due the GRANTEE from the COUNTY. Furthermore, if, for any reason, reimbursements from CSBG CARES Act to the COUNTY are delayed, payments to the GRANTEE by the COUNTY may be delayed for the same length of time.

Section 4. GRANTEE acknowledges and is hereby given notice that the financial obligations of the COUNTY under this Agreement, payable after the current fiscal year, are contingent upon funds for this Agreement being appropriated, budgeted and otherwise made available for each fiscal year thereafter. In the event it is determined that funds will not be budgeted and appropriated, the COUNTY may terminate this Agreement by giving GRANTEE notice of such non-appropriation. The COUNTY's fiscal year commences January 1 and ends December 31.

Section 5. If the COUNTY makes any payments for all or any portion of the Services done by the GRANTEE prior to the COUNTY receiving payment from the State and the COUNTY is notified by the State that the State will not reimburse the COUNTY for the services provided by the GRANTEE, the GRANTEE agrees to repay the COUNTY within thirty (30) days of receipt of notice from the COUNTY that the funds must be repaid to the COUNTY.

#### **ARTICLE V: ASSURANCES**

Section 1. The GRANTEE will not discriminate against any employee or applicant for employment, or against any applicant for services or benefits because of race, color, religion, sex or national origin except to the extent that the religious organization exemption provided under 702 of the Civil Rights Act of 1964 (42 U.S.C. 2000e-1) applies. The GRANTEE shall adhere to acceptable affirmative action guidelines in selecting employees, and shall ensure that employees are treated equally during employment without regard to race, religion, sex or national origin. Such action shall include, but is not limited to the following: employment, upgrading, demotion or transfer, recruitment or recruitment advertising, layoff or termination, rates of pay and other compensation and selection for training, including apprenticeship. Furthermore, the GRANTEE will not discriminate on the grounds of race, color, sex or national origin in the selection and retention of its own grantees or contractors, including suppliers of materials and lessors of equipment. Any prohibition against discrimination on the basis of age under the Age Discrimination Act of 1975 or with regard to otherwise qualified disabled individuals as provided in Section 504 of the Rehabilitation Act of 1973 or the Americans with Disabilities Act shall also apply to the Services provided herein. The GRANTEE agrees to take positive

steps to comply and advance in employment qualified disabled persons and to comply with applicable U.S. Department of Health and Human Services Regulations (45 CFR Part 84). GRANTEE agrees to indemnify and hold harmless the COUNTY and the State of Colorado from any claims or demands which may arise under this provision.

Section 2. The GRANTEE shall not compel any employee or volunteer in performing the work of this Agreement to work in surroundings or under working conditions which are unsanitary or dangerous or hazardous to his or her health or safety.

Section 3. The GRANTEE shall comply with Executive Order No. 11426 entitled "Equal Employment Opportunity" as supplemented in the Department of Labor Regulations (41 CFR Section 84) and to execute such provisions as may be required.

Section 4. Independent Contractor/GRANTEE and Indemnification.

- A. In performing the Work, the GRANTEE acts as an independent contractor responsible for calculating, withholding, and paying all Federal and State taxes and for obtaining necessary and adequate Workers Compensation Insurance, general liability insurance and any other insurance required under this Agreement. GRANTEE employees are not and shall not become employees, agents or servants of the COUNTY hereunder. The GRANTEE and GRANTEE employees are not entitled to unemployment insurance benefits unless unemployment compensation coverage is provided by the GRANTEE or some other entity and the GRANTEE is obligated to pay Federal and State income tax on any monies paid pursuant to this Agreement.
- B. The GRANTEE shall indemnify, save and hold harmless the State and the COUNTY, and their employees, officials, board members, officers and agents, against any and all claims, losses, injuries, damages, expenses, liability and court awards including costs, expenses, and attorney fees incurred as a result of any act or omission by the GRANTEE, or its employees, agents, subcontractors, or assignees pursuant to the terms of this Agreement. This indemnification provision shall survive completion of the services and termination of this Agreement. Nothing herein shall be construed as a waiver of defenses available to the COUNTY under the Governmental Immunity Act.

Section 5. The GRANTEE shall comply with all applicable State and Federal laws, rules, regulations and Executive Orders of the Governor of Colorado, involving non-discrimination on the basis of race, color, religion, national origin, age, handicap, or sex. GRANTEE may utilize the expertise of the State Minority Business Office within the Office of the Governor, for assistance in complying with the non-discrimination and affirmative action requirements of this Agreement and applicable statutes.

Section 6. The GRANTEE shall not utilize any funds provided through this Program for political activities.

Section 7. The GRANTEE shall not utilize any funds provided through this Program to provide voters and prospective voters with transportation to the polls or provide similar assistance in connection with an election or any voter registration activity.

Section 8. The GRANTEE shall comply with all applicable State and Federal laws, rules, circulars, guidelines, regulations and requirements and all obligations imposed on the COUNTY or its subcontractors in the COUNTY's Contract with the State of Colorado, Department of Local Affairs for the CSBG program; the Special Provisions attached and incorporated therein; the Federal Terms and Conditions and Assurance in Appendices thereto; and any special conditions incorporated into or attached to a grant award letter which covers funds paid to the GRANTEE. The terms and conditions of that Contract and the Special Provisions are applicable to this Agreement and are made a part hereof and incorporated herein by reference, whether or not attached

hereto. The GRANTEE agrees that it shall cooperate with the COUNTY in the compliance by the COUNTY of all the requirements set forth in the Certifications attached hereto as Exhibit 4 and incorporated herein by reference. The GRANTEE by execution of this Agreement hereby makes the applicable assurances and certifications set forth in the Certifications attached hereto as Exhibit 4.

Section 9. The GRANTEE covenants that it presently has no interest and shall not acquire any interest, direct or indirect, which would conflict in any manner or degree with the performance of Services required to be performed under this Agreement. The GRANTEE further covenants that in the performance of this Agreement no person having any such interest will be employed.

Section 10. The GRANTEE assures that it shall comply with Public Law 101-121, Section 319, 29 CFR Part 93, restrictions on lobbying.

Section 11. The GRANTEE shall ensure compliance with the Drug-Free Workplace Requirements for Federal Grant Recipients under Sections 5153-5158 of the Anti-Drug Abuse Act of 1988 (41 U.S.C. 702-707).

Section 12. The GRANTEE will ensure compliance with Public Law 103.227, Part C-Environmental Tobacco Smoke, also known as the Pro-Children Act of 1994 (Act). This Act requires that smoking may not be permitted in any portion of any indoor facility owned or leased or contracted by an entity and used routinely or regularly for the provision of health, day care, education or library services to children under the age of 18, if the services are funded by Federal programs either directly or through State or local governments. The above requirement will be included in any subawards which contain provisions for children's services and that all subcontractors shall certify compliance accordingly.

Section 13. The GRANTEE shall indemnify, save and hold harmless the State and the COUNTY, and their employees and agents, against any and all claims, damages, liability and court awards including costs, expenses, and attorney fees incurred as a result of any act or omission by the GRANTEE, or its employees, agents, subcontractors, or assignees pursuant to the terms of this Agreement. This indemnification provision shall survive completion of the services termination of this Agreement. Nothing herein shall be construed as a waiver of defenses available to the COUNTY under the Governmental Immunity Act.

#### **ARTICLE VI: CONTINGENT FUNDING**

The parties hereto agree that should the State of Colorado or the Federal government disapprove this Agreement or refuse or fail to make the grant to the COUNTY as contemplated by this Agreement, then this Agreement shall be void and shall not be binding on any party to it. Unearned payments hereunder may be suspended or terminated in the event the GRANTEE refuses to accept additional terms or conditions to this Agreement that may be imposed by the Federal government, the COUNTY, or the State of Colorado after the effective date hereof.

#### **ARTICLE VII: RECORDS, REPORTS, AUDITS AND INSPECTIONS**

Section 1. The GRANTEE shall permit the COUNTY, and State and Federal representatives, to inspect, examine, copy or mechanically reproduce, on or off premises, as deemed necessary for grant purposes, all records pertaining to this Agreement for its term and for a period of five (5) years after its final payment hereunder or for such further period as may be necessary to resolve any matters which may be pending.

Section 2. The GRANTEE is subject to all procurement, fiscal and Program requirements to which the COUNTY is subject under the CSBG grant, including pertinent Federal and State guidelines including OMB Uniform Guidance (2CFR 200) requirements for Non Profit Organizations.

Section 3. The GRANTEE will follow the COUNTY's rules and procedures for reporting expenditures, travel, per diem expenses, purchases and bid procedures.

Section 4. During the Agreement term, the retention period set forth in Section 1 above, and as long thereafter as records are maintained, at any time during normal business hours, the authorized representatives of the COUNTY, the State of Colorado, and Comptroller General of the United States shall have the right of access to any books, documents, papers or other records of the GRANTEE with respect to all matters covered by this Agreement in order to make audits, investigations, inspections, examinations, excerpts, and transcripts.

Section 5. For work performed under this Agreement the GRANTEE shall cause an audit to be conducted and submitted to the COUNTY in accordance with the applicable requirements in the OMB Super Circular. If an audit is not required in accordance with OMB Super Circular, the GRANTEE shall provide a year-end financial statement for each fiscal year in which the GRANTEE has received funding for this project.

The audits or financial statement shall be furnished to the COUNTY within six (6) months after the end of the GRANTEE's fiscal year.

Section 6. The GRANTEE shall provide to the COUNTY a CSBG Semiannual Performance Report summarizing the Services which includes activities, progress, outcomes, and number of clients served (report format will be provided). The GRANTEE shall provide the COUNTY an Annual Report (report format to be provided) summarizing the Services which include activities, progress, outcomes, and number of clients served by **January 31st of each year**. The GRANTEE shall provide the COUNTY a monthly payment request on the 10<sup>th</sup> of each month. GRANTEE shall meet all other reporting requirements in accordance with the State CSBG Plan and the Local Government Financial Management Manual and any other reporting requirements required by the COUNTY, Federal government or the Colorado Department of Local Affairs. The submission of reports in a timely manner shall be the responsibility of the GRANTEE and failure to comply may result in a delay of payment of funds or termination of this Agreement.

Section 7. The GRANTEE shall follow all State of Colorado Local Government Financial Management Manual financial rules and procedures including, but not limited to, procedures for accounting, reporting, expenditures, and budgeting. Minimum standards to be adhered to are those contained in the Local Government Financial Management Manual.

Section 8. In the event the GRANTEE shall obtain access to any records or files of the State or COUNTY in connection with, or during the performance of, this contract, the GRANTEE shall keep such records and information confidential and shall comply with all laws and regulations concerning the confidentiality of such records to the same extent as such laws and regulations apply to the State or the COUNTY. The GRANTEE agrees to notify and advise in writing all employees, agents, consultants, licensees, or sub-contractors of the said requirements of confidentiality and of possible penalties and fines imposed for violation thereof, and secure from each an acknowledgment of such advisement and agreement to be bound by the terms of this agreement as an employee, agent, consultant, licensee, or sub-contractor of the GRANTEE, as the case may be. Any breach of confidentiality by the GRANTEE or third-party agents of the GRANTEE shall constitute good cause for the COUNTY or the State to cancel this contract without liability; any and all information delivered to the GRANTEE shall be returned to the COUNTY. Any COUNTY or State waiver of an alleged breach of confidentiality by the GRANTEE or third-party agent of the GRANTEE is not to imply a waiver of any subsequent breach.

Section 9. All costs charged to the contract must be documented. For example, the GRANTEE must maintain signed time and attendance records for each and every individual employee and payroll documents approved by an official of the organization. Individual time distribution records must be maintained for allocating an employee's salary between this contract and other funding sources. Source documentation must be maintained for other costs such as receipts, travel vouchers, invoices, bills, or affidavits. Volunteer costs must be documented. All in-kind and other matching contributions, including grant award documents and receipts from other funding sources must be documented.



**ARTICLE VIII: AMENDMENTS**

Section 1. This Agreement contains the entire understanding between the parties. Either party to this Agreement may request Amendments to this Agreement at any time, but no change shall be binding unless it is mutually agreed upon by the parties to this Agreement. All Amendments shall be in writing, authorized and executed prior to any work being done thereon and will be contingent upon Adams County approval.

Section 2. Any change in or new Federal, State or local law, rule, Executive Order, Office of Management & Budget Circular, or other regulation under which the Services are to be performed which may constitutionally be applied to the Services and which, by its terms, is intended to be applied to the Services, shall be deemed to be incorporated into this Agreement.

**ARTICLE IX: APPLICABLE LAWS**

Section 1. The parties hereto agree that this Agreement shall be governed by and construed according to the laws of the State of Colorado.

Section 2. The courts of the State of Colorado shall have sole and exclusive jurisdiction of any disputes or litigation arising hereunder. Venue for any and all legal actions arising hereunder shall lie in the District Court in and for Adams County, State of Colorado.

Section 3. The GRANTEE specifically agrees to comply in the performance hereof with all local, State and Federal ordinances, codes, laws, rules, regulations, orders, and guidelines that are referenced herein and applicable to the Services or that may be or become applicable to the Services even though not stated herein, as described in the attached Exhibit 3 ("Certifications").

**ARTICLE X: NON-ASSIGNMENT**

The GRANTEE represents, covenants and warrants that it will not assign its rights nor delegate its obligations hereunder and breach of this provision shall void the obligations of the COUNTY hereunder as of the date of breach and this Agreement shall be void as of said date.

**ARTICLE XI: SUCCESSORS**

The GRANTEE covenants that the provisions of this Agreement shall be binding upon its successors and agents.

**ARTICLE XII: REPRESENTATIVES**

All applicable invoices, statements, notices, inquiries, and replies shall be addressed and served upon the respective representatives at the addresses below. The following individuals are designated for the purposes of this Agreement as representatives of the COUNTY and the GRANTEE (or their successors or assigns), respectively:

Adams County Attorney's Office 4430 S. Adams County Parkway Brighton, Colorado 80601 Phone: 720-523-6116 Fax: 720-523-6114
Adams County Human Services Contact: Carol Johnson, Specialty Programs Administrator Address: 11860 Pecos St. Westminster, CO 80234 Phone: 720-523-2154

E-mail: <a href="mailto:cajohnson@adcogov.org">cajohnson@adcogov.org</a>
GRANTEE NAME: Access Housing Contact: Chris Boyd Address: 6978 Colorado Blvd. Commerce City, CO 80022 Phone: 303-289-7078 E-mail: <a href="mailto:chris.boyd@acchouse.org">chris.boyd@acchouse.org</a>

The parties may change their representatives at any time by written notice to the other party.

**ARTICLE XIII: ILLEGAL ALIENS**

Section 1. COMPLIANCE WITH C.R.S. § 8-17.5-101, ET. SEQ. AS AMENDED 5/13/08: Pursuant to Colorado Revised Statute (C.R.S.), § 8-17.5-101, *et. seq.*, as amended 5/13/08, the Contractor shall meet the following requirements prior to signing this Agreement (public contract for service) and for the duration thereof:

- 1.1. The Contractor shall certify participation in the E-Verify Program (the electronic employment verification program that is authorized in 8 U.S.C. § 1324a and jointly administered by the United States Department of Homeland Security and the Social Security Administration, or its successor program) or the Department Program (the employment verification program established by the Colorado Department of Labor and Employment pursuant to C.R.S. § 8-17.5-102(5)) on the attached certification.
- 1.2. The Contractor shall not knowingly employ or contract with an illegal alien to perform work under this public contract for services.
- 1.3. The Contractor shall not enter into a contract with a subcontractor that fails to certify to the Contractor that the subcontractor shall not knowingly employ or contract with an illegal alien to perform work under this public contract for services.
- 1.4. At the time of signing this public contract for services, the Contractor has confirmed the employment eligibility of all employees who are newly hired for employment to perform work under this public contract for services through participation in either the E-Verify Program or the Department Program.
- 1.5. The Contractor shall not use either the E-Verify Program or the Department Program procedures to undertake pre-employment screening of job applicants while this public contract for services is being performed.
- 1.6. If Contractor obtains actual knowledge that a subcontractor performing work under this public contract for services knowingly employs or contracts with an illegal alien, the Contractor shall: notify the subcontractor and the County within three days that the Contractor has actual knowledge that the subcontractor is employing or contracting with an illegal alien; and terminate the subcontract with the subcontractor if within three days of receiving the notice required pursuant to the previous paragraph, the subcontractor does not stop employing or contracting with the illegal alien; except that the contractor shall not terminate the contract with the subcontractor if during such three days the subcontractor provides information to establish that the subcontractor has not knowingly employed or contracted with an illegal alien.
- 1.7. Contractor shall comply with any reasonable requests by the Department of Labor and Employment (the Department) made in the course of an investigation that the Department is undertaking pursuant to the authority established in C.R.S. § 8-17.5-102(5).

- 1.8. If Contractor violates this Section of this Agreement, the County may terminate this Agreement for breach of contract. If the Agreement is so terminated, the Contractor shall be liable for actual and consequential damages to the County.

Section 2. GRANTEE must confirm that any individual resides in Adams County, when such individual applies for public benefits provided under this Agreement.

#### **ARTICLE XIV: OFFICIALS NOT TO BENEFIT**

Section 1. No member of the COUNTY government, Commissioners or individual officers elected therein, shall be admitted to any share or part of this Agreement or any benefit that may arise there from.

Section 2. Nothing in this Agreement is intended to create rights in any third-party beneficiary.

#### **ARTICLE XV: SEVERABILITY**

The declaration by any court or other binding legal authority that any provision of this Agreement is illegal and void shall not affect the legality and enforceability of any other provision of this Agreement unless said provisions are mutually dependent.

#### **ARTICLE XVI: ADVERTISEMENT AND PUBLIC NOTICES**

GRANTEE shall ensure that any radio or television announcements, newspaper advertisements, press releases, pamphlets, mail campaigns, or any other method advising the public of their program that is funded with CSBG funds includes the following statement when feasible: "The funding source for this activity is Community Service Block Grant Funds made available through the Human Services Department of Adams County, Colorado."

**CONTRACTOR'S CERTIFICATION OF COMPLIANCE**

Pursuant to Colorado Revised Statute, § 8-17.5-101, *et seq.*, as amended 5/13/08, as a prerequisite to entering into a contract for services with Adams County, Colorado, the undersigned Contractor hereby certifies that at the time of this certification, Contractor does not knowingly employ or contract with an illegal alien who will perform work under the attached contract for services and that the Contractor will participate in the E-Verify Program or Department program, as those terms are defined in C.R.S. § 8-17.5-101, *et seq.* in order to confirm the employment eligibility of all employees who are newly hired for employment to perform work under the attached contract for services.

CONTRACTOR:

\_\_\_\_\_  
Company Name

\_\_\_\_\_  
Date

\_\_\_\_\_  
Name (Print or Type)

\_\_\_\_\_  
Signature

\_\_\_\_\_  
Title

Note: Registration for the E-Verify Program can be completed at: <https://www.vis-dhs.com/employerregistration>. It is recommended that employers review the sample "memorandum of understanding" available at the website prior to registering

**IN WITNESS WHEREOF**, the parties have caused this Agreement to be duly executed on the day, month and year above written.

**GRANTEE:**

By: \_\_\_\_\_  
Title: \_\_\_\_\_  
Date \_\_\_\_\_

WITNESS my hand and official seal.  
My commission expires: \_\_\_\_\_

\_\_\_\_\_  
Notary Public

STATE OF COLORADO                    )  
  ) ss.  
ADAMS COUNTY                         )

The foregoing Agreement was executed before me this \_\_\_\_\_ day of \_\_\_\_\_, 2021, by \_\_\_\_\_ as the \_\_\_\_\_ of \_\_\_\_\_, the agency named herein, the GRANTEE herein named.

WITNESS my hand and official seal.  
My commission expires: \_\_\_\_\_

\_\_\_\_\_  
Notary Public

**ADAMS COUNTY  
STATE OF COLORADO**

By \_\_\_\_\_  
Chair

Date \_\_\_\_\_

APPROVED AS TO FORM:

\_\_\_\_\_  
Adams County Attorney's Office

**EXHIBIT 1**

**SCOPE OF SERVICES  
COMMUNITY SERVICES BLOCK GRANT**

**Services: *Description of Project***

ACCESS Housing will provide rental assistance via the Homeless Prevention Program through case management, advocacy, resource referral and post intervention follow up.

**Number of Adams County Residents to be served by CSBG Specific Project per year (at or below 125% of poverty): 55**

**EXHIBIT 2**

Budget Line Items – Activity Costs	Amount of County Funds Requested
Operating Supplies	\$5,000
Direct Assistance-Rental/Utility Assistance	\$85,000
Salary: Homeless Prevention Specialist	\$5,000
Salary: Program Innovator	\$5,000
<b>TOTAL EXPENSE BUDGET</b>	<b>\$100,000</b>

**The following back up and source documentation is required to be submitted with monthly payment requests for each eligible expense (additional documentation may be requested to support expenses):**

<b>Eligible expenses:</b>	<b>Required back up and source documentation:</b>
Operating Supplies	Invoices of supplies by percentage of CSBG cost
Direct Assistance	Invoices, copy of checks
Salary and Benefits:	Copies of signed time allocation sheets and full and complete payroll report, including fringe information clearly demonstrating percentages charged each month.

### EXHIBIT 3

#### CSBG CERTIFICATIONS

**The grantee assures that activities implemented with CSBG funds will be:**

- used to accomplish the State CSBG Goals and Objectives stated in the State Plan; and
- within the requirements set forth in the Community Services Block Grant Act, Title IV of the Civil Rights Act, the Age Discrimination Act of 1975, the Rehabilitation Act of 1973, Public Law 103-227, Part C, Environmental Tobacco Smoke, also known as the Pro-Children Act of 1994 (Act), Certification Regarding Drug-Free Workplace Requirements, Certification Regarding Lobbying, Certification Regarding Debarment, Suspension, and Other Responsibility Matters - Primary Covered Transactions, Office of Management and Budget (OMB Circular A110 and A122), and the current State of Colorado CSBG Plan.

**The Grantee also assures that it will:**

- specifically consider, in a public meeting the designation of any local public or private entity to carry out the county community service activities under contract with the county, any local community action agency (CAA) which received federal fiscal 1981-82 funding; and
- consider, on the same basis as other non-governmental organizations, religious organizations to provide the CSBG services, so long as the program is implemented in a manner consistent with the Establishment Clause of the first amendment to the Constitution. Grantees shall not discriminate against an organization that provides assistance under, or applies to provide assistance, on the basis that the organization has a religious character. (Please review Sec.679 Operational Rule in the CSBG Act); and
- provide for coordination between community anti-poverty programs and ensure, where appropriate, that emergency energy crisis intervention programs under Title XXVI (relating to low-income home energy assistance) are conducted in such community; and
- provide, on an emergency basis, for the provision of such supplies and services, nutritious foods, and related services, as may be necessary to counteract conditions of starvation and malnutrition among low-income individuals; and
- coordinate, to the extent possible, programs with and form partnerships with other organizations serving low-income residents of the community and members of groups served, including religious organizations, charitable groups, and community organizations; and
- prohibit the purchase or improvement of land, or the purchase, construction, or permanent improvement (other than low-cost residential weatherization or other energy-related home repairs) of any building or facility with CSBG funds; and
- prohibit, including subcontractors, (a) any partisan or nonpartisan political activity or any political activity associated with a candidate, or contending faction or group, in an election for public or party office, (b) any activity to provide voters or prospective voters with transportation to the polls or similar assistance in connection with any such election, or (c) any voter registration activity; and
- prohibit that persons shall, on the basis of race, color, national origin or sex, be excluded from participation in, be denied the benefits of, or be subjected to discrimination under, any program or activity funded in whole or in part with CSBG. Any prohibition against discrimination on the basis of age under the Age Discrimination Act of 1975 (42 U.S.C 6101 et seq.) or with respect to an otherwise qualified individual with a disability as provided in Section 504 of the Rehabilitation Act of 1973 (29 U.S.C. 12131 et seq.) shall also apply to any such program or activity; and
- participate in the Results-Oriented Management and Accountability (ROMA) System, and describe outcome measure to be used to measure performance in promoting self-sufficiency, family stability, and/or community revitalization; and
- make available for public inspection each plan prepared as part of the program planning process. The Grantee may, at its initiative, revise any plan prepared for CSBG funding and shall furnish the revised plan to the Director of the Community Services Block Grant under the Department of Local Affairs. Each plan prepared for submission shall be made available for public inspection within the county and/or service area in such a manner as will facilitate review of, and comments on, the plan; and
- cooperate with the State and/or County, to determine whether grantee performance goals,



administrative standards, financial management requirements, and other requirements of the State and County, in conducting monitoring reviews including (1) a full on-site review on an annual basis, (2) follow-up reviews if grantee fails to meet the goals, standards, and requirement established by the State, and (3) other reviews as appropriate, including reviews of grantee with other programs that have had other federal, State, or local grants terminated for cause; and

- make available appropriate books, documents, papers, and records for inspection, examination, copying, or mechanical reproduction on or off the premises upon reasonable request by the U.S. Controller General, the State, or their authorized representatives should an investigation of the uses of CSBG funds be undertaken; and
- in the case of county governments or grantees which receive a CSBG award in excess of \$100,000, comply with the following three certifications related to the "Limitation on use of appropriated funds to influence certain Federal Contracting and financial transactions (P.L. 101-121, Section 319 and USC Title 31 Section 1352)":
  1. No Federal appropriated funds have been paid or will be paid by or on behalf of the undersigned, to any person for influencing or attempting to influence an officer or employee of any agency, a Member of Congress, an officer or employee of Congress, or an employee of a Member of Congress in connection with the awarding of any Federal contract, continuation, renewal, amendment, or modification of any Federal contract, grant, loan, or cooperative agreement.
  2. If any funds other than Federal appropriated funds have been paid or will be paid to any person for influencing or attempting to influence an officer or employee of any agency, a Member of Congress, an officer or employee of Congress, or any employee of a Member of Congress in connection with this Federal contract, grant, loan, or cooperative agreement, the undersigned shall complete and submit Standard Form LLL, "Disclosure Form to Report Lobbying," in accordance with its instruction.
  3. The undersigned shall require that the language of this certification be included in the award document for subawards at all tiers (including subcontracts, subgrants, and contracts under grants, loans, and cooperative agreements) and that all subrecipients shall certify and disclose accordingly.

**The Grantee certifies to the best of its knowledge and belief, that it and its principals:**

- a) are not presently debarred, suspended, proposed for debarment, declared ineligible, or voluntarily excluded from covered transactions by any Federal department or agency;
- b) have not within a three-year period preceding this proposal been convicted or had a civil judgment rendered against them for commission of fraud or a criminal offense in connection with obtaining, attempting to obtain, or performing a public transaction; violation of Federal or State antitrust statutes or commission of embezzlement, theft, forgery, bribery, falsification or destruction of records, making false statements, or receiving stolen property;
- c) are not presently indicted for otherwise criminally or civilly charged by a governmental entity (Federal, State or local) with commission of any of the offenses enumerated in paragraph (b) of this certification; and
- d) have not within a three-year period preceding this application had one or more public transactions (Federal, State or local) terminated for cause or default.

**The Grantee further certifies that it:**

- a) requires that smoking not be permitted in any portion of any indoor routinely owned or leased or contracted for by an entity and used routinely or regularly for provisions of health, day care, education, or library services to children under the age of 18, if the services are funded by Federal programs either directly or through State or local governments, by Federal grant, contract, loan, or loan guarantee.
- b) that it will require the language of this certification be included in any sub awards which contain provisions for the children's services and that all Subgrantees shall certify accordingly.

*If you are unable to certify to any of the statements in this certification, please attach an explanation to this application.*

SIGNATURE: \_\_\_\_\_

PRINT NAME: \_\_\_\_\_

POSITION TITLE: \_\_\_\_\_

DATE: \_\_\_\_\_

**EXHIBIT 4**

**INSURANCE**

**General Liability Insurance:** Commercial General Liability Insurance written on ISO occurrence form CG 00 01 10/93 or equivalent, covering premises operations, fire damage, independent contractors, products and completed operations, blanket liability, personal injury, and advertising liability with minimum limits as follows:

General Aggregate	\$1,000,000
Each Occurrence	\$1,000,000
Products & Completed Operations Aggregate	\$1,000,000
Any One Fire	\$50,000

If any aggregate limit is reduced below \$1,000,000 because of claims made or paid, GRANTEE shall immediately obtain additional insurance to restore the full aggregate limit and furnish to Adams County a certificate or other document satisfactory to Adams County showing compliance with this provision.

**Automobile Liability Insurance:** To include all motor vehicles owned, hired, leased, or borrowed:

Bodily Injury/Property Damage	\$1,000,000 (each accident combined single limit)
Personal Injury Protection	per Colorado Statutes

**Worker's Compensation:** Worker's Compensation Insurance as required by State statute, and Employer's Liability insurance covering all of GRANTEE employees acting within the course and scope of their employment.



## PUBLIC HEARING AGENDA ITEM

<b>DATE OF PUBLIC HEARING:</b> February 23, 2021
<b>SUBJECT:</b> Approval of CSBG Agreement between Adams County and Growing Home
<b>FROM:</b> Katie Griego, Human Services Director
<b>AGENCY/DEPARTMENT:</b> Human Services
<b>HEARD AT STUDY SESSION ON</b>
<b>AUTHORIZATION TO MOVE FORWARD:</b> <input type="checkbox"/> YES <input type="checkbox"/> NO
<b>RECOMMENDED ACTION:</b> That the Board of County Commissioners Approves of the CSBG Agreement between Adams County and Growing Home

### **BACKGROUND:**

Adams County has received Community Services Block Grant funds to ameliorate the effects of poverty in local communities from the State Department of Local Affairs (DOLA) since 1974. On September 22, 2020, the Community Action Plan and 2021 budget was approved, which included \$306,000 to be allocated to sub-grantees. Community Services Block Grant Advisory Council respectfully recommends funding Growing Home for \$86,000.

The recommendation is to approve the 2020 Agreement with Growing Home.

### **AGENCIES, DEPARTMENTS OR OTHER OFFICES INVOLVED:**

Human Services  
Growing Home

### **ATTACHED DOCUMENTS:**

2021 Growing Home Resolution  
2021 Growing Home Agreement

**FISCAL IMPACT:**

Please check if there is no fiscal impact . If there is fiscal impact, please fully complete the section below.

**Fund:** 34

**Cost Center:** 951016.8810

	<b>Object Account</b>	<b>Subledger</b>	<b>Amount</b>
Current Budgeted Revenue:	5335		\$306,000
Additional Revenue not included in Current Budget:	5335		\$0
<b>Total Revenues:</b>			<u>\$306,000</u>

	<b>Object Account</b>	<b>Subledger</b>	<b>Amount</b>
Current Budgeted Operating Expenditure:	8810		\$306,000
Add'l Operating Expenditure not included in Current Budget:	8810		\$0
Current Budgeted Capital Expenditure:			
Add'l Capital Expenditure not included in Current Budget:			
<b>Total Expenditures:</b>			<u>\$306,000</u>

**New FTEs requested:**                       YES                       NO

**Future Amendment Needed:**                       YES                       NO

**Additional Note:**

We are requesting \$86,000 of the CSBG CARES Act funds be allocated to Growing Home.

BOARD OF COUNTY COMMISSIONERS FOR  
ADAMS COUNTY, STATE OF COLORADO

RESOLUTION APPROVING COMMUNITY SERVICES BLOCK GRANT SUBGRANTEE  
AGREEMENT BETWEEN ADAMS COUNTY AND GROWING HOME

Resolution 2021

WHEREAS, the Federal Government has established the Community Services Block Grant Program (“CSBG”) to provide a range of services and activities designed to have an impact on the causes of poverty in local communities; and,

WHEREAS, U.S Department of Health and Human Services allocates Community Services Block Grant funds to the State of Colorado, Department of Local Affairs through an annual formula allocation; and,

WHEREAS, the CSBG Community Action Plan and 2021 budget was approved by the Adams County Board of County Commissioners on September 22, 2020, which included \$306,000 to be allocated to sub-grantees annually; and,

WHEREAS, the Community Services Block Grant Advisory Council recommends Growing Home to receive \$86,000; and,

WHEREAS, the project award will continue to be included as part of the 2021-2023 Adams County Community Action Plan to the State of Colorado, Department of Local Affairs.

NOW THEREFORE, BE IT RESOLVED, by the Board of County Commissioners, County of Adams, State of Colorado, that Community Services Block Grant Subgrantee Agreement between Adams County and Growing Home, a copy of which is attached hereto and incorporated herein by reference, be and hereby is approved.

BE IT FURTHER RESOLVED, that the Chair of the Board of County Commissioners is hereby authorized to execute said Subgrantee Agreement and any attending documents on behalf of Adams County.

**COMMUNITY SERVICES BLOCK GRANT  
2021 – 2023 AGREEMENT**

For Performance of a Community Services Block Grant Activity  
Catalog of Federal Domestic Assistance (CFDA) Number: 93.569

**ARTICLE I: GENERAL PROVISIONS**

**PARTIES TO THIS AGREEMENT:** This Agreement, dated for reference purposes only this 1<sup>st</sup> day of January, 2021, by and between Adams County, a body politic and corporate, known hereafter as “COUNTY”, and Growing Home, located at 3489 W. 72<sup>nd</sup> Ave. Suite 112 Westminster, CO 80022, known hereafter as the GRANTEE”.

**WHEREAS**, the COUNTY requires the provision of certain services and products in connection with the program funded by grants from the Community Services Block Grant (CSBG) and which must conform to one or more of the following objectives (“Program”):

- A. To provide a range of services and activities having a measurable and potentially major impact on causes of poverty in the community or those areas of the community where poverty is a particularly acute problem.
- B. To provide activities designed to assist low-income participants;
  - (i) to secure and retain meaningful employment;
  - (ii) to attain an adequate education and cognitive development;
  - (iii) to make better use of available income and/or asset building;
  - (iv) to obtain and maintain adequate housing and a suitable living environment;
  - (v) to obtain emergency assistance to meet immediate and urgent individual and family needs, including the need for health and social/behavioral development services, nutritious food, housing, and employment-related assistance;
  - (vi) to remove obstacles and solve problems which block the achievement of self-sufficiency;
  - (vii) to achieve greater participation in the affairs of the community through civic engagement and community involvement; and
  - (viii) to make effective use of other related programs such as agency capacity building.
- C. To provide on an emergency basis for the provision of such supplies and services, nutritious food and related services, as may be necessary to counteract conditions of starvation and malnutrition among the poor;
- D. To coordinate and establish linkages between governmental and other social services programs to assure the effective delivery of such services to low-income individuals;
- E. To encourage the use of entities in the private sector of the community in efforts to ameliorate poverty in the community.

**WHEREAS**, the Community Services Block Grant Advisory Council (CSBGAC) has recommended that the services and products provided for herein be included in the COUNTY’s Application and Community Action Plan to the State for CSBG funds (“Project Plan”); and

**WHEREAS**, the GRANTEE is qualified to provide the services and products as identified in this Agreement.

**NOW, THEREFORE**, in consideration of the mutual promises, payments and other provisions hereof, the

parties agree as follows:

## **ARTICLE II: SCOPE OF SERVICES**

Section 1. The COUNTY hereby agrees to engage the GRANTEE, and the GRANTEE agrees to provide the following services and products as described in the attached Exhibit 1 Scope of Services (“Services”). The Services shall be provided to individuals and families at or below 125% of “poverty income” as defined annually by the United States Department of Health & Human Services only to Adams County residents. Income eligibility and address verification information must be collected and kept in each CSBG customer file.

Section 2. The GRANTEE covenants that it has, or will obtain at its own expense, all personnel, goods, services and equipment required to perform the Services and shall use no funds provided hereunder for any expense other than those expenses required to perform the Services and that are outlined in this agreement.

Section 3. All Services provided hereunder shall be performed by the GRANTEE. No personnel engaged in the performance of those Services shall be employees of the COUNTY, nor shall any personnel providing those Services have any contractual relationship with the COUNTY.

Section 4. The COUNTY reserves the right to enter into other contracts related to the Services, and the GRANTEE agrees to cooperate with the COUNTY and its other contractors with respect to the coordination of those Services.

## **ARTICLE III: DURATION OF CONTRACT**

Section 1. Services provided hereunder shall commence on: January 1, 2021 and shall continue through December 31, 2021, (the “Period of Performance”). The agreement shall be automatically renewed up until July 30, 2024 providing satisfactory service is given and all terms and conditions of this Agreement have been fulfilled. Such extensions must be mutually agreed upon and is contingent upon federal funding from the United States Department of Health & Human Services through the Colorado Department of Local Affairs, known hereafter as “DOLA”.

Section 2. If the GRANTEE fails to comply with any contractual provision, the COUNTY, may, after notice to the GRANTEE, suspend the Agreement and withhold further payment or prohibit the GRANTEE from incurring additional obligation of contractual funds, pending corrective action by the GRANTEE or a decision by the COUNTY to terminate in accordance with this Agreement. The COUNTY may determine to allow such necessary and proper costs which the GRANTEE could not reasonably avoid during the period of suspension.

Section 3. If, through any cause, either party shall fail to honor or otherwise fulfill any of the promises, covenants, obligations, agreements or stipulations of this Agreement, the other party shall have the right to terminate this Agreement by giving ten (10) days written notice to the other party of such termination, specifying the reasons for such termination and the effective date thereof. In the event the GRANTEE is terminated under this section, the GRANTEE shall not be relieved of liability to the COUNTY or the State for any damages sustained by the COUNTY or the State by virtue of any breach of this Agreement by the GRANTEE, and the COUNTY or the State may withhold any payment to the GRANTEE for the purpose of settlement until such time as the exact damage due the COUNTY from the GRANTEE is determined.

Section 4. In addition to other specified remedial actions, the State or COUNTY may exercise the following remedial actions should it find that the GRANTEE substantially failed to satisfy or perform the duties and obligations in this Agreement. Substantial failure to satisfy the duties and obligations shall be defined to mean insufficient, incorrect, improper activities or inaction by the GRANTEE. These remedial actions are as follows:



- 1) Withhold payment to the GRANTEE until the necessary services or corrections in performance are satisfactorily completed;
- 2) Request the removal from work on the Agreement of employees of the GRANTEE whom the COUNTY or the State justifies as being incompetent, careless, insubordinate, unsuitable, or otherwise unacceptable, or whose continued employment on the Agreement it deems to be contrary to the public interest or not in the best interest of the COUNTY or the State;
- 3) Deny payment for those services or obligations which have not been performed and which due to circumstances caused by the GRANTEE cannot be performed or if performed would be of no value to the COUNTY or the State. Denial of the amount of payment must be reasonably related to the amount of work or performance lost to the COUNTY or the State;

or

- 4) Terminate the Agreement for cause.

Section 5. The parties hereto may terminate this Agreement by mutual consent by setting forth in writing the terms, conditions and effective date of such termination, in which case the GRANTEE shall be reimbursed an amount equal to actual eligible expenses incurred as of the date of termination.

Section 6. If the State terminates the COUNTY's Contract with the State as identified in Article V, Section 8, whether for the convenience of the State or for cause, this Agreement shall immediately terminate. If such termination is for cause due to GRANTEE's failure of performance, the provisions of Article III, Section 3, 4, 7, and 8 shall apply and the GRANTEE shall not be relieved of liability to the COUNTY for any damages sustained by the COUNTY by virtue of any breach of the Contract by the GRANTEE, and the COUNTY may withhold any payment to the GRANTEE for the purpose of settlement until such time as the exact damage due the COUNTY from the GRANTEE is determined. If such termination is for the convenience of the State, the GRANTEE shall be reimbursed in an amount equal to actual expenses incurred as of the date of termination.

Section 7. The COUNTY without cause may terminate this Agreement at any time if written notice to terminate is provided to the GRANTEE more than ten (10) days prior to the effective date of the termination. In such event, the GRANTEE shall be paid for all eligible work satisfactorily completed commensurate with the amount of work done on the Scope of Services up to the date of termination less all amounts previously paid, and in addition thereto, any other amount as mutually agreed upon by the parties for the documented direct and incidental termination expenses due to the termination.

Section 8. Should the COUNTY terminate this Agreement for cause, as provided in Section 3 above, no further payments shall be due to the GRANTEE, including payment for Services provided prior to the effective date of termination.

Section 9. Nothing herein shall preclude either party from pursuing such remedies at law or at equity as may be appropriate.

Section 10. If this Agreement is terminated for cause, all finished or unfinished documents, data, studies, surveys, drawings, maps, models, photographs, and reports or other material prepared by the GRANTEE under this Agreement shall, at the option of the COUNTY, become the COUNTY's property, and the GRANTEE shall be entitled to receive just and equitable compensation for any satisfactory work completed on such documents and other materials.

#### **ARTICLE IV: COMPENSATION AND PROJECT BUDGET**

Section 1. The COUNTY shall reimburse the GRANTEE for the actual cost of Services provided hereunder, however, such reimbursement shall not exceed Eighty-Six Thousand Dollars and 00/100 (\$86,000) over the Period of Performance/per year.

- A. Funds under this Agreement shall be spent as set forth in the "Project Budget" attached hereto as Exhibit 2 and incorporated herein by reference.
- B. The GRANTEE shall adhere to the Project Budget as set forth more specifically in subparagraph (A) above to the fullest practicable extent, but the GRANTEE is not precluded from making minor changes within the Scope of Services and Project Budget as necessary, when preapproved by the COUNTY.

Section 2. The COUNTY shall invoice DOLA for payments due and may make payment to the GRANTEE before the receipt of such DOLA CSBG funds for the purpose of the continuation of Services provided in accordance with the State CSBG Plan, the State of Colorado Local Government Financial Management Manual and this Agreement.

Section 3. The parties hereto recognize that compensation paid to the GRANTEE hereunder is funded from CSBG. If funding is not secured under CSBG, or if compensation to the GRANTEE is disapproved thereunder, then this Agreement shall be null and void and no payment will be due the GRANTEE from the COUNTY. Furthermore, if, for any reason, reimbursements from CSBG CARES Act to the COUNTY are delayed, payments to the GRANTEE by the COUNTY may be delayed for the same length of time.

Section 4. GRANTEE acknowledges and is hereby given notice that the financial obligations of the COUNTY under this Agreement, payable after the current fiscal year, are contingent upon funds for this Agreement being appropriated, budgeted and otherwise made available for each fiscal year thereafter. In the event it is determined that funds will not be budgeted and appropriated, the COUNTY may terminate this Agreement by giving GRANTEE notice of such non-appropriation. The COUNTY's fiscal year commences January 1 and ends December 31.

Section 5. If the COUNTY makes any payments for all or any portion of the Services done by the GRANTEE prior to the COUNTY receiving payment from the State and the COUNTY is notified by the State that the State will not reimburse the COUNTY for the services provided by the GRANTEE, the GRANTEE agrees to repay the COUNTY within thirty (30) days of receipt of notice from the COUNTY that the funds must be repaid to the COUNTY.

#### **ARTICLE V: ASSURANCES**

Section 1. The GRANTEE will not discriminate against any employee or applicant for employment, or against any applicant for services or benefits because of race, color, religion, sex or national origin except to the extent that the religious organization exemption provided under 702 of the Civil Rights Act of 1964 (42 U.S.C. 2000e-1) applies. The GRANTEE shall adhere to acceptable affirmative action guidelines in selecting employees, and shall ensure that employees are treated equally during employment without regard to race, religion, sex or national origin. Such action shall include, but is not limited to the following: employment, upgrading, demotion or transfer, recruitment or recruitment advertising, layoff or termination, rates of pay and other compensation and selection for training, including apprenticeship. Furthermore, the GRANTEE will not discriminate on the grounds of race, color, sex or national origin in the selection and retention of its own grantees or contractors, including suppliers of materials and lessors of equipment. Any prohibition against discrimination on the basis of age under the Age Discrimination Act of 1975 or with regard to otherwise qualified disabled individuals as provided in Section 504 of the Rehabilitation Act of 1973 or the Americans

with Disabilities Act shall also apply to the Services provided herein. The GRANTEE agrees to take positive steps to comply and advance in employment qualified disabled persons and to comply with applicable U.S. Department of Health and Human Services Regulations (45 CFR Part 84). GRANTEE agrees to indemnify and hold harmless the COUNTY and the State of Colorado from any claims or demands which may arise under this provision.

Section 2. The GRANTEE shall not compel any employee or volunteer in performing the work of this Agreement to work in surroundings or under working conditions which are unsanitary or dangerous or hazardous to his or her health or safety.

Section 3. The GRANTEE shall comply with Executive Order No. 11426 entitled "Equal Employment Opportunity" as supplemented in the Department of Labor Regulations (41 CFR Section 84) and to execute such provisions as may be required.

Section 4. Independent Contractor/GRANTEE and Indemnification.

- A. In performing the Work, the GRANTEE acts as an independent contractor responsible for calculating, withholding, and paying all Federal and State taxes and for obtaining necessary and adequate Workers Compensation Insurance, general liability insurance and any other insurance required under this Agreement. GRANTEE employees are not and shall not become employees, agents or servants of the COUNTY hereunder. The GRANTEE and GRANTEE employees are not entitled to unemployment insurance benefits unless unemployment compensation coverage is provided by the GRANTEE or some other entity and the GRANTEE is obligated to pay Federal and State income tax on any monies paid pursuant to this Agreement.
- B. The GRANTEE shall indemnify, save and hold harmless the State and the COUNTY, and their employees, officials, board members, officers and agents, against any and all claims, losses, injuries, damages, expenses, liability and court awards including costs, expenses, and attorney fees incurred as a result of any act or omission by the GRANTEE, or its employees, agents, subcontractors, or assignees pursuant to the terms of this Agreement. This indemnification provision shall survive completion of the services and termination of this Agreement. Nothing herein shall be construed as a waiver of defenses available to the COUNTY under the Governmental Immunity Act.

Section 5. The GRANTEE shall comply with all applicable State and Federal laws, rules, regulations and Executive Orders of the Governor of Colorado, involving non-discrimination on the basis of race, color, religion, national origin, age, handicap, or sex. GRANTEE may utilize the expertise of the State Minority Business Office within the Office of the Governor, for assistance in complying with the non-discrimination and affirmative action requirements of this Agreement and applicable statutes.

Section 6. The GRANTEE shall not utilize any funds provided through this Program for political activities.

Section 7. The GRANTEE shall not utilize any funds provided through this Program to provide voters and prospective voters with transportation to the polls or provide similar assistance in connection with an election or any voter registration activity.

Section 8. The GRANTEE shall comply with all applicable State and Federal laws, rules, circulars, guidelines, regulations and requirements and all obligations imposed on the COUNTY or its subcontractors in the COUNTY's Contract with the State of Colorado, Department of Local Affairs for the CSBG program; the Special Provisions attached and incorporated therein; the Federal Terms and Conditions and Assurance in Appendices thereto; and any special conditions incorporated into or attached to a grant award letter which covers funds paid to the GRANTEE. The terms and conditions of that Contract and the Special Provisions are applicable to

this Agreement and are made a part hereof and incorporated herein by reference, whether or not attached hereto. The GRANTEE agrees that it shall cooperate with the COUNTY in the compliance by the COUNTY of all the requirements set forth in the Certifications attached hereto as Exhibit 4 and incorporated herein by reference. The GRANTEE by execution of this Agreement hereby makes the applicable assurances and certifications set forth in the Certifications attached hereto as Exhibit 4.

Section 9. The GRANTEE covenants that it presently has no interest and shall not acquire any interest, direct or indirect, which would conflict in any manner or degree with the performance of Services required to be performed under this Agreement. The GRANTEE further covenants that in the performance of this Agreement no person having any such interest will be employed.

Section 10. The GRANTEE assures that it shall comply with Public Law 101-121, Section 319, 29 CFR Part 93, restrictions on lobbying.

Section 11. The GRANTEE shall ensure compliance with the Drug-Free Workplace Requirements for Federal Grant Recipients under Sections 5153-5158 of the Anti-Drug Abuse Act of 1988 (41 U.S.C. 702-707).

Section 12. The GRANTEE will ensure compliance with Public Law 103.227, Part C-Environmental Tobacco Smoke, also known as the Pro-Children Act of 1994 (Act). This Act requires that smoking may not be permitted in any portion of any indoor facility owned or leased or contracted by an entity and used routinely or regularly for the provision of health, day care, education or library services to children under the age of 18, if the services are funded by Federal programs either directly or through State or local governments. The above requirement will be included in any subawards which contain provisions for children's services and that all subcontractors shall certify compliance accordingly.

Section 13. The GRANTEE shall indemnify, save and hold harmless the State and the COUNTY, and their employees and agents, against any and all claims, damages, liability and court awards including costs, expenses, and attorney fees incurred as a result of any act or omission by the GRANTEE, or its employees, agents, subcontractors, or assignees pursuant to the terms of this Agreement. This indemnification provision shall survive completion of the services termination of this Agreement. Nothing herein shall be construed as a waiver of defenses available to the COUNTY under the Governmental Immunity Act.

#### **ARTICLE VI: CONTINGENT FUNDING**

The parties hereto agree that should the State of Colorado or the Federal government disapprove this Agreement or refuse or fail to make the grant to the COUNTY as contemplated by this Agreement, then this Agreement shall be void and shall not be binding on any party to it. Unearned payments hereunder may be suspended or terminated in the event the GRANTEE refuses to accept additional terms or conditions to this Agreement that may be imposed by the Federal government, the COUNTY, or the State of Colorado after the effective date hereof.

#### **ARTICLE VII: RECORDS, REPORTS, AUDITS AND INSPECTIONS**

Section 1. The GRANTEE shall permit the COUNTY, and State and Federal representatives, to inspect, examine, copy or mechanically reproduce, on or off premises, as deemed necessary for grant purposes, all records pertaining to this Agreement for its term and for a period of five (5) years after its final payment hereunder or for such further period as may be necessary to resolve any matters which may be pending.

Section 2. The GRANTEE is subject to all procurement, fiscal and Program requirements to which the COUNTY is subject under the CSBG grant, including pertinent Federal and State guidelines including OMB Uniform Guidance (2CFR 200) requirements for Non Profit Organizations.

Section 3. The GRANTEE will follow the COUNTY's rules and procedures for reporting expenditures, travel, per

diem expenses, purchases and bid procedures.

Section 4. During the Agreement term, the retention period set forth in Section 1 above, and as long thereafter as records are maintained, at any time during normal business hours, the authorized representatives of the COUNTY, the State of Colorado, and Comptroller General of the United States shall have the right of access to any books, documents, papers or other records of the GRANTEE with respect to all matters covered by this Agreement in order to make audits, investigations, inspections, examinations, excerpts, and transcripts.

Section 5. For work performed under this Agreement the GRANTEE shall cause an audit to be conducted and submitted to the COUNTY in accordance with the applicable requirements in the OMB Super Circular. If an audit is not required in accordance with OMB Super Circular, the GRANTEE shall provide a year-end financial statement for each fiscal year in which the GRANTEE has received funding for this project.

The audits or financial statement shall be furnished to the COUNTY within six (6) months after the end of the GRANTEE's fiscal year.

Section 6. The GRANTEE shall provide to the COUNTY a CSBG Semiannual Performance Report summarizing the Services which includes activities, progress, outcomes, and number of clients served (report format will be provided). The GRANTEE shall provide the COUNTY an Annual Report (report format to be provided) summarizing the Services which include activities, progress, outcomes, and number of clients served by **January 31st of each year**. The GRANTEE shall provide the COUNTY a monthly payment request on the 10<sup>th</sup> of each month. GRANTEE shall meet all other reporting requirements in accordance with the State CSBG Plan and the Local Government Financial Management Manual and any other reporting requirements required by the COUNTY, Federal government or the Colorado Department of Local Affairs. The submission of reports in a timely manner shall be the responsibility of the GRANTEE and failure to comply may result in a delay of payment of funds or termination of this Agreement.

Section 7. The GRANTEE shall follow all State of Colorado Local Government Financial Management Manual financial rules and procedures including, but not limited to, procedures for accounting, reporting, expenditures, and budgeting. Minimum standards to be adhered to are those contained in the Local Government Financial Management Manual.

Section 8. In the event the GRANTEE shall obtain access to any records or files of the State or COUNTY in connection with, or during the performance of, this contract, the GRANTEE shall keep such records and information confidential and shall comply with all laws and regulations concerning the confidentiality of such records to the same extent as such laws and regulations apply to the State or the COUNTY. The GRANTEE agrees to notify and advise in writing all employees, agents, consultants, licensees, or sub-contractors of the said requirements of confidentiality and of possible penalties and fines imposed for violation thereof, and secure from each an acknowledgment of such advisement and agreement to be bound by the terms of this agreement as an employee, agent, consultant, licensee, or sub-contractor of the GRANTEE, as the case may be. Any breach of confidentiality by the GRANTEE or third-party agents of the GRANTEE shall constitute good cause for the COUNTY or the State to cancel this contract without liability; any and all information delivered to the GRANTEE shall be returned to the COUNTY. Any COUNTY or State waiver of an alleged breach of confidentiality by the GRANTEE or third-party agent of the GRANTEE is not to imply a waiver of any subsequent breach.

Section 9. All costs charged to the contract must be documented. For example, the GRANTEE must maintain signed time and attendance records for each and every individual employee and payroll documents approved by an official of the organization. Individual time distribution records must be maintained for allocating an employee's salary between this contract and other funding sources. Source documentation must be maintained for other costs such as receipts, travel vouchers, invoices, bills, or affidavits. Volunteer costs must be documented. All in-kind and other matching contributions, including grant award documents and receipts from other funding sources must be documented.

**ARTICLE VIII: AMENDMENTS**

Section 1. This Agreement contains the entire understanding between the parties. Either party to this Agreement may request Amendments to this Agreement at any time, but no change shall be binding unless it is mutually agreed upon by the parties to this Agreement. All Amendments shall be in writing, authorized and executed prior to any work being done thereon and will be contingent upon Adams County approval.

Section 2. Any change in or new Federal, State or local law, rule, Executive Order, Office of Management & Budget Circular, or other regulation under which the Services are to be performed which may constitutionally be applied to the Services and which, by its terms, is intended to be applied to the Services, shall be deemed to be incorporated into this Agreement.

**ARTICLE IX: APPLICABLE LAWS**

Section 1. The parties hereto agree that this Agreement shall be governed by and construed according to the laws of the State of Colorado.

Section 2. The courts of the State of Colorado shall have sole and exclusive jurisdiction of any disputes or litigation arising hereunder. Venue for any and all legal actions arising hereunder shall lie in the District Court in and for Adams County, State of Colorado.

Section 3. The GRANTEE specifically agrees to comply in the performance hereof with all local, State and Federal ordinances, codes, laws, rules, regulations, orders, and guidelines that are referenced herein and applicable to the Services or that may be or become applicable to the Services even though not stated herein, as described in the attached Exhibit 3 ("Certifications").

**ARTICLE X: NON-ASSIGNMENT**

The GRANTEE represents, covenants and warrants that it will not assign its rights nor delegate its obligations hereunder and breach of this provision shall void the obligations of the COUNTY hereunder as of the date of breach and this Agreement shall be void as of said date.

**ARTICLE XI: SUCCESSORS**

The GRANTEE covenants that the provisions of this Agreement shall be binding upon its successors and agents.

**ARTICLE XII: REPRESENTATIVES**

All applicable invoices, statements, notices, inquiries, and replies shall be addressed and served upon the respective representatives at the addresses below. The following individuals are designated for the purposes of this Agreement as representatives of the COUNTY and the GRANTEE (or their successors or assigns), respectively:

Adams County Attorney's Office 4430 S. Adams County Parkway Brighton, Colorado 80601 Phone: 720-523-6116 Fax: 720-523-6114
Adams County Human Services Contact: Carol Johnson, Specialty Programs Administrator

Address: 11860 Pecos St. Westminster, CO 80234 Phone: 720-523-2154 E-mail: <a href="mailto:cajohnson@adcogov.org">cajohnson@adcogov.org</a>
GRANTEE NAME: Growing Home Contact: Karen Fox Elwell Address: 3489 W. 72 <sup>nd</sup> Ave. Suite 112 Westminster, CO 80030 Phone: 720-407-1974 E-mail: karen@growinghome.org

The parties may change their representatives at any time by written notice to the other party.

**ARTICLE XIII: ILLEGAL ALIENS**

Section 1. COMPLIANCE WITH C.R.S. § 8-17.5-101, ET. SEQ. AS AMENDED 5/13/08: Pursuant to Colorado Revised Statute (C.R.S.), § 8-17.5-101, *et. seq.*, as amended 5/13/08, the Contractor shall meet the following requirements prior to signing this Agreement (public contract for service) and for the duration thereof:

- 1.1. The Contractor shall certify participation in the E-Verify Program (the electronic employment verification program that is authorized in 8 U.S.C. § 1324a and jointly administered by the United States Department of Homeland Security and the Social Security Administration, or its successor program) or the Department Program (the employment verification program established by the Colorado Department of Labor and Employment pursuant to C.R.S. § 8-17.5-102(5)) on the attached certification.
- 1.2. The Contractor shall not knowingly employ or contract with an illegal alien to perform work under this public contract for services.
- 1.3. The Contractor shall not enter into a contract with a subcontractor that fails to certify to the Contractor that the subcontractor shall not knowingly employ or contract with an illegal alien to perform work under this public contract for services.
- 1.4. At the time of signing this public contract for services, the Contractor has confirmed the employment eligibility of all employees who are newly hired for employment to perform work under this public contract for services through participation in either the E-Verify Program or the Department Program.
- 1.5. The Contractor shall not use either the E-Verify Program or the Department Program procedures to undertake pre-employment screening of job applicants while this public contract for services is being performed.
- 1.6. If Contractor obtains actual knowledge that a subcontractor performing work under this public contract for services knowingly employs or contracts with an illegal alien, the Contractor shall: notify the subcontractor and the County within three days that the Contractor has actual knowledge that the subcontractor is employing or contracting with an illegal alien; and terminate the subcontract with the subcontractor if within three days of receiving the notice required pursuant to the previous paragraph, the subcontractor does not stop employing or contracting with the illegal alien; except that the contractor shall not terminate the contract with the subcontractor if during such three days the subcontractor provides information to establish that the subcontractor has not knowingly employed or contracted with an illegal alien.
- 1.7. Contractor shall comply with any reasonable requests by the Department of Labor and

Employment (the Department) made in the course of an investigation that the Department is undertaking pursuant to the authority established in C.R.S. § 8-17.5-102(5).

- 1.8. If Contractor violates this Section of this Agreement, the County may terminate this Agreement for breach of contract. If the Agreement is so terminated, the Contractor shall be liable for actual and consequential damages to the County.

Section 2. GRANTEE must confirm that any individual resides in Adams County, when such individual applies for public benefits provided under this Agreement.

#### **ARTICLE XIV: OFFICIALS NOT TO BENEFIT**

Section 1. No member of the COUNTY government, Commissioners or individual officers elected therein, shall be admitted to any share or part of this Agreement or any benefit that may arise there from.

Section 2. Nothing in this Agreement is intended to create rights in any third-party beneficiary.

#### **ARTICLE XV: SEVERABILITY**

The declaration by any court or other binding legal authority that any provision of this Agreement is illegal and void shall not affect the legality and enforceability of any other provision of this Agreement unless said provisions are mutually dependent.

#### **ARTICLE XVI: ADVERTISEMENT AND PUBLIC NOTICES**

GRANTEE shall ensure that any radio or television announcements, newspaper advertisements, press releases, pamphlets, mail campaigns, or any other method advising the public of their program that is funded with CSBG funds includes the following statement when feasible: "The funding source for this activity is Community Service Block Grant Funds made available through the Human Services Department of Adams County, Colorado."



**CONTRACTOR'S CERTIFICATION OF COMPLIANCE**

Pursuant to Colorado Revised Statute, § 8-17.5-101, *et seq.*, as amended 5/13/08, as a prerequisite to entering into a contract for services with Adams County, Colorado, the undersigned Contractor hereby certifies that at the time of this certification, Contractor does not knowingly employ or contract with an illegal alien who will perform work under the attached contract for services and that the Contractor will participate in the E-Verify Program or Department program, as those terms are defined in C.R.S. § 8-17.5-101, *et seq.* in order to confirm the employment eligibility of all employees who are newly hired for employment to perform work under the attached contract for services.

CONTRACTOR:

\_\_\_\_\_  
Company Name

\_\_\_\_\_  
Date

\_\_\_\_\_  
Name (Print or Type)

\_\_\_\_\_  
Signature

\_\_\_\_\_  
Title

Note: Registration for the E-Verify Program can be completed at: <https://www.vis-dhs.com/employerregistration>. It is recommended that employers review the sample "memorandum of understanding" available at the website prior to registering



**EXHIBIT 1**

**SCOPE OF SERVICES  
COMMUNITY SERVICES BLOCK GRANT**

**Services: *Description of Project***

Growing Home will support long-term housing stability for Adams County residents through a combination of housing-focused services paired with resource education/system navigation and wrap-around supports.

**Number of Adams County Residents to be served by CSBG Specific Project per year (at or below 125% of poverty): 200**

**EXHIBIT 2**

Budget Line Items – Activity Costs	Amount of County Funds Requested
Staff Salary and benefits: Housing Stability Assistant, Resource Education Coordinator, Family Success Coach, Housing Stability Coordinator, Strengthening Families Manager, Impact Manager, CPIO, CFOO	\$78,895
Operating supplies/Program Costs	\$7,105
<b>TOTAL EXPENSE BUDGET</b>	<b>\$86,000</b>

**The following back up and source documentation is required to be submitted with monthly payment requests for each eligible expense (additional documentation may be requested to support expenses):**

<b>Eligible expenses:</b>	<b>Required back up and source documentation:</b>
Salary and Benefits:	Copies of signed time allocation sheets and full and complete payroll report, including fringe information clearly demonstrating percentages charged each month.
Operating Supplies/Program Costs	Invoices of supplies by percentage of CSBG cost

### EXHIBIT 3

#### CSBG CERTIFICATIONS

**The grantee assures that activities implemented with CSBG funds will be:**

- used to accomplish the State CSBG Goals and Objectives stated in the State Plan; and
- within the requirements set forth in the Community Services Block Grant Act, Title IV of the Civil Rights Act, the Age Discrimination Act of 1975, the Rehabilitation Act of 1973, Public Law 103-227, Part C, Environmental Tobacco Smoke, also known as the Pro-Children Act of 1994 (Act), Certification Regarding Drug-Free Workplace Requirements, Certification Regarding Lobbying, Certification Regarding Debarment, Suspension, and Other Responsibility Matters - Primary Covered Transactions, Office of Management and Budget (OMB Circular A110 and A122), and the current State of Colorado CSBG Plan.

**The Grantee also assures that it will:**

- specifically consider, in a public meeting the designation of any local public or private entity to carry out the county community service activities under contract with the county, any local community action agency (CAA) which received federal fiscal 1981-82 funding; and
- consider, on the same basis as other non-governmental organizations, religious organizations to provide the CSBG services, so long as the program is implemented in a manner consistent with the Establishment Clause of the first amendment to the Constitution. Grantees shall not discriminate against an organization that provides assistance under, or applies to provide assistance, on the basis that the organization has a religious character. (Please review Sec.679 Operational Rule in the CSBG Act); and
- provide for coordination between community anti-poverty programs and ensure, where appropriate, that emergency energy crisis intervention programs under Title XXVI (relating to low-income home energy assistance) are conducted in such community; and
- provide, on an emergency basis, for the provision of such supplies and services, nutritious foods, and related services, as may be necessary to counteract conditions of starvation and malnutrition among low-income individuals; and
- coordinate, to the extent possible, programs with and form partnerships with other organizations serving low-income residents of the community and members of groups served, including religious organizations, charitable groups, and community organizations; and
- prohibit the purchase or improvement of land, or the purchase, construction, or permanent improvement (other than low-cost residential weatherization or other energy-related home repairs) of any building or facility with CSBG funds; and
- prohibit, including subcontractors, (a) any partisan or nonpartisan political activity or any political activity associated with a candidate, or contending faction or group, in an election for public or party office, (b) any activity to provide voters or prospective voters with transportation to the polls or similar assistance in connection with any such election, or (c) any voter registration activity; and
- prohibit that persons shall, on the basis of race, color, national origin or sex, be excluded from participation in, be denied the benefits of, or be subjected to discrimination under, any program or activity funded in whole or in part with CSBG. Any prohibition against discrimination on the basis of age under the Age Discrimination Act of 1975 (42 U.S.C 6101 et seq.) or with respect to an otherwise qualified individual with a disability as provided in Section 504 of the Rehabilitation Act of 1973 (29 U.S.C. 12131 et seq.) shall also apply to any such program or activity; and
- participate in the Results-Oriented Management and Accountability (ROMA) System, and describe outcome measure to be used to measure performance in promoting self-sufficiency, family stability, and/or community revitalization; and
- make available for public inspection each plan prepared as part of the program planning process. The Grantee may, at its initiative, revise any plan prepared for CSBG funding and shall furnish the revised plan to the Director of the Community Services Block Grant under the Department of Local Affairs. Each plan prepared for submission shall be made available for public inspection within the county and/or service area in such a manner as will facilitate review of, and comments on, the plan; and
- cooperate with the State and/or County, to determine whether grantee performance goals, administrative standards, financial management requirements, and other requirements of the State and County, in conducting monitoring reviews including (1) a full on-site review on an annual basis,

(2) follow-up reviews if grantee fails to meet the goals, standards, and requirement established by the State, and (3) other reviews as appropriate, including reviews of grantee with other programs that have had other federal, State, or local grants terminated for cause; and

- make available appropriate books, documents, papers, and records for inspection, examination, copying, or mechanical reproduction on or off the premises upon reasonable request by the U.S. Controller General, the State, or their authorized representatives should an investigation of the uses of CSBG funds be undertaken; and
- in the case of county governments or grantees which receive a CSBG award in excess of \$100,000, comply with the following three certifications related to the "Limitation on use of appropriated funds to influence certain Federal Contracting and financial transactions (P.L. 101-121, Section 319 and USC Title 31 Section 1352)":
  1. No Federal appropriated funds have been paid or will be paid by or on behalf of the undersigned, to any person for influencing or attempting to influence an officer or employee of any agency, a Member of Congress, an officer or employee of Congress, or an employee of a Member of Congress in connection with the awarding of any Federal contract, continuation, renewal, amendment, or modification of any Federal contract, grant, loan, or cooperative agreement.
  2. If any funds other than Federal appropriated funds have been paid or will be paid to any person for influencing or attempting to influence an officer or employee of any agency, a Member of Congress, an officer or employee of Congress, or any employee of a Member of Congress in connection with this Federal contract, grant, loan, or cooperative agreement, the undersigned shall complete and submit Standard Form LLL, "Disclosure Form to Report Lobbying," in accordance with its instruction.
  3. The undersigned shall require that the language of this certification be included in the award document for subawards at all tiers (including subcontracts, subgrants, and contracts under grants, loans, and cooperative agreements) and that all subrecipients shall certify and disclose accordingly.

**The Grantee certifies to the best of its knowledge and belief, that it and its principals:**

- a) are not presently debarred, suspended, proposed for debarment, declared ineligible, or voluntarily excluded from covered transactions by any Federal department or agency;
- b) have not within a three-year period preceding this proposal been convicted or had a civil judgment rendered against them for commission of fraud or a criminal offense in connection with obtaining, attempting to obtain, or performing a public transaction; violation of Federal or State antitrust statutes or commission of embezzlement, theft, forgery, bribery, falsification or destruction of records, making false statements, or receiving stolen property;
- c) are not presently indicted for otherwise criminally or civilly charged by a governmental entity (Federal, State or local) with commission of any of the offenses enumerated in paragraph (b) of this certification; and
- d) have not within a three-year period preceding this application had one or more public transactions (Federal, State or local) terminated for cause or default.

**The Grantee further certifies that it:**

- a) requires that smoking not be permitted in any portion of any indoor routinely owned or leased or contracted for by an entity and used routinely or regularly for provisions of health, day care, education, or library services to children under the age of 18, if the services are funded by Federal programs either directly or through State or local governments, by Federal grant, contract, loan, or loan guarantee.
- b) that it will require the language of this certification be included in any sub awards which contain provisions for the children's services and that all Subgrantees shall certify accordingly.

*If you are unable to certify to any of the statements in this certification, please attach an explanation to this application.*

SIGNATURE: \_\_\_\_\_

PRINT NAME: \_\_\_\_\_

POSITION TITLE: \_\_\_\_\_

DATE: \_\_\_\_\_

**EXHIBIT 4**

**INSURANCE**

**General Liability Insurance:** Commercial General Liability Insurance written on ISO occurrence form CG 00 01 10/93 or equivalent, covering premises operations, fire damage, independent contractors, products and completed operations, blanket liability, personal injury, and advertising liability with minimum limits as follows:

General Aggregate	\$1,000,000
Each Occurrence	\$1,000,000
Products & Completed Operations Aggregate	\$1,000,000
Any One Fire	\$50,000

If any aggregate limit is reduced below \$1,000,000 because of claims made or paid, GRANTEE shall immediately obtain additional insurance to restore the full aggregate limit and furnish to Adams County a certificate or other document satisfactory to Adams County showing compliance with this provision.

**Automobile Liability Insurance:** To include all motor vehicles owned, hired, leased, or borrowed:

Bodily Injury/Property Damage	\$1,000,000 (each accident combined single limit)
Personal Injury Protection	per Colorado Statutes

**Worker's Compensation:** Worker's Compensation Insurance as required by State statute, and Employer's Liability insurance covering all of GRANTEE employees acting within the course and scope of their employment.





## PUBLIC HEARING AGENDA ITEM

<b>DATE OF PUBLIC HEARING:</b> February 23, 2021
<b>SUBJECT:</b> Approval of CSBG Agreement between Adams County and Project Angel Heart
<b>FROM:</b> Katie Griego, Human Services Director
<b>AGENCY/DEPARTMENT:</b> Human Services
<b>HEARD AT STUDY SESSION ON</b>
<b>AUTHORIZATION TO MOVE FORWARD:</b> <input type="checkbox"/> YES <input type="checkbox"/> NO
<b>RECOMMENDED ACTION:</b> That the Board of County Commissioners Approves of the CSBG Agreement between Adams County and Project Angel Heart

### **BACKGROUND:**

Adams County has received Community Services Block Grant funds to ameliorate the effects of poverty in local communities from the State Department of Local Affairs (DOLA) since 1974. On September 22, 2020, the Community Action Plan and 2021 budget was approved, which included \$306,000 to be allocated to sub-grantees. Community Services Block Grant Advisory Council respectfully recommends funding Project Angel Heart for \$120,000.

The recommendation is to approve the 2020 Agreement with Project Angel Heart.

### **AGENCIES, DEPARTMENTS OR OTHER OFFICES INVOLVED:**

Human Services  
Project Angel Heart

### **ATTACHED DOCUMENTS:**

2021 Project Angel Heart Resolution  
2021 Project Angel Heart Agreement

### **FISCAL IMPACT:**

Please check if there is no fiscal impact . If there is fiscal impact, please fully complete the section below.

<b>Fund:</b> 34
<b>Cost Center:</b> 951016.8810

	Object Account	Subledger	Amount
Current Budgeted Revenue:	5335		\$306,000
Additional Revenue not included in Current Budget:	5335		\$0
<b>Total Revenues:</b>			\$306,000

	Object Account	Subledger	Amount
Current Budgeted Operating Expenditure:	8810		\$306,000
Add'l Operating Expenditure not included in Current Budget:	8810		\$0
Current Budgeted Capital Expenditure:			
Add'l Capital Expenditure not included in Current Budget:			
<b>Total Expenditures:</b>			\$306,000

New FTEs requested:                     YES             NO

Future Amendment Needed:             YES             NO

**Additional Note:**

We are requesting \$120,000 of the CSBG CARES Act funds be allocated to Project Angel Heart.

BOARD OF COUNTY COMMISSIONERS FOR  
ADAMS COUNTY, STATE OF COLORADO

RESOLUTION APPROVING COMMUNITY SERVICES BLOCK GRANT SUBGRANTEE  
AGREEMENT BETWEEN ADAMS COUNTY AND PROJECT ANGEL HEART

Resolution 2021

WHEREAS, the Federal Government has established the Community Services Block Grant Program (“CSBG”) to provide a range of services and activities designed to have an impact on the causes of poverty in local communities; and,

WHEREAS, U.S Department of Health and Human Services allocates Community Services Block Grant funds to the State of Colorado, Department of Local Affairs through an annual formula allocation; and,

WHEREAS, the CSBG Community Action Plan and 2021 budget was approved by the Adams County Board of County Commissioners on September 22, 2020, which included \$306,000 to be allocated to sub-grantees annually; and,

WHEREAS, the Community Services Block Grant Advisory Council recommends Project Angel Heart to receive \$120,000; and,

WHEREAS, the project award will continue to be included as part of the 2021-2023 Adams County Community Action Plan to the State of Colorado, Department of Local Affairs.

NOW THEREFORE, BE IT RESOLVED, by the Board of County Commissioners, County of Adams, State of Colorado, that Community Services Block Grant Subgrantee Agreement between Adams County and Project Angel Heart, a copy of which is attached hereto and incorporated herein by reference, be and hereby is approved.

BE IT FURTHER RESOLVED, that the Chair of the Board of County Commissioners is hereby authorized to execute said Subgrantee Agreement and any attending documents on behalf of Adams County.

**COMMUNITY SERVICES BLOCK GRANT  
2021 – 2023 AGREEMENT**

For Performance of a Community Services Block Grant Activity  
Catalog of Federal Domestic Assistance (CFDA) Number: 93.569

**ARTICLE I: GENERAL PROVISIONS**

**PARTIES TO THIS AGREEMENT:** This Agreement, dated for reference purposes only this 1<sup>st</sup> day of January, 2021, by and between Adams County, a body politic and corporate, known hereafter as “COUNTY”, and Project Angel Heart, located at 4950 Washington St. Denver, CO 80216, known hereafter as the GRANTEE”.

**WHEREAS**, the COUNTY requires the provision of certain services and products in connection with the program funded by grants from the Community Services Block Grant (CSBG) and which must conform to one or more of the following objectives (“Program”):

- A. To provide a range of services and activities having a measurable and potentially major impact on causes of poverty in the community or those areas of the community where poverty is a particularly acute problem.
- B. To provide activities designed to assist low-income participants;
  - (i) to secure and retain meaningful employment;
  - (ii) to attain an adequate education and cognitive development;
  - (iii) to make better use of available income and/or asset building;
  - (iv) to obtain and maintain adequate housing and a suitable living environment;
  - (v) to obtain emergency assistance to meet immediate and urgent individual and family needs, including the need for health and social/behavioral development services, nutritious food, housing, and employment-related assistance;
  - (vi) to remove obstacles and solve problems which block the achievement of self-sufficiency;
  - (vii) to achieve greater participation in the affairs of the community through civic engagement and community involvement; and
  - (viii) to make effective use of other related programs such as agency capacity building.
- C. To provide on an emergency basis for the provision of such supplies and services, nutritious food and related services, as may be necessary to counteract conditions of starvation and malnutrition among the poor;
- D. To coordinate and establish linkages between governmental and other social services programs to assure the effective delivery of such services to low-income individuals;
- E. To encourage the use of entities in the private sector of the community in efforts to ameliorate poverty in the community.

**WHEREAS**, the Community Services Block Grant Advisory Council (CSBGAC) has recommended that the services and products provided for herein be included in the COUNTY’s Application and Community Action Plan to the State for CSBG funds (“Project Plan”); and

**WHEREAS**, the GRANTEE is qualified to provide the services and products as identified in this Agreement.

**NOW, THEREFORE**, in consideration of the mutual promises, payments and other provisions hereof, the parties agree as follows:

## **ARTICLE II: SCOPE OF SERVICES**

Section 1. The COUNTY hereby agrees to engage the GRANTEE, and the GRANTEE agrees to provide the following services and products as described in the attached Exhibit 1 Scope of Services (“Services”). The Services shall be provided to individuals and families at or below 125% of “poverty income” as defined annually by the United States Department of Health & Human Services only to Adams County residents. Income eligibility and address verification information must be collected and kept in each CSBG customer file.

Section 2. The GRANTEE covenants that it has, or will obtain at its own expense, all personnel, goods, services and equipment required to perform the Services and shall use no funds provided hereunder for any expense other than those expenses required to perform the Services and that are outlined in this agreement.

Section 3. All Services provided hereunder shall be performed by the GRANTEE. No personnel engaged in the performance of those Services shall be employees of the COUNTY, nor shall any personnel providing those Services have any contractual relationship with the COUNTY.

Section 4. The COUNTY reserves the right to enter into other contracts related to the Services, and the GRANTEE agrees to cooperate with the COUNTY and its other contractors with respect to the coordination of those Services.

## **ARTICLE III: DURATION OF CONTRACT**

Section 1. Services provided hereunder shall commence on: January 1, 2021 and shall continue through December 31, 2021, (the “Period of Performance”). The agreement shall be automatically renewed up until July 30, 2024 providing satisfactory service is given and all terms and conditions of this Agreement have been fulfilled. Such extensions must be mutually agreed upon and is contingent upon federal funding from the United States Department of Health & Human Services through the Colorado Department of Local Affairs, known hereafter as “DOLA”.

Section 2. If the GRANTEE fails to comply with any contractual provision, the COUNTY, may, after notice to the GRANTEE, suspend the Agreement and withhold further payment or prohibit the GRANTEE from incurring additional obligation of contractual funds, pending corrective action by the GRANTEE or a decision by the COUNTY to terminate in accordance with this Agreement. The COUNTY may determine to allow such necessary and proper costs which the GRANTEE could not reasonably avoid during the period of suspension.

Section 3. If, through any cause, either party shall fail to honor or otherwise fulfill any of the promises, covenants, obligations, agreements or stipulations of this Agreement, the other party shall have the right to terminate this Agreement by giving ten (10) days written notice to the other party of such termination, specifying the reasons for such termination and the effective date thereof. In the event the GRANTEE is terminated under this section, the GRANTEE shall not be relieved of liability to the COUNTY or the State for any damages sustained by the COUNTY or the State by virtue of any breach of this Agreement by the GRANTEE, and the COUNTY or the State may withhold any payment to the GRANTEE for the purpose of settlement until such time as the exact damage due the COUNTY from the GRANTEE is determined.

Section 4. In addition to other specified remedial actions, the State or COUNTY may exercise the following remedial actions should it find that the GRANTEE substantially failed to satisfy or perform the duties and obligations in this Agreement. Substantial failure to satisfy the duties and obligations shall be defined to mean insufficient, incorrect, improper activities or inaction by the GRANTEE. These remedial actions are as follows:

- 1) Withhold payment to the GRANTEE until the necessary services or corrections in performance are

satisfactorily completed;

- 2) Request the removal from work on the Agreement of employees of the GRANTEE whom the COUNTY or the State justifies as being incompetent, careless, insubordinate, unsuitable, or otherwise unacceptable, or whose continued employment on the Agreement it deems to be contrary to the public interest or not in the best interest of the COUNTY or the State;
- 3) Deny payment for those services or obligations which have not been performed and which due to circumstances caused by the GRANTEE cannot be performed or if performed would be of no value to the COUNTY or the State. Denial of the amount of payment must be reasonably related to the amount of work or performance lost to the COUNTY or the State;

or

- 4) Terminate the Agreement for cause.

Section 5. The parties hereto may terminate this Agreement by mutual consent by setting forth in writing the terms, conditions and effective date of such termination, in which case the GRANTEE shall be reimbursed an amount equal to actual eligible expenses incurred as of the date of termination.

Section 6. If the State terminates the COUNTY's Contract with the State as identified in Article V, Section 8, whether for the convenience of the State or for cause, this Agreement shall immediately terminate. If such termination is for cause due to GRANTEE's failure of performance, the provisions of Article III, Section 3, 4, 7, and 8 shall apply and the GRANTEE shall not be relieved of liability to the COUNTY for any damages sustained by the COUNTY by virtue of any breach of the Contract by the GRANTEE, and the COUNTY may withhold any payment to the GRANTEE for the purpose of settlement until such time as the exact damage due the COUNTY from the GRANTEE is determined. If such termination is for the convenience of the State, the GRANTEE shall be reimbursed in an amount equal to actual expenses incurred as of the date of termination.

Section 7. The COUNTY without cause may terminate this Agreement at any time if written notice to terminate is provided to the GRANTEE more than ten (10) days prior to the effective date of the termination. In such event, the GRANTEE shall be paid for all eligible work satisfactorily completed commensurate with the amount of work done on the Scope of Services up to the date of termination less all amounts previously paid, and in addition thereto, any other amount as mutually agreed upon by the parties for the documented direct and incidental termination expenses due to the termination.

Section 8. Should the COUNTY terminate this Agreement for cause, as provided in Section 3 above, no further payments shall be due to the GRANTEE, including payment for Services provided prior to the effective date of termination.

Section 9. Nothing herein shall preclude either party from pursuing such remedies at law or at equity as may be appropriate.

Section 10. If this Agreement is terminated for cause, all finished or unfinished documents, data, studies, surveys, drawings, maps, models, photographs, and reports or other material prepared by the GRANTEE under this Agreement shall, at the option of the COUNTY, become the COUNTY's property, and the GRANTEE shall be entitled to receive just and equitable compensation for any satisfactory work completed on such documents and other materials.

#### **ARTICLE IV: COMPENSATION AND PROJECT BUDGET**

Section 1. The COUNTY shall reimburse the GRANTEE for the actual cost of Services provided hereunder, however, such reimbursement shall not exceed One Hundred and Twenty Thousand Dollars and 00/100 (\$120,000) over the Period of Performance/per year.

- A. Funds under this Agreement shall be spent as set forth in the "Project Budget" attached hereto as Exhibit 2 and incorporated herein by reference.
- B. The GRANTEE shall adhere to the Project Budget as set forth more specifically in subparagraph (A) above to the fullest practicable extent, but the GRANTEE is not precluded from making minor changes within the Scope of Services and Project Budget as necessary, when preapproved by the COUNTY.

Section 2. The COUNTY shall invoice DOLA for payments due and may make payment to the GRANTEE before the receipt of such DOLA CSBG funds for the purpose of the continuation of Services provided in accordance with the State CSBG Plan, the State of Colorado Local Government Financial Management Manual and this Agreement.

Section 3. The parties hereto recognize that compensation paid to the GRANTEE hereunder is funded from CSBG. If funding is not secured under CSBG, or if compensation to the GRANTEE is disapproved thereunder, then this Agreement shall be null and void and no payment will be due the GRANTEE from the COUNTY. Furthermore, if, for any reason, reimbursements from CSBG CARES Act to the COUNTY are delayed, payments to the GRANTEE by the COUNTY may be delayed for the same length of time.

Section 4. GRANTEE acknowledges and is hereby given notice that the financial obligations of the COUNTY under this Agreement, payable after the current fiscal year, are contingent upon funds for this Agreement being appropriated, budgeted and otherwise made available for each fiscal year thereafter. In the event it is determined that funds will not be budgeted and appropriated, the COUNTY may terminate this Agreement by giving GRANTEE notice of such non-appropriation. The COUNTY's fiscal year commences January 1 and ends December 31.

Section 5. If the COUNTY makes any payments for all or any portion of the Services done by the GRANTEE prior to the COUNTY receiving payment from the State and the COUNTY is notified by the State that the State will not reimburse the COUNTY for the services provided by the GRANTEE, the GRANTEE agrees to repay the COUNTY within thirty (30) days of receipt of notice from the COUNTY that the funds must be repaid to the COUNTY.

#### **ARTICLE V: ASSURANCES**

Section 1. The GRANTEE will not discriminate against any employee or applicant for employment, or against any applicant for services or benefits because of race, color, religion, sex or national origin except to the extent that the religious organization exemption provided under 702 of the Civil Rights Act of 1964 (42 U.S.C. 2000e-1) applies. The GRANTEE shall adhere to acceptable affirmative action guidelines in selecting employees, and shall ensure that employees are treated equally during employment without regard to race, religion, sex or national origin. Such action shall include, but is not limited to the following: employment, upgrading, demotion or transfer, recruitment or recruitment advertising, layoff or termination, rates of pay and other compensation and selection for training, including apprenticeship. Furthermore, the GRANTEE will not discriminate on the grounds of race, color, sex or national origin in the selection and retention of its own grantees or contractors, including suppliers of materials and lessors of equipment. Any prohibition against discrimination on the basis of age under the Age Discrimination Act of 1975 or with regard to otherwise qualified disabled individuals as provided in Section 504 of the Rehabilitation Act of 1973 or the Americans with Disabilities Act shall also apply to the Services provided herein. The GRANTEE agrees to take positive

steps to comply and advance in employment qualified disabled persons and to comply with applicable U.S. Department of Health and Human Services Regulations (45 CFR Part 84). GRANTEE agrees to indemnify and hold harmless the COUNTY and the State of Colorado from any claims or demands which may arise under this provision.

Section 2. The GRANTEE shall not compel any employee or volunteer in performing the work of this Agreement to work in surroundings or under working conditions which are unsanitary or dangerous or hazardous to his or her health or safety.

Section 3. The GRANTEE shall comply with Executive Order No. 11426 entitled "Equal Employment Opportunity" as supplemented in the Department of Labor Regulations (41 CFR Section 84) and to execute such provisions as may be required.

Section 4. Independent Contractor/GRANTEE and Indemnification.

- A. In performing the Work, the GRANTEE acts as an independent contractor responsible for calculating, withholding, and paying all Federal and State taxes and for obtaining necessary and adequate Workers Compensation Insurance, general liability insurance and any other insurance required under this Agreement. GRANTEE employees are not and shall not become employees, agents or servants of the COUNTY hereunder. The GRANTEE and GRANTEE employees are not entitled to unemployment insurance benefits unless unemployment compensation coverage is provided by the GRANTEE or some other entity and the GRANTEE is obligated to pay Federal and State income tax on any monies paid pursuant to this Agreement.
- B. The GRANTEE shall indemnify, save and hold harmless the State and the COUNTY, and their employees, officials, board members, officers and agents, against any and all claims, losses, injuries, damages, expenses, liability and court awards including costs, expenses, and attorney fees incurred as a result of any act or omission by the GRANTEE, or its employees, agents, subcontractors, or assignees pursuant to the terms of this Agreement. This indemnification provision shall survive completion of the services and termination of this Agreement. Nothing herein shall be construed as a waiver of defenses available to the COUNTY under the Governmental Immunity Act.

Section 5. The GRANTEE shall comply with all applicable State and Federal laws, rules, regulations and Executive Orders of the Governor of Colorado, involving non-discrimination on the basis of race, color, religion, national origin, age, handicap, or sex. GRANTEE may utilize the expertise of the State Minority Business Office within the Office of the Governor, for assistance in complying with the non-discrimination and affirmative action requirements of this Agreement and applicable statutes.

Section 6. The GRANTEE shall not utilize any funds provided through this Program for political activities.

Section 7. The GRANTEE shall not utilize any funds provided through this Program to provide voters and prospective voters with transportation to the polls or provide similar assistance in connection with an election or any voter registration activity.

Section 8. The GRANTEE shall comply with all applicable State and Federal laws, rules, circulars, guidelines, regulations and requirements and all obligations imposed on the COUNTY or its subcontractors in the COUNTY's Contract with the State of Colorado, Department of Local Affairs for the CSBG program; the Special Provisions attached and incorporated therein; the Federal Terms and Conditions and Assurance in Appendices thereto; and any special conditions incorporated into or attached to a grant award letter which covers funds paid to the GRANTEE. The terms and conditions of that Contract and the Special Provisions are applicable to this Agreement and are made a part hereof and incorporated herein by reference, whether or not attached



hereto. The GRANTEE agrees that it shall cooperate with the COUNTY in the compliance by the COUNTY of all the requirements set forth in the Certifications attached hereto as Exhibit 4 and incorporated herein by reference. The GRANTEE by execution of this Agreement hereby makes the applicable assurances and certifications set forth in the Certifications attached hereto as Exhibit 4.

Section 9. The GRANTEE covenants that it presently has no interest and shall not acquire any interest, direct or indirect, which would conflict in any manner or degree with the performance of Services required to be performed under this Agreement. The GRANTEE further covenants that in the performance of this Agreement no person having any such interest will be employed.

Section 10. The GRANTEE assures that it shall comply with Public Law 101-121, Section 319, 29 CFR Part 93, restrictions on lobbying.

Section 11. The GRANTEE shall ensure compliance with the Drug-Free Workplace Requirements for Federal Grant Recipients under Sections 5153-5158 of the Anti-Drug Abuse Act of 1988 (41 U.S.C. 702-707).

Section 12. The GRANTEE will ensure compliance with Public Law 103.227, Part C-Environmental Tobacco Smoke, also known as the Pro-Children Act of 1994 (Act). This Act requires that smoking may not be permitted in any portion of any indoor facility owned or leased or contracted by an entity and used routinely or regularly for the provision of health, day care, education or library services to children under the age of 18, if the services are funded by Federal programs either directly or through State or local governments. The above requirement will be included in any subawards which contain provisions for children's services and that all subcontractors shall certify compliance accordingly.

Section 13. The GRANTEE shall indemnify, save and hold harmless the State and the COUNTY, and their employees and agents, against any and all claims, damages, liability and court awards including costs, expenses, and attorney fees incurred as a result of any act or omission by the GRANTEE, or its employees, agents, subcontractors, or assignees pursuant to the terms of this Agreement. This indemnification provision shall survive completion of the services termination of this Agreement. Nothing herein shall be construed as a waiver of defenses available to the COUNTY under the Governmental Immunity Act.

#### **ARTICLE VI: CONTINGENT FUNDING**

The parties hereto agree that should the State of Colorado or the Federal government disapprove this Agreement or refuse or fail to make the grant to the COUNTY as contemplated by this Agreement, then this Agreement shall be void and shall not be binding on any party to it. Unearned payments hereunder may be suspended or terminated in the event the GRANTEE refuses to accept additional terms or conditions to this Agreement that may be imposed by the Federal government, the COUNTY, or the State of Colorado after the effective date hereof.

#### **ARTICLE VII: RECORDS, REPORTS, AUDITS AND INSPECTIONS**

Section 1. The GRANTEE shall permit the COUNTY, and State and Federal representatives, to inspect, examine, copy or mechanically reproduce, on or off premises, as deemed necessary for grant purposes, all records pertaining to this Agreement for its term and for a period of five (5) years after its final payment hereunder or for such further period as may be necessary to resolve any matters which may be pending.

Section 2. The GRANTEE is subject to all procurement, fiscal and Program requirements to which the COUNTY is subject under the CSBG grant, including pertinent Federal and State guidelines including OMB Uniform Guidance (2CFR 200) requirements for Non Profit Organizations.

Section 3. The GRANTEE will follow the COUNTY's rules and procedures for reporting expenditures, travel, per diem expenses, purchases and bid procedures.

Section 4. During the Agreement term, the retention period set forth in Section 1 above, and as long thereafter as records are maintained, at any time during normal business hours, the authorized representatives of the COUNTY, the State of Colorado, and Comptroller General of the United States shall have the right of access to any books, documents, papers or other records of the GRANTEE with respect to all matters covered by this Agreement in order to make audits, investigations, inspections, examinations, excerpts, and transcripts.

Section 5. For work performed under this Agreement the GRANTEE shall cause an audit to be conducted and submitted to the COUNTY in accordance with the applicable requirements in the OMB Super Circular. If an audit is not required in accordance with OMB Super Circular, the GRANTEE shall provide a year-end financial statement for each fiscal year in which the GRANTEE has received funding for this project.

The audits or financial statement shall be furnished to the COUNTY within six (6) months after the end of the GRANTEE's fiscal year.

Section 6. The GRANTEE shall provide to the COUNTY a CSBG Semiannual Performance Report summarizing the Services which includes activities, progress, outcomes, and number of clients served (report format will be provided). The GRANTEE shall provide the COUNTY an Annual Report (report format to be provided) summarizing the Services which include activities, progress, outcomes, and number of clients served by **January 31st of each year**. The GRANTEE shall provide the COUNTY a monthly payment request on the 10<sup>th</sup> of each month. GRANTEE shall meet all other reporting requirements in accordance with the State CSBG Plan and the Local Government Financial Management Manual and any other reporting requirements required by the COUNTY, Federal government or the Colorado Department of Local Affairs. The submission of reports in a timely manner shall be the responsibility of the GRANTEE and failure to comply may result in a delay of payment of funds or termination of this Agreement.

Section 7. The GRANTEE shall follow all State of Colorado Local Government Financial Management Manual financial rules and procedures including, but not limited to, procedures for accounting, reporting, expenditures, and budgeting. Minimum standards to be adhered to are those contained in the Local Government Financial Management Manual.

Section 8. In the event the GRANTEE shall obtain access to any records or files of the State or COUNTY in connection with, or during the performance of, this contract, the GRANTEE shall keep such records and information confidential and shall comply with all laws and regulations concerning the confidentiality of such records to the same extent as such laws and regulations apply to the State or the COUNTY. The GRANTEE agrees to notify and advise in writing all employees, agents, consultants, licensees, or sub-contractors of the said requirements of confidentiality and of possible penalties and fines imposed for violation thereof, and secure from each an acknowledgment of such advisement and agreement to be bound by the terms of this agreement as an employee, agent, consultant, licensee, or sub-contractor of the GRANTEE, as the case may be. Any breach of confidentiality by the GRANTEE or third-party agents of the GRANTEE shall constitute good cause for the COUNTY or the State to cancel this contract without liability; any and all information delivered to the GRANTEE shall be returned to the COUNTY. Any COUNTY or State waiver of an alleged breach of confidentiality by the GRANTEE or third-party agent of the GRANTEE is not to imply a waiver of any subsequent breach.

Section 9. All costs charged to the contract must be documented. For example, the GRANTEE must maintain signed time and attendance records for each and every individual employee and payroll documents approved by an official of the organization. Individual time distribution records must be maintained for allocating an employee's salary between this contract and other funding sources. Source documentation must be maintained for other costs such as receipts, travel vouchers, invoices, bills, or affidavits. Volunteer costs must be documented. All in-kind and other matching contributions, including grant award documents and receipts from other funding sources must be documented.

**ARTICLE VIII: AMENDMENTS**

Section 1. This Agreement contains the entire understanding between the parties. Either party to this Agreement may request Amendments to this Agreement at any time, but no change shall be binding unless it is mutually agreed upon by the parties to this Agreement. All Amendments shall be in writing, authorized and executed prior to any work being done thereon and will be contingent upon Adams County approval.

Section 2. Any change in or new Federal, State or local law, rule, Executive Order, Office of Management & Budget Circular, or other regulation under which the Services are to be performed which may constitutionally be applied to the Services and which, by its terms, is intended to be applied to the Services, shall be deemed to be incorporated into this Agreement.

**ARTICLE IX: APPLICABLE LAWS**

Section 1. The parties hereto agree that this Agreement shall be governed by and construed according to the laws of the State of Colorado.

Section 2. The courts of the State of Colorado shall have sole and exclusive jurisdiction of any disputes or litigation arising hereunder. Venue for any and all legal actions arising hereunder shall lie in the District Court in and for Adams County, State of Colorado.

Section 3. The GRANTEE specifically agrees to comply in the performance hereof with all local, State and Federal ordinances, codes, laws, rules, regulations, orders, and guidelines that are referenced herein and applicable to the Services or that may be or become applicable to the Services even though not stated herein, as described in the attached Exhibit 3 ("Certifications").

**ARTICLE X: NON-ASSIGNMENT**

The GRANTEE represents, covenants and warrants that it will not assign its rights nor delegate its obligations hereunder and breach of this provision shall void the obligations of the COUNTY hereunder as of the date of breach and this Agreement shall be void as of said date.

**ARTICLE XI: SUCCESSORS**

The GRANTEE covenants that the provisions of this Agreement shall be binding upon its successors and agents.

**ARTICLE XII: REPRESENTATIVES**

All applicable invoices, statements, notices, inquiries, and replies shall be addressed and served upon the respective representatives at the addresses below. The following individuals are designated for the purposes of this Agreement as representatives of the COUNTY and the GRANTEE (or their successors or assigns), respectively:

Adams County Attorney's Office 4430 S. Adams County Parkway Brighton, Colorado 80601 Phone: 720-523-6116 Fax: 720-523-6114
Adams County Human Services Contact: Carol Johnson, Specialty Programs Administrator Address: 11860 Pecos St. Westminster, CO 80234 Phone: 720-523-2154

E-mail: <a href="mailto:cajohnson@adcogov.org">cajohnson@adcogov.org</a>
GRANTEE NAME: Project Angel Heart Contact: Rachel Rooney Address: 4950 Washington St. Denver, CO 80216 Phone: 303-830-0202 Fax: N/A E-mail: grants@projectangelheart.org

The parties may change their representatives at any time by written notice to the other party.

**ARTICLE XIII: ILLEGAL ALIENS**

Section 1. COMPLIANCE WITH C.R.S. § 8-17.5-101, ET. SEQ. AS AMENDED 5/13/08: Pursuant to Colorado Revised Statute (C.R.S.), § 8-17.5-101, *et. seq.*, as amended 5/13/08, the Contractor shall meet the following requirements prior to signing this Agreement (public contract for service) and for the duration thereof:

- 1.1. The Contractor shall certify participation in the E-Verify Program (the electronic employment verification program that is authorized in 8 U.S.C. § 1324a and jointly administered by the United States Department of Homeland Security and the Social Security Administration, or its successor program) or the Department Program (the employment verification program established by the Colorado Department of Labor and Employment pursuant to C.R.S. § 8-17.5-102(5)) on the attached certification.
- 1.2. The Contractor shall not knowingly employ or contract with an illegal alien to perform work under this public contract for services.
- 1.3. The Contractor shall not enter into a contract with a subcontractor that fails to certify to the Contractor that the subcontractor shall not knowingly employ or contract with an illegal alien to perform work under this public contract for services.
- 1.4. At the time of signing this public contract for services, the Contractor has confirmed the employment eligibility of all employees who are newly hired for employment to perform work under this public contract for services through participation in either the E-Verify Program or the Department Program.
- 1.5. The Contractor shall not use either the E-Verify Program or the Department Program procedures to undertake pre-employment screening of job applicants while this public contract for services is being performed.
- 1.6. If Contractor obtains actual knowledge that a subcontractor performing work under this public contract for services knowingly employs or contracts with an illegal alien, the Contractor shall: notify the subcontractor and the County within three days that the Contractor has actual knowledge that the subcontractor is employing or contracting with an illegal alien; and terminate the subcontract with the subcontractor if within three days of receiving the notice required pursuant to the previous paragraph, the subcontractor does not stop employing or contracting with the illegal alien; except that the contractor shall not terminate the contract with the subcontractor if during such three days the subcontractor provides information to establish that the subcontractor has not knowingly employed or contracted with an illegal alien.
- 1.7. Contractor shall comply with any reasonable requests by the Department of Labor and Employment (the Department) made in the course of an investigation that the Department is undertaking pursuant to the authority established in C.R.S. § 8-17.5-102(5).

- 1.8. If Contractor violates this Section of this Agreement, the County may terminate this Agreement for breach of contract. If the Agreement is so terminated, the Contractor shall be liable for actual and consequential damages to the County.

Section 2. GRANTEE must confirm that any individual resides in Adams County, when such individual applies for public benefits provided under this Agreement.

#### **ARTICLE XIV: OFFICIALS NOT TO BENEFIT**

Section 1. No member of the COUNTY government, Commissioners or individual officers elected therein, shall be admitted to any share or part of this Agreement or any benefit that may arise there from.

Section 2. Nothing in this Agreement is intended to create rights in any third-party beneficiary.

#### **ARTICLE XV: SEVERABILITY**

The declaration by any court or other binding legal authority that any provision of this Agreement is illegal and void shall not affect the legality and enforceability of any other provision of this Agreement unless said provisions are mutually dependent.

#### **ARTICLE XVI: ADVERTISEMENT AND PUBLIC NOTICES**

GRANTEE shall ensure that any radio or television announcements, newspaper advertisements, press releases, pamphlets, mail campaigns, or any other method advising the public of their program that is funded with CSBG funds includes the following statement when feasible: "The funding source for this activity is Community Service Block Grant Funds made available through the Human Services Department of Adams County, Colorado."

**CONTRACTOR'S CERTIFICATION OF COMPLIANCE**

Pursuant to Colorado Revised Statute, § 8-17.5-101, *et seq.*, as amended 5/13/08, as a prerequisite to entering into a contract for services with Adams County, Colorado, the undersigned Contractor hereby certifies that at the time of this certification, Contractor does not knowingly employ or contract with an illegal alien who will perform work under the attached contract for services and that the Contractor will participate in the E-Verify Program or Department program, as those terms are defined in C.R.S. § 8-17.5-101, *et seq.* in order to confirm the employment eligibility of all employees who are newly hired for employment to perform work under the attached contract for services.

CONTRACTOR:

\_\_\_\_\_  
Company Name

\_\_\_\_\_  
Date

\_\_\_\_\_  
Name (Print or Type)

\_\_\_\_\_  
Signature

\_\_\_\_\_  
Title

Note: Registration for the E-Verify Program can be completed at: <https://www.vis-dhs.com/employerregistration>. It is recommended that employers review the sample "memorandum of understanding" available at the website prior to registering



**EXHIBIT 1**

**SCOPE OF SERVICES  
COMMUNITY SERVICES BLOCK GRANT**

**Services: *Description of Project***

Project Angel Heart delivers medically tailored meals, free of charge, to food-insecure Adams County residents living with life-threatening illnesses. Projected per-meal cost for 2021 will not exceed \$9.00.

**Number of Adams County Residents to be served by CSBG Specific Project per year (at or below 125% of poverty): 88**



**EXHIBIT 2**

<b>Budget Line Items – Activity Costs</b>	<b>Amount of County Funds Requested</b>
Our projected per-meal cost over the grant term (CY2021-CY2023) will not exceed \$9.00. If awarded in full, \$120,000 would provide a minimum of 13,334 meals to at least 88 CSBG-eligible Adams County residents for each year that CSBG funds are provided in relation to this proposal	<i>\$120,000</i>
<b>TOTAL (must equal amount being requested)</b>	<b>\$120,000</b>

The following back up and source documentation is required to be submitted with monthly payment requests for each eligible expense (additional documentation may be requested to support expenses):

<b>Eligible expense:</b>	<b>Required back up and source documentation:</b>
Client meals	Copy of 'cost of meal' methodology and report of number of meals provided to Adams County low-income individuals

### EXHIBIT 3

#### CSBG CERTIFICATIONS

**The grantee assures that activities implemented with CSBG funds will be:**

- used to accomplish the State CSBG Goals and Objectives stated in the State Plan; and
- within the requirements set forth in the Community Services Block Grant Act, Title IV of the Civil Rights Act, the Age Discrimination Act of 1975, the Rehabilitation Act of 1973, Public Law 103-227, Part C, Environmental Tobacco Smoke, also known as the Pro-Children Act of 1994 (Act), Certification Regarding Drug-Free Workplace Requirements, Certification Regarding Lobbying, Certification Regarding Debarment, Suspension, and Other Responsibility Matters - Primary Covered Transactions, Office of Management and Budget (OMB Circular A110 and A122), and the current State of Colorado CSBG Plan.

**The Grantee also assures that it will:**

- specifically consider, in a public meeting the designation of any local public or private entity to carry out the county community service activities under contract with the county, any local community action agency (CAA) which received federal fiscal 1981-82 funding; and
- consider, on the same basis as other non-governmental organizations, religious organizations to provide the CSBG services, so long as the program is implemented in a manner consistent with the Establishment Clause of the first amendment to the Constitution. Grantees shall not discriminate against an organization that provides assistance under, or applies to provide assistance, on the basis that the organization has a religious character. (Please review Sec.679 Operational Rule in the CSBG Act); and
- provide for coordination between community anti-poverty programs and ensure, where appropriate, that emergency energy crisis intervention programs under Title XXVI (relating to low-income home energy assistance) are conducted in such community; and
- provide, on an emergency basis, for the provision of such supplies and services, nutritious foods, and related services, as may be necessary to counteract conditions of starvation and malnutrition among low-income individuals; and
- coordinate, to the extent possible, programs with and form partnerships with other organizations serving low-income residents of the community and members of groups served, including religious organizations, charitable groups, and community organizations; and
- prohibit the purchase or improvement of land, or the purchase, construction, or permanent improvement (other than low-cost residential weatherization or other energy-related home repairs) of any building or facility with CSBG funds; and
- prohibit, including subcontractors, (a) any partisan or nonpartisan political activity or any political activity associated with a candidate, or contending faction or group, in an election for public or party office, (b) any activity to provide voters or prospective voters with transportation to the polls or similar assistance in connection with any such election, or (c) any voter registration activity; and
- prohibit that persons shall, on the basis of race, color, national origin or sex, be excluded from participation in, be denied the benefits of, or be subjected to discrimination under, any program or activity funded in whole or in part with CSBG. Any prohibition against discrimination on the basis of age under the Age Discrimination Act of 1975 (42 U.S.C 6101 et seq.) or with respect to an otherwise qualified individual with a disability as provided in Section 504 of the Rehabilitation Act of 1973 (29 U.S.C. 12131 et seq.) shall also apply to any such program or activity; and
- participate in the Results-Oriented Management and Accountability (ROMA) System, and describe outcome measure to be used to measure performance in promoting self-sufficiency, family stability, and/or community revitalization; and
- make available for public inspection each plan prepared as part of the program planning process. The Grantee may, at its initiative, revise any plan prepared for CSBG funding and shall furnish the revised plan to the Director of the Community Services Block Grant under the Department of Local Affairs. Each plan prepared for submission shall be made available for public inspection within the county and/or service area in such a manner as will facilitate review of, and comments on, the plan; and
- cooperate with the State and/or County, to determine whether grantee performance goals, administrative standards, financial management requirements, and other requirements of the State

and County, in conducting monitoring reviews including (1) a full on-site review on an annual basis, (2) follow-up reviews if grantee fails to meet the goals, standards, and requirement established by the State, and (3) other reviews as appropriate, including reviews of grantee with other programs that have had other federal, State, or local grants terminated for cause; and

- make available appropriate books, documents, papers, and records for inspection, examination, copying, or mechanical reproduction on or off the premises upon reasonable request by the U.S. Controller General, the State, or their authorized representatives should an investigation of the uses of CSBG funds be undertaken; and
- in the case of county governments or grantees which receive a CSBG award in excess of \$100,000, comply with the following three certifications related to the "Limitation on use of appropriated funds to influence certain Federal Contracting and financial transactions (P.L. 101-121, Section 319 and USC Title 31 Section 1352)":
  1. No Federal appropriated funds have been paid or will be paid by or on behalf of the undersigned, to any person for influencing or attempting to influence an officer or employee of any agency, a Member of Congress, an officer or employee of Congress, or an employee of a Member of Congress in connection with the awarding of any Federal contract, continuation, renewal, amendment, or modification of any Federal contract, grant, loan, or cooperative agreement.
  2. If any funds other than Federal appropriated funds have been paid or will be paid to any person for influencing or attempting to influence an officer or employee of any agency, a Member of Congress, an officer or employee of Congress, or any employee of a Member of Congress in connection with this Federal contract, grant, loan, or cooperative agreement, the undersigned shall complete and submit Standard Form LLL, "Disclosure Form to Report Lobbying," in accordance with its instruction.
  3. The undersigned shall require that the language of this certification be included in the award document for subawards at all tiers (including subcontracts, subgrants, and contracts under grants, loans, and cooperative agreements) and that all subrecipients shall certify and disclose accordingly.

**The Grantee certifies to the best of its knowledge and belief, that it and its principals:**

- a) are not presently debarred, suspended, proposed for debarment, declared ineligible, or voluntarily excluded from covered transactions by any Federal department or agency;
- b) have not within a three-year period preceding this proposal been convicted or had a civil judgment rendered against them for commission of fraud or a criminal offense in connection with obtaining, attempting to obtain, or performing a public transaction; violation of Federal or State antitrust statutes or commission of embezzlement, theft, forgery, bribery, falsification or destruction of records, making false statements, or receiving stolen property;
- c) are not presently indicted for otherwise criminally or civilly charged by a governmental entity (Federal, State or local) with commission of any of the offenses enumerated in paragraph (b) of this certification; and
- d) have not within a three-year period preceding this application had one or more public transactions (Federal, State or local) terminated for cause or default.

**The Grantee further certifies that it:**

- a) requires that smoking not be permitted in any portion of any indoor routinely owned or leased or contracted for by an entity and used routinely or regularly for provisions of health, day care, education, or library services to children under the age of 18, if the services are funded by Federal programs either directly or through State or local governments, by Federal grant, contract, loan, or loan guarantee.
- b) that it will require the language of this certification be included in any sub awards which contain provisions for the children's services and that all Subgrantees shall certify accordingly.

*If you are unable to certify to any of the statements in this certification, please attach an explanation to this application.*

SIGNATURE: \_\_\_\_\_

PRINT NAME: \_\_\_\_\_

POSITION TITLE: \_\_\_\_\_

DATE: \_\_\_\_\_

**EXHIBIT 4**

**INSURANCE**

**General Liability Insurance:** Commercial General Liability Insurance written on ISO occurrence form CG 00 01 10/93 or equivalent, covering premises operations, fire damage, independent contractors, products and completed operations, blanket liability, personal injury, and advertising liability with minimum limits as follows:

General Aggregate	\$1,000,000
Each Occurrence	\$1,000,000
Products & Completed Operations Aggregate	\$1,000,000
Any One Fire	\$50,000

If any aggregate limit is reduced below \$1,000,000 because of claims made or paid, GRANTEE shall immediately obtain additional insurance to restore the full aggregate limit and furnish to Adams County a certificate or other document satisfactory to Adams County showing compliance with this provision.

**Automobile Liability Insurance:** To include all motor vehicles owned, hired, leased, or borrowed:

Bodily Injury/Property Damage	\$1,000,000 (each accident combined single limit)
Personal Injury Protection	per Colorado Statutes

**Worker's Compensation:** Worker's Compensation Insurance as required by State statute, and Employer's Liability insurance covering all of GRANTEE employees acting within the course and scope of their employment.



## PUBLIC HEARING AGENDA ITEM

<b>DATE OF PUBLIC HEARING: 02/23/2021</b>
<b>SUBJECT: Cost Amendment to Contract with Genesis Health Care, LLC for the Community Support Specialist</b>
<b>FROM: Katie Griego, Director</b>
<b>AGENCY/DEPARTMENT: Human Services Department</b>
<b>HEARD AT STUDY SESSION ON</b>
<b>AUTHORIZATION TO MOVE FORWARD: <input type="checkbox"/> YES <input type="checkbox"/> NO</b>
<b>RECOMMENDED ACTION:</b> That the Board of County Commissioners approves the cost amendment to the contract between the County of Adams, Colorado and Genesis Health Care, LLC for the Long-Term Care and Adult Medicaid processing Community Support Specialist.

### **BACKGROUND:**

Adams County Human Services Department contracts with various medical providers to process Adult Medicaid and Long-Term Care applications on behalf of their clients. Adams County hires Community Support Specialists (CSS) that can quickly process Adult Medicaid and Long-Term Care applications submitted by clients at these organizations.

Funding to pay for the salaries and benefits of the Adams County CSS who work on each of these contracts is as follows:

Genesis Health Care, LLC will fund thirteen percent (13%) of the salary and benefits for the Adams County CSS position. The remaining eighty seven percent (87%) will be reimbursed with federal Medicaid and State funds. The supervisory costs are included in the cost of the agreement.

Adams County Human Services Department's recommendation is to approve this contract to enable timely processing of Adult Medicaid and Long-Term Care applications. This contract will enhance the delivery of medical services to needy families in Adams County.

### **AGENCIES, DEPARTMENTS OR OTHER OFFICES INVOLVED:**

Adams County Human Services Department  
 Adams County Finance Department  
 Genesis Health Care, LLC

**ATTACHED DOCUMENTS:**

Resolution  
 Contract Cost Amendment between the Adams County Human Services Department and Genesis Health Care, LLC.

**FISCAL IMPACT:**

Please check if there is no fiscal impact . If there is fiscal impact, please fully complete the section below.

<b>Fund:</b> 15
<b>Cost Center:</b> 99915

	<b>Object Account</b>	<b>Subledger</b>	<b>Amount</b>
Current Budgeted Revenue:	99915.5755		50,239,790
Additional Revenue not included in Current Budget:			
<b>Total Revenues:</b>			<u>50,239,790</u>

Current Budgeted Operating Expenditure:	Various.7645		6,078,100
Add'l Operating Expenditure not included in Current Budget:			
Current Budgeted Capital Expenditure:			
Add'l Capital Expenditure not included in Current Budget:			
<b>Total Expenditures:</b>			<u><u>6,078,100</u></u>

New FTEs requested:  YES  NO

Future Amendment Needed:  YES  NO

**Additional Note: This is the 2020 Cost Amendment; the 2021 Cost Amendment will be sent through the Cost Amendment Contract process in the next 8-10 weeks.**

BOARD OF COUNTY COMMISSIONERS FOR  
ADAMS COUNTY, STATE OF COLORADO

RESOLUTION APPROVING CONTRACT COST AMENDMENT BETWEEN ADAMS  
COUNTY AND GENESIS HEALTH CARE, LLC FOR LONG TERM CARE AND ADULT  
MEDICAID APPLICATION PROCESSING SERVICES

WHEREAS, Genesis Health Care, LLC has requested to reimburse the Adams County Human Services Department (“ACHSD”) to employ one Community Support Specialist to process Adult Medicaid and Long-Term Care applications; and,

WHEREAS, current satellite Community Support Specialist deployments have resulted in reducing the typical Adult Medicaid and Long-Term Care application processing time frame from 45-60 days to 7-20 days, significantly improving client services, and facilitating cost savings; and,

WHEREAS, without a Community Support Specialist, Genesis Health Care, LLC would have to send application forms to the Human Services Center in Westminster, which would delay Adult Medicaid and Long-Term Care eligibility determination, provision of medical services to needy families, and timely payment for those services; and,

NOW, THEREFORE, BE IT RESOLVED, by the Board of County Commissioners, County of Adams, State of Colorado, that the contract cost amendment between Adams County and Genesis Health Care, LLC to provide a Community Support Specialist to process Adult Medicaid and Long-Term Care applications for the Genesis Health Care, LLC, a copy of which is attached hereto and incorporated herein by reference, be and hereby is approved.

BE IT FURTHER RESOLVED that the Chair of the Board of County Commissioners is authorized to execute said contract cost amendment and any program modifications and amendments on behalf of Adams County.





3/30/2020

**TO:** Lavette Eaddy  
 Genesis Health Care

**FROM:** DeeDee Green  
 Adams County Human Services Department

**DATE:** March 30, 2020

**RE:** Contract Cost Amendment

The purpose of this memo is to describe the change and increase of your financial responsibility. Effective January 1, 2020, there will be a change in the reimbursement for your Community Support Specialist (CSS). In 2014, the term of our contract was changed to automatic renewal with written notification of any modifications that are to be made.

The Adams County Finance Department completed a Medicaid contract analysis and determined that ninety percent (90%) of these costs can be charged to Medicaid and the State of Colorado, for Medicaid eligibility processing with the remaining ten percent (10%) chargeable to the contracting entity. For activities which are not related to eligibility processing, eighty percent (80%) of the costs can be charged to Medicaid and the State of Colorado with the remaining twenty percent (20%) chargeable to the contracting entity. The current average percentage that will be charged to the contracting entity was calculated at thirteen percent (13%).

The below table reflects your current and future financial responsibility while the waiver is in effect.

	<b>CURRENT</b>	<b>JAN 1, 2020</b>
Average Annual Employee Cost (including benefits and coverage)	\$6,033.14	\$9,862.27
Your Share of CSS Cost	\$603.31	\$821.86
Proportionate Supervisory, Coverage and Operational Costs	\$325.00	\$138.68
<b>Total Financial Responsibility</b>	<b>\$ 928.31</b>	<b>\$ 960.54</b>

Enclosed are two originals of the Contract Cost Amendment; please sign and return both originals to me. Once all parties have signed the amendment, a fully executed original will be returned to you. If you have any questions, please feel free to contact me at 720.523.2305.

IN WITNESS WHEREOF, the parties hereto have caused their names to be affixed hereto.

BOARD OF COUNTY COMMISSIONERS  
ADAMS COUNTY, COLORADO

\_\_\_\_\_  
Chair

\_\_\_\_\_  
Date

ATTEST:

APPROVED AS TO FORM:

\_\_\_\_\_  
CLERK AND RECORDER

\_\_\_\_\_  
Adams County Attorney's  
Office

\_\_\_\_\_  
Deputy Clerk

CONTRACTOR:

  
\_\_\_\_\_  
Name: Dana Runager  
Title: VP of Operations  
Genesis Health Care

Subscribed and sworn to before me this 23 day of OCTOBER 2020, by  
DANA RUNAGER.

  
\_\_\_\_\_  
Notary Public

My commission expires: 12/16/23

NICHOLAS JOSEPH CHIRA JR.  
NOTARY PUBLIC  
STATE OF COLORADO  
NOTARY ID 20194046638  
MY COMMISSION EXPIRES 12/16/2023



## PUBLIC HEARING AGENDA ITEM

<b>DATE OF PUBLIC HEARING:</b> February 23, 2021
<b>SUBJECT:</b> Resolution accepting Warranty Deed conveying property from Ogden North Enterprises, LLC, to Adams County, for the dedication of road right-of-way
<b>FROM:</b> Kristin Sullivan, AICP, Director of Public Works Brian Staley, P.E., PTOE, Deputy Director of Public Works
<b>AGENCY/DEPARTMENT:</b> Public Works
<b>HEARD AT STUDY SESSION ON:</b> N/A
<b>AUTHORIZATION TO MOVE FORWARD:</b> <input type="checkbox"/> YES <input type="checkbox"/> NO
<b>RECOMMENDED ACTION:</b> That the Board of County Commissioners accepts the Warranty Deed for the acquisition of property needed for road right-of-way.

### **BACKGROUND:**

Adams County is in the process of acquiring right-of-way along East 58th Avenue for the East 58th Avenue Improvements Project – East 58th Avenue from Clarkson Street to York Street. The County is in need of a portion of Ogden North Enterprises, LLC, property for the construction of curb, gutter, sidewalk and drainage improvements. The attached resolution allows Adams County to accept the Warranty Deed.

### **AGENCIES, DEPARTMENTS OR OTHER OFFICES INVOLVED:**

Adams County Public Works, Office of the County Attorney and Adams County Board of County Commissioners.

### **ATTACHED DOCUMENTS:**

Draft resolution  
Warranty Deed  
Planning Commission resolution

**FISCAL IMPACT:**

Please check if there is no fiscal impact . If there is fiscal impact, please fully complete the section below.

<b>Fund:</b>
<b>Cost Center:</b>

	<b>Object Account</b>	<b>Subledger</b>	<b>Amount</b>
Current Budgeted Revenue:			
Additional Revenue not included in Current Budget:			
<b>Total Revenues:</b>			<hr/>

	<b>Object Account</b>	<b>Subledger</b>	<b>Amount</b>
Current Budgeted Operating Expenditure:			
Add'l Operating Expenditure not included in Current Budget:			
Current Budgeted Capital Expenditure:			
Add'l Capital Expenditure not included in Current Budget:			
<b>Total Expenditures:</b>			<hr/>

**New FTEs requested:**             YES             NO

**Future Amendment Needed:**     YES             NO

**Additional Note:**

BOARD OF COUNTY COMMISSIONERS FOR  
ADAMS COUNTY, STATE OF COLORADO

RESOLUTION ACCEPTING WARRANTY DEED CONVEYING PROPERTY FROM  
OGDEN NORTH ENTERPRISES, LLC, TO ADAMS COUNTY FOR THE DEDICATION OF  
ROAD RIGHT-OF-WAY

WHEREAS, Adams County is in the process of acquiring right-of-way and temporary construction easements along East 58<sup>th</sup> Avenue for the East 58<sup>th</sup> Avenue Improvements Project – East 58<sup>th</sup> Avenue from Clarkson Street to York Street (the “Project”); and,

WHEREAS, this right-of-way parcel is from property at 955 East 58<sup>th</sup> Avenue, located in the Southwest Quarter of Section 11, Township 3 South, Range 68 West of the 6<sup>th</sup> Principal Meridian, County of Adams, State of Colorado, and owned by Ogden North Enterprises, LLC, (“Parcel 4”); and,

WHEREAS, Adams County requires ownership of Parcel 4 for construction of the Project; and,

WHEREAS, Ogden North Enterprises, LLC, has executed a Warranty Deed to dedicate Parcel 4 for road right-of-way purposes for East 58<sup>th</sup> Avenue that complies with County standards and will benefit the citizens of Adams County; and,

WHEREAS, at a regular meeting of the Planning Commission for Adams County, Colorado, held at the County Government Center in Brighton on Thursday the 12<sup>th</sup> day of November, 2020, the Planning Commission recommended that the Board of County Commissioners accept said Warranty Deed.

NOW, THEREFORE, BE IT RESOLVED, by the Board of County Commissioners, County of Adams, State of Colorado, that the Warranty Deed from Ogden North Enterprises, LLC, a copy of which is attached hereto and incorporated herein by this reference, be and hereby is accepted.

BE IT FURTHER RESOLVED, that the Chair of the Board of County Commissioners is hereby authorized to accept said Warranty Deed and execute any attending documents on behalf of Adams County.

Doc Fee: \$0 - Tax Exempt

**WARRANTY DEED**

**THIS DEED**, dated this 2<sup>nd</sup> day of July, 2020, between **OGDEN NORTH ENTERPRISES, LLC, a Colorado limited liability company**, whose address is PO Box 2, Brighton Colorado, 80601, grantor(s), and the **COUNTY OF ADAMS, State of Colorado**, whose legal address is 4430 South Adams County Parkway, Brighton, Colorado 80601 of the said County of Adams and State of Colorado, grantee(s):

**WITNESS**, that the grantor(s), for and in consideration of the sum of \$10,400.00, and other good and valuable consideration, the receipt and sufficiency of which is hereby acknowledged, have granted, bargained, sold and conveyed, and by these presents doth grant, bargain, sell, convey and confirm, unto the grantee(s), its successors and assigns forever, all the real property, together with improvements, if any, situate, lying and being in the said County of Adams, State of Colorado, described as follows:

Legal description as set forth in Exhibit "A" attached hereto and incorporated herein by this reference.

Also known by street and number as: being a portion of 955 East 58<sup>th</sup> Avenue  
Assessor's schedule or parcel number: 0182511300087

**TOGETHER** with all and singular the hereditaments and appurtenances thereto belonging, or in anywise appertaining, the reversion and reversions, remainder and remainders, rents, issues and profits thereof, and all the estate, right, title, interest, claim and demand whatsoever of the grantor(s), either in law or equity, of, in and to the above bargained premises, with the hereditaments and appurtenances;

**TO HAVE AND TO HOLD** the said premises above bargained and described, with the appurtenances, unto the grantee(s), its successors and assigns forever. The grantor(s), for itself, its successors and assigns, do covenant, grant, bargain and agree to and with the grantee(s), its successors and assigns, that at the time of the ensembling and delivery of these presents, it is well seized of the premises above conveyed, have good, sure, perfect, absolute and indefeasible estate of inheritance, in law, in fee simple, and have good right, full power and authority to grant, bargain, sell and convey the same in manner and form as aforesaid, and that the same are free and clear from all former and other grants, bargains, sales, liens, taxes, assessments, encumbrances and restrictions of whatever kind or nature whatsoever, except interests of record as set forth on Exhibit B attached hereto.

The grantor(s) shall and will **WARRANT AND FOREVER DEFEND** the above bargained premises in the quiet and peaceable possession of the grantee(s), its successors and assigns, against all and every person or persons lawfully claiming the whole or any part thereof, excepting interests of record as set forth on Exhibit B attached hereto.

**IN WITNESS WHEREOF**, the grantor(s) have executed this deed on the date set forth above.

MITCHELL GLENN HAUFF  
Notary Public  
State of Colorado  
Notary ID # 20144016002  
My Commission Expires 04-16-2022

Ogden North Enterprises, LLC, a Colorado limited liability company

By: Larry J. Weiman

Print: LARRY J. WEIMAN

Title: MANAGER

STATE OF Colorado )  
County of Adams ) §

The foregoing instrument was acknowledged before me this 2<sup>nd</sup> day of July, 2020, by Larry J. Weiman, as MANAGER of Ogden North Enterprises, LLC, a Colorado limited liability company.

Witness my hand and official seal.  
My commission expires: April 16, 2022

Mitchell Hauff  
Notary Public

70678052





Drexel, Barrell & Co.

JULY 12, 2019

EXHIBIT A  
LEGAL DESCRIPTION  
PARCEL RW-4  
RIGHT-OF-WAY DEDICATION

Engineers/Surveyors

Boulder  
Colorado Springs  
Greeley

1800 38<sup>th</sup> Street  
Boulder, CO 80301-2620

303.442.4338  
303.442.4373 Fax

A TRACT OF LAND BEING A PORTION OF THAT TRACT OF LAND DESCRIBED AT RECEPTION NO. B319878 IN THE ADAMS COUNTY RECORDS, LOCATED IN THE SW1/4 OF SECTION 11, T3S, R68W OF THE 6TH P.M., COUNTY OF ADAMS, STATE OF COLORADO, BEING MORE PARTICULARLY DESCRIBED AS FOLLOWS:

**BEGINNING** AT THE SOUTHEAST CORNER OF SAID TRACT OF LAND DESCRIBED AT RECEPTION NO. B319878, SAID POINT BEING ON THE NORTHERLY LINE OF EAST 58TH AVENUE; THENCE N89°54'29"W, 40.00 FEET ALONG THE SOUTHERLY LINE OF SAID TRACT OF LAND AND ALONG SAID NORTHERLY LINE OF EAST 58TH AVENUE; THENCE N00°05'31"E, 20.00 FEET; THENCE S89°54'29"E, 40.00 FEET TO THE EASTERLY LINE OF SAID TRACT OF LAND; THENCE S00°05'31"W, 20.00 FEET ALONG THE EASTERLY LINE OF SAID TRACT OF LAND TO THE **POINT OF BEGINNING**.

CONTAINING 0.018 ACRES OR 800 SQUARE FEET, MORE OR LESS.

LEGAL DESCRIPTION PREPARED BY:  
MATHEW E. SELDERS  
DREXEL, BARRELL & CO.  
1800 38TH STREET  
BOULDER, CO 80301  
(303) 442-4338



**EXHIBIT**  
**PARCEL RW-4**  
**R.O.W. DEDICATION**

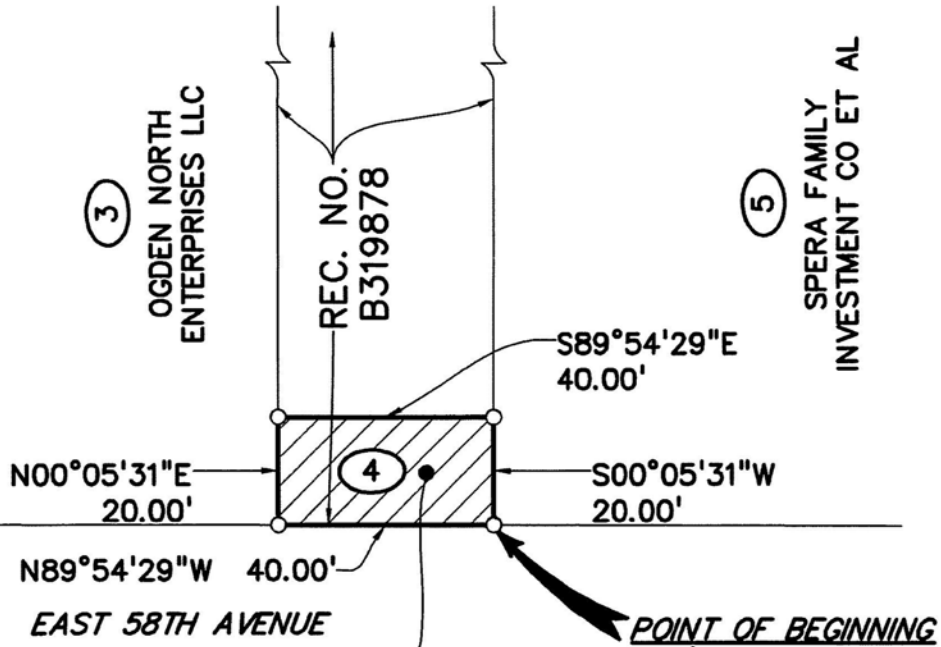

OGDEN NORTH ENTERPRISES LLC  
 955 E 58TH AVE  
 AREA = 800 SQ.FT. +/-,  
 0.018 ACRES +/-



SCALE 1" = 30'

**NOTES**

1. THIS MAP IS NOT A LAND SURVEY PLAT OR AN IMPROVEMENT SURVEY PLAT. IT IS INTENDED ONLY TO DEPICT THE ATTACHED DESCRIPTION
2. INFORMATION PERTAINING TO OWNERSHIP & RIGHT-OF-WAY IS BASED UPON PUBLIC INFORMATION AVAILABLE FROM THE ADAMS COUNTY ASSESSORS OFFICE, AND DOES NOT CONSTITUTE A TITLE SEARCH BY DREXEL, BARRELL & CO. TO DETERMINE OWNERSHIP & EASEMENTS OF RECORD.

IN ACCORDANCE WITH CRS 13-80-105;  
 NOTICE: ACCORDING TO COLORADO LAW YOU MUST COMMENCE ANY LEGAL ACTION BASED UPON ANY DEFECT IN THIS SURVEY WITHIN THREE YEARS AFTER YOU FIRST DISCOVER SUCH DEFECT. IN NO EVENT, MAY ANY ACTION BASED UPON ANY DEFECT IN THIS SURVEY BE COMMENCED MORE THAN TEN YEARS FROM THE DATE OF THE CERTIFICATION SHOWN HEREON.

**Drexel, Barrell & Co.** Engineers/Surveyors  
 1800 38TH STREET BOULDER, COLORADO 80301 (303) 442-4336  
 BOULDER, COLORADO (303) 442-4338  
 COLORADO SPRINGS, COLORADO (719) 280-0887  
 GREELEY, COLORADO (970) 351-0846

Revisions - Date	Date	Drawn By	Job No.
	8/15/19	MMF	20961-00
	Scale	Checked By	Drawing No.
	1"=30'	MES	IN FILE

H:\20961-00\BTR\SURVEY\Drawings\RW-4.dwg, 8/15/2019 12:05:54 PM



## EXHIBIT B

**4. The following documents affect the land:**

- 1) EXISTING LEASES AND TENANCIES, IF ANY.
- 2) LEASE BETWEEN OGDEN NORTH ENTERPRISES, LESSOR, AND VARIOUS LESSEES, AS SHOWN BY MEMORANDUM OF LEASE RECORDED JUNE 11, 1981, UNDER RECEPTION NOS.

## EXHIBIT B

B328097, B328098, B328099, B328100, B328101, B328102, B328103 AND B328104.

ASSIGNMENT OF LEASE RECORDED APRIL 22, 1985 UNDER RECEPTION NO. B568808.

3) TERMS, CONDITIONS, PROVISIONS, BURDENS, OBLIGATIONS AND EASEMENTS AS SET FORTH AND GRANTED IN UTILITY EASEMENT RECORDED AUGUST 23, 1935 IN BOOK 225 AT PAGE 513.

4) TERMS, CONDITIONS, PROVISIONS, BURDENS, OBLIGATIONS AND EASEMENTS AS SET FORTH AND GRANTED IN UTILITY EASEMENT RECORDED NOVEMBER 25, 1953 IN BOOK 481 AT PAGE 98.

5) TERMS, CONDITIONS, PROVISIONS, BURDENS, OBLIGATIONS AND EASEMENTS AS SET FORTH AND GRANTED IN EASEMENT DEED RECORDED APRIL 13, 1955 IN BOOK 544 AT PAGE 254.

6) EASEMENT AND RIGHTS OF OTHERS TO USE THAT PORTION OF OGDEN STREET CROSSING SUBJECT PROPERTY, SAID OGDEN STREET WAS VACATED IN VACATION OF RIGHT-OF-WAY RECORDED NOVEMBER 3, 1965 IN BOOK 1257 AT PAGE 93.

7) THE EFFECT OF LICENSE AGREEMENT RECORDED JULY 07, 1970, IN BOOK 1611 AT PAGE 34.

NORTH WASHINGTON STREET AND SANITATION DISTRICT WATER AND SEWER UTILITIES BASE MAP - INDEX RECORDED MAY 8, 2017 UNDER RECEPTION NO. 2017000039965.

NOTE: THIS BINDER IS NOT A REPORT OR REPRESENTATION AS TO MINERAL INTERESTS, AND SHOULD NOT BE USED, OR RELIED UPON, IN CONNECTION WITH THE NOTICE REQUIREMENTS THAT ARE SET FORTH IN CRS 24-65.5-103.

NOTE: THIS BINDER DOES NOT REFLECT THE STATUS OF TITLE TO WATER RIGHTS OR REPRESENTATION OF SAID RIGHTS, RECORDED OR NOT.

NOTE: ADDITIONAL UPDATES TO THE EFFECTIVE DATE OF THE BINDER MAY BE REQUESTED BY THE PROPOSED INSURED. ONE UPDATE IS INCLUDED WITH THIS BINDER AT NO ADDITIONAL COST. ANY ADDITIONAL UPDATES WILL BE ISSUED AT THE COST OF \$125 PER UPDATE. FOR EACH UPDATE PROVIDED, A REVISED BINDER WILL BE ISSUED SHOWING A NEW EFFECTIVE DATE AND ANY MATTERS RECORDED SINCE THE EFFECTIVE DATE OF THE PREVIOUS BINDER.

AGENDA ITEM

PLANNING COMMISSION FOR  
ADAMS COUNTY, STATE OF COLORADO

RESOLUTION RECOMMENDING ACCEPTANCE OF A WARRANTY DEED  
FROM THE OGDEN NORTH ENTERPRISES, LLC, TO ADAMS COUNTY  
FOR RIGHT-OF-WAY PURPOSES

At the regular meeting for the Planning Commission for Adams County, Colorado, held at County Government Center in Brighton on Thursday the 12th day of November, 2020, the following proceedings and others were had and done, to wit:

WHEREAS, the Adams County Planning Commission has considered the advisability of acceptance by the Board of County Commissioners of a Warranty Deed from Ogden North Enterprises, LLC, for right-of-way purposes on the following described land to wit:

Legal description as set forth in Exhibit "A" attached hereto and incorporated herein by this reference.

WHEREAS, this Warranty Deed is in conjunction with the East 58th Avenue for the East 58th Avenue Improvements Project – East 58th Avenue from Clarkson Street to York Street, and is a portion of 955 East 58<sup>th</sup> Avenue located in the Southwest Quarter of Section 11, Township 3 South, Range 68 West of the 6<sup>th</sup> Principal Meridian, County of Adams, State of Colorado.

NOW, THEREFORE, BE IT RESOLVED, that the Adams County Planning Commission recommends to the Board of County Commissioners that said Warranty Deed from Ogden North Enterprises, LLC, be accepted by the Board of County Commissioners.

Upon a motion duly made and seconded, the foregoing resolution was adopted.

I, Justin Martinez, Chairperson/Acting Chairperson of the Adams County Planning Commission do hereby certify that the annexed foregoing resolution is a true and correct record of the proceedings of the Adams County Planning Commission.

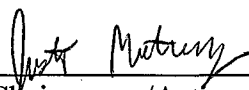
  
\_\_\_\_\_  
Chairperson/Acting Chairperson  
Adams County Planning Commission



## PUBLIC HEARING AGENDA ITEM

<b>DATE OF PUBLIC HEARING:</b> February 23, 2021
<b>SUBJECT:</b> Abatements
<b>FROM:</b> Douglas Edelstein, Deputy Adams County Attorney
<b>AGENCY/DEPARTMENT:</b> County Attorney
<b>HEARD AT STUDY SESSION ON:</b> N/A
<b>AUTHORIZATION TO MOVE FORWARD:</b> <input checked="" type="checkbox"/> YES <input type="checkbox"/> NO
<b>RECOMMENDED ACTION:</b> That the Board of County Commissioners approves the recommendations of the Assessor's Office for the attached abatement petitions.

### **BACKGROUND:**

The Assessor's Office reviewed the attached abatement petitions concerning tax years 2018 and 2020 and has agreed to the abated values for the respective accounts. The findings and recommendations of the Assessor's Office are attached hereto for approval and adoption.

### **AGENCIES, DEPARTMENTS OR OTHER OFFICES INVOLVED:**

Adams County Assessor's Office

### **ATTACHED DOCUMENTS:**

Resolution  
Summary Findings and Recommendations of the Assessor's Office

**FISCAL IMPACT:**

Please check if there is no fiscal impact . If there is fiscal impact, please fully complete the section below.

<b>Fund:</b>
<b>Cost Center:</b>

	<b>Object Account</b>	<b>Subledger</b>	<b>Amount</b>
Current Budgeted Revenue:			
Additional Revenue not included in Current Budget:			
<b>Total Revenues:</b>			<hr/>

	<b>Object Account</b>	<b>Subledger</b>	<b>Amount</b>
Current Budgeted Operating Expenditure:			
Add'l Operating Expenditure not included in Current Budget:			
Current Budgeted Capital Expenditure:			
Add'l Capital Expenditure not included in Current Budget:			
<b>Total Expenditures:</b>			<hr/>

New FTEs requested:             YES             NO

Future Amendment Needed:     YES             NO

**Additional Note:**

RESOLUTION APPROVING ABATEMENT PETITIONS AND AUTHORIZING THE  
REFUND OF TAXES FOR ACCOUNT NUMBERS P0038270, R0197628, R0083906,  
R0179912, R0182140 and R0180881

WHEREAS, pursuant to C.R.S. § 39-1-113, the Board of County Commissioners may approve abatement petitions concerning property tax assessment and may refund taxes associated therewith; and,

WHEREAS, the attached petitions for account numbers P0038270, R0197628, R0083906, R0179912, R0182140 and R0180881 have been processed, reviewed and approved by the Adams County Assessor's Office; and,

WHEREAS, information regarding the initial assessed value and the justification for reduction in assessed value and refund of taxes is included for each property in the documentation attached; and,

WHEREAS, it is the recommendation of the Assessor's Office that these petitions be approved and refunds be issued by the Board of County Commissioners; and,

WHEREAS, for account number R0180881, approval by the Board of County Commissioners shall be forwarded as a recommendation to the Colorado Property Tax Administrator for review and approval as required by C.R.S. §§ 39-1-113(3) and 39-2-116.

NOW, THEREFORE, BE IT RESOLVED, by the Board of County Commissioners, County of Adams, State of Colorado, that the abatement petitions for account numbers P0038270, R0197628, R0083906, R0179912 and R0182140 are hereby approved.

BE IT FURTHER RESOLVED, by the Board of County Commissioners, County of Adams, State of Colorado, that the resolution approving the petition for account number R0180881 be forwarded, for review, to the Colorado Property Tax Administrator to approve the abatement petition for the Property.



**FOR ASSESSORS AND COUNTY COMMISSIONERS USE ONLY**

(Section III or Section IV must be completed)

Every petition for abatement or refund filed pursuant to § 39-10-114, C.R.S. shall be acted upon pursuant to the provisions of this section by the Board of County Commissioners or the Assessor, as appropriate, within six months of the date of filing such petition, § 39-1-113(1.7), C.R.S.

**Section III: Written Mutual Agreement of Assessor and Petitioner**

(Only for abatements up to \$10,000)

The Commissioners of \_\_\_\_\_ County authorize the Assessor by Resolution No. \_\_\_\_\_ to review petitions for abatement or refund and to settle by written mutual agreement any such petition for abatement or refund in an amount of \$10,000 or less per tract, parcel, or lot of land or per schedule of personal property, in accordance with § 39-1-113(1.5), C.R.S.

**The Assessor and Petitioner mutually agree to the values and tax abatement/refund of:**

	Tax Year _____		
	<u>Actual</u>	<u>Assessed</u>	<u>Tax</u>
Original	_____	_____	_____
Corrected	_____	_____	_____
Abate/Refund	_____	_____	_____

Note: The total tax amount does not include accrued interest, penalties, and fees associated with late and/or delinquent tax payments, if applicable. Please contact the County Treasurer for full payment information.

Petitioner's Signature \_\_\_\_\_ Date \_\_\_\_\_

Assessor's or Deputy Assessor's Signature \_\_\_\_\_ Date \_\_\_\_\_

**Section IV: Decision of the County Commissioners**

(Must be completed if Section III does not apply)

WHEREAS, the County Commissioners of \_\_\_\_\_ County, State of Colorado, at a duly and lawfully called regular meeting held on \_\_\_\_/\_\_\_\_/\_\_\_\_, at which meeting there were present the following members:

Month Day Year

with notice of such meeting and an opportunity to be present having been given to the Petitioner and the Assessor of said County and Assessor \_\_\_\_\_ (*being present--not present*) and

Name

Petitioner \_\_\_\_\_ (*being present--not present*), and WHEREAS, the said

Name

County Commissioners have carefully considered the within petition, and are fully advised in relation thereto, NOW BE IT RESOLVED that the Board (*agrees--does not agree*) with the recommendation of the Assessor, and that the petition be (*approved--approved in part--denied*) with an abatement/refund as follows:

Year	Assessed Value	Taxes Abate/Refund
_____	_____	_____

\_\_\_\_\_  
Chairperson of the Board of County Commissioners' Signature

I, \_\_\_\_\_ County Clerk and Ex-Officio Clerk of the Board of County Commissioners in and for the aforementioned county, do hereby certify that the above and foregoing order is truly copied from the record of the proceedings of the Board of County Commissioners.

**IN WITNESS WHEREOF**, I have hereunto set my hand and affixed the seal of said County

this \_\_\_\_\_ day of \_\_\_\_\_, \_\_\_\_\_  
Month Year

\_\_\_\_\_  
County Clerk's or Deputy County Clerk's Signature

Note: Abatements greater than \$10,000 per schedule, per year, must be submitted in duplicate to the Property Tax Administrator for review.

**Section V: Action of the Property Tax Administrator**

(For all abatements greater than \$10,000)

The action of the Board of County Commissioners, relative to this petition, is hereby

Approved  Approved in part \$ \_\_\_\_\_  Denied for the following reason(s):

Secretary's Signature \_\_\_\_\_ Property Tax Administrator's Signature \_\_\_\_\_ Date \_\_\_\_\_



<b>ABATEMENT FOR TAX YEAR:</b>		<b>2020</b>			
<b>TODAYS DATE</b>		<b>01/29/21</b>			
<b>BUSINESS NAME:</b>		<b>Brighton Crossing Residential LLC</b>			
<b>ACCOUNT NUMBER:</b>		<b>P0038270</b>			
<b>PARCEL NUMBER:</b>					
		<b>ACTUAL</b>	<b>ASSESSED</b>	<b>MILL</b>	<b>TAX</b>
		<b>VALUE</b>	<b>VALUE</b>	<b>LEVY</b>	<b>DOLLARS</b>
<b>ORIGINAL VALUE</b>		<b>\$53,430</b>	<b>\$15,490</b>	<b>160.332</b>	<b>\$2,483.54</b>
<b>REVISED VALUE</b>		<b>\$0</b>	<b>\$0</b>	<b>160.332</b>	<b>\$0.00</b>
<b>ABATED VALUE</b>		<b>\$53,430</b>	<b>\$15,490</b>	<b>160.332</b>	<b>\$2,483.54</b>

**Provide your reason for the Abatement/Added in the space below:**

Assessor Error two accounts were created for the same property.

**ADDED ASSESSMENT FOR TAX YEAR:**

<b>BUSINESS NAME:</b>					
<b>ACCOUNT NUMBER:</b>					
<b>PARCEL NUMBER:</b>					
		<b>ACTUAL</b>	<b>ASSESSED</b>	<b>MILL</b>	<b>TAX</b>
		<b>VALUE</b>	<b>VALUE</b>	<b>LEVY</b>	<b>DOLLARS</b>
<b>ORIGINAL VALUE</b>			<b>\$0</b>		<b>\$0.00</b>
<b>REVISED VALUE</b>			<b>\$0</b>	<b>0</b>	<b>\$0.00</b>
<b>ADDED VALUE</b>		<b>\$0</b>	<b>\$0</b>	<b>0</b>	<b>\$0.00</b>

PETITION FOR ABATEMENT OR REFUND OF TAXES

County: ADAMS

Date Received (Use Assessor's or Commissioners' Date Stamp)

Section I: Petitioner, please complete Section I only.

Date: 1/26/2021 (Month Day Year)

Petitioner's Name: Adams County Assessor on behalf of the Property owner Herrmann Alexander

Petitioner's Mailing Address:

City or Town State Zip Code

Table with 2 columns: SCHEDULE OR PARCEL NUMBER(S) and PROPERTY ADDRESS OR LEGAL DESCRIPTION OF PROPERTY. Row 1: R0197628, 6746 CLAY ST

Petitioner requests an abatement or refund of the appropriate taxes and states that the taxes assessed against the above property for the property tax year 2020 are incorrect for the following reasons: (Briefly describe why the taxes have been levied erroneously or illegally, whether due to erroneous valuation, irregularity in levying, clerical error, or overvaluation. Attach additional sheets if necessary.)

Assessor error. The ratio percentage is incorrect should be 7.15% not 29%.

Petitioner's estimate of value: \$ 430,054 (2020) Value Year

I declare, under penalty of perjury in the second degree, that this petition, together with any accompanying exhibits or statements, has been prepared or examined by me, and to the best of my knowledge, information, and belief, is true, correct, and complete.

Signature of Petitioner (Jan Heary) and Agent's Signature

Daytime Phone Number (720) 523-6743, Email, Daytime Phone Number, Email

\*Letter of agency must be attached when petition is submitted by an agent.

If the Board of County Commissioners, pursuant to § 39-10-114(1), C.R.S., or the Property Tax Administrator, pursuant to § 39-2-116, C.R.S., denies the petition for refund or abatement of taxes in whole or in part, the Petitioner may appeal to the Board of Assessment Appeals pursuant to the provisions of § 39-2-125, C.R.S., within thirty days of the entry of any such decision, § 39-10-114.5(1), C.R.S.

Section II: Assessor's Recommendation (For Assessor's Use Only). Includes table for Actual, Assessed, Tax and checkboxes for approval or denial.

**FOR ASSESSORS AND COUNTY COMMISSIONERS USE ONLY**

(Section III or Section IV must be completed)

Every petition for abatement or refund filed pursuant to § 39-10-114, C.R.S. shall be acted upon pursuant to the provisions of this section by the Board of County Commissioners or the Assessor, as appropriate, within six months of the date of filing such petition, § 39-1-113(1.7), C.R.S.

**Section III: Written Mutual Agreement of Assessor and Petitioner**  
(Only for abatements up to \$10,000)

The Commissioners of \_\_\_\_\_ County authorize the Assessor by Resolution No. \_\_\_\_\_ to review petitions for abatement or refund and to settle by written mutual agreement any such petition for abatement or refund in an amount of \$10,000 or less per tract, parcel, or lot of land or per schedule of personal property, in accordance with § 39-1-113(1.5), C.R.S.

The Assessor and Petitioner mutually agree to the values and tax abatement/refund of:

	Tax Year _____		
	<u>Actual</u>	<u>Assessed</u>	<u>Tax</u>
Original	_____	_____	_____
Corrected	_____	_____	_____
Abate/Refund	_____	_____	_____

Note: The total tax amount does not include accrued interest, penalties, and fees associated with late and/or delinquent tax payments, if applicable. Please contact the County Treasurer for full payment information.

\_\_\_\_\_  
Petitioner's Signature Date

\_\_\_\_\_  
Assessor's or Deputy Assessor's Signature Date

**Section IV: Decision of the County Commissioners**  
(Must be completed if Section III does not apply)

WHEREAS, the County Commissioners of \_\_\_\_\_ County, State of Colorado, at a duly and lawfully called regular meeting held on \_\_\_\_/\_\_\_\_/\_\_\_\_, at which meeting there were present the following members:

Month Day Year

with notice of such meeting and an opportunity to be present having been given to the Petitioner and the Assessor of said County and Assessor \_\_\_\_\_ (being present--not present) and  
Petitioner \_\_\_\_\_ (being present--not present), and WHEREAS, the said  
County Commissioners have carefully considered the within petition, and are fully advised in relation thereto,  
NOW BE IT RESOLVED that the Board (agrees--does not agree) with the recommendation of the Assessor,  
and that the petition be (approved--approved in part--denied) with an abatement/refund as follows:

Year	Assessed Value	Taxes Abate/Refund

\_\_\_\_\_  
Chairperson of the Board of County Commissioners' Signature

I, \_\_\_\_\_ County Clerk and Ex-Officio Clerk of the Board of County Commissioners in and for the aforementioned county, do hereby certify that the above and foregoing order is truly copied from the record of the proceedings of the Board of County Commissioners.

IN WITNESS WHEREOF, I have hereunto set my hand and affixed the seal of said County  
this \_\_\_\_\_ day of \_\_\_\_\_  
Month Year

\_\_\_\_\_  
County Clerk's or Deputy County Clerk's Signature

Note: Abatements greater than \$10,000 per schedule, per year, must be submitted in duplicate to the Property Tax Administrator for review.

**Section V: Action of the Property Tax Administrator**  
(For all abatements greater than \$10,000)

The action of the Board of County Commissioners, relative to this petition, is hereby

Approved  Approved in part \$ \_\_\_\_\_  Denied for the following reason(s):

\_\_\_\_\_  
Secretary's Signature Property Tax Administrator's Signature Date

**ASSESSOR'S RECOMMENDATION  
BOARD OF COUNTY COMMISSIONERS**

Account No : R0197628 Parcel No : 01825-05-1-20-018  
 Petition Year : 2020 Date Filed : January 26, 2021  
 Owner Entity : HERRMANN ALEXANDER S AND SCHERLIN TREVOR B  
 Owner Address : 6746 Clay St  
 Owner City : Denver State : CO, 80221  
 Property Location : POMPONIO TERRACE FLG 1 PLAT CORRECTION NO 1 BLK 4 LOT 5

TYPE	OCC CODE	PETITIONER'S REQUESTED VALUES		ASSESSOR'S ASSIGNED VALUES		ORIGINAL TAX WARRANT	
		Actual Value	Assessed Value	Actual Value	Assessed Value		
REAL	100	L: \$65,983	\$4,718	L: \$65,983	\$19,140	A. Ratio	7.15%
		I: \$364,071	\$26,031	I: \$364,071	\$26,030	Mill Levy	176.680
<b>TOTALS :</b>		<b>\$430,054</b>	<b>\$30,749</b>	<b>\$430,054</b>	<b>\$45,170</b>	Original Tax	<b>\$7,980.64</b>

**Tax Exempt Portion**  
0%

**Petitioner's Statement:**

Taxes are not calculated correctly.

**Assessor's Report**

**Situation :**

Reviewed the account. The 2020 taxes were showing \$7,980.64 payable in 2021. However, when calculating the taxes by hand the taxes should have been \$5,432.71. The value is not being protested just the calculation. Land was assessed at 29% should have been 7.15%.  $430,054 \times 7.15\% \times 0.176680 = 5,432.71$ .

**Action :**

The taxpayer called in regards to the taxes being significantly higher than the properties on each side of him. In review the property was shoing as vacant but had the improvements on as well. The vacant land was valued at Market PW instead of Market. This has been fixed in RealWare.

**Recommendation :**

Upon further review, a reduction in value appears warranted.

**ASSESSOR'S RECOMMENDED ADJUSTMENT**

TYPE	OCC CODE	ASSESSOR'S ASSIGNED VALUE		RECOMMENDED VALUE		REVISED TAX WARRANT
		Actual Value	Assessed Value	Actual Value	Assessed Value	Tax Refund
REAL	100	L: \$65,983	\$19,140	L: \$65,983	\$4,720	\$2,547.73
		I: \$364,071	\$26,030	I: \$364,071	\$26,030	Revised Tax
<b>TOTALS :</b>		<b>\$430,054</b>	<b>\$45,170</b>	<b>\$430,054</b>	<b>\$30,750</b>	<b>\$5,432.91</b>

*Eric I Norberg*

January 27, 2021

Eric I Norberg  
 Residential Appraiser III, Adams County Assessor's Office  
 Colorado Licensed Appraiser AL01323002

Date

**Ken Musso**  
Assessor



Assessor's Office  
4430 South Adams County Parkway  
2nd Floor, Suite C2100  
Brighton, CO 80601-8201  
Phone 720-523-6038  
Fax 720-523-6037  
www.adcogov.org

**BOARD OF COUNTY COMMISSIONERS**

**STIPULATION (As to Tax Year(s) 2020 Actual Value(s))**

1. The property subject to this Stipulation is:  
Schedule No. (S): R0083906 Parcel NO.(S) 0182100007001
  
2. The subject property is classified as a Vacant Land property.
  
3. The County Assessor originally assigned the following actual value to the subject property for tax year(s) 2020 :  
  
Land \$924,877
  
4. The Adams County Assessor has reviewed this file and agrees to make the following adjustment to the valuation for the subject property for tax year(s) 2020 :  
  
Land \$682,980
  
5. By entering into this agreement, the Petitioner understands that they are giving up rights to further appeal of the value of this property for tax year(s) 2020.

DATED this: February 4th, 2021

Michelle Taxbell  
Petitioner's Representative

Ryan, LLC  
1999 Broadway, suite 4100  
Denver, CO 80202

Stacy Phillips  
Assessor Representative  
Adams County Assessor's Office

**ASSESSOR'S RECOMMENDATION COUNTY BOARD OF EQUALIZATION**

Account No : R0083906 Parcel No : 0182100007001  
 Petition Year : 2020 Date Filed : January 13, 2021  
 Owner Entity : 40th Chambers, LLC / C/O Atrium Hospitality  
 Owner Address : 12735 Morris Road Ext STE. 400  
 Owner City : Alpharetta State : GA

Property Location :

TYPE	OCC CODE	PETITIONER'S REQUESTED VALUES		ASSESSOR'S ASSIGNED VALUES		ORIGINAL TAX WARRANT
		Actual Value	Assessed Value	Actual Value	Assessed Value	
REAL		L: \$682,762	\$198,000	L: \$924,877	\$268,210	A. Ratio 29.00%
		I: \$0	\$0	I: \$0	\$0	Mill Levy 117.794
<b>TOTALS :</b>		<b>\$682,762</b>	<b>\$198,000</b>	<b>\$924,877</b>	<b>\$268,210</b>	Original Tax <b>\$31,594</b>

**Tax Exempt Portion**  
0%

**Petitioner's Statement :**

**Assessor's Report**

**Situation :**

This account came off of present worth discounting to a value higher than market value.

**Action :**

Decreased the value to what the market value is indicating.

**Recommendation :**

Upon further review, a reduction in value appears warranted.

**ASSESSOR'S RECOMMENDED ADJUSTMENT**

TYPE	OCC CODE	ASSESSOR'S ASSIGNED VALUE		RECOMMENDED VALUE		REVISED TAX WARRANT
		Actual Value	Assessed Value	Actual Value	Assessed Value	Tax Refund
REAL		L: \$924,877	\$268,210	L: \$682,980	\$198,060	<b>\$8,263.25</b>
		I: \$0	\$0	I: \$0	\$0	Revised Tax
<b>TOTALS :</b>		<b>\$924,877</b>	<b>\$268,210</b>	<b>\$682,980</b>	<b>\$198,060</b>	<b>\$23,330.28</b>

Skye Phillips 2/5/2021  
 Appraiser Date

Certified Residential Appraiser

PETITION FOR ABATEMENT OR REFUND OF TAXES **RECEIVED**

County: Adams

Date Received JAN 19 2021  
(Use Assessor's or Commissioners' Date Stamp)

**Section I:** Petitioner, please complete Section I only.

**OFFICE OF THE  
ADAMS COUNTY ASSESSOR**

Date: January 13, 2021  
Month Day Year

Petitioner's Name: 40Th & Chambers LLC  
Petitioner's Mailing Address: c/o Ryan LLC, 1899 Broadway, Suite 4100  
Denver, CO 80202  
City or Town State Zip Code

SCHEDULE OR PARCEL NUMBER(S)	PROPERTY ADDRESS OR LEGAL DESCRIPTION OF PROPERTY
<u>R0083906 &amp;</u>	<u>4249 HUNT RD</u>
<u>R0179912</u>	<u>4249 HUNT RD</u>

Petitioner states that the taxes assessed against the above property for the property tax year 2020 are incorrect for the following reasons: (Briefly describe the circumstances surrounding the incorrect value or tax. Attach additional sheets if necessary.)

We are appealing this property to match the 2019 stipulated value.

Petitioner's estimate of value: \$ 1,228,392 ( 2020 )  
Value Year

Petitioner requests an abatement or refund of the appropriate taxes.

I declare, under penalty of perjury in the second degree, that this petition, together with any accompanying exhibits or statements, has been prepared or examined by me, and to the best of my knowledge, information and belief, is true, correct, and complete.

\_\_\_\_\_  
Petitioner's Signature Daytime Phone Number ( )  
By Michelle Tarbell  
Agent's Signature\* Michelle Tarbell Daytime Phone Number ( 303 ) 222-1861  
michelle.tarbell@ryan.com

\*Letter of agency must be attached when petition is submitted by an agent.

If the board of county commissioners, pursuant to section 39-10-114(1), or the property tax administrator, pursuant to section 39-2-116, denies the petition for refund or abatement of taxes in whole or in part, the petitioner may appeal to the board of assessment appeals pursuant to the provisions of section 39-2-125 within thirty days of the entry of any such decision, § 39-10-114.5(1), C.R.S.

**Section II: Assessor's Recommendation**  
(For Assessor's Use Only)

Tax Year \_\_\_\_\_

	Actual	Assessed	Tax
Original	_____	_____	_____
Corrected	_____	_____	_____
Abate/Refund	_____	_____	_____

Assessor recommends approval as outlined above.  
No protest was filed for the year: \_\_\_\_\_ (If a protest was filed, please attach a copy of the NOD.)

Assessor recommends denial for the following reason(s):  
\_\_\_\_\_  
\_\_\_\_\_

\_\_\_\_\_  
Assessor's or Deputy Assessor's Signature

**FOR ASSESSORS AND COUNTY COMMISSIONERS USE ONLY**

(Section III or Section IV must be completed)

Every petition for abatement or refund filed pursuant to section 39-10-114 shall be acted upon pursuant to the provisions of this section by the board of county commissioners or the assessor, as appropriate, within six months of the date of filing such petition, § 39-1-113(1.7), C.R.S.

**Section III:**

**Written Mutual Agreement of Assessor and Petitioner**

(Only for abatements up to \$1,000)

The commissioners of \_\_\_\_\_ County authorize the assessor by Resolution No. \_\_\_\_\_ to review petitions for abatement or refund and to settle by written mutual agreement any such petition for abatement or refund in an amount of one thousand dollars or less per tract, parcel, or lot of land or per schedule of personal property, in accordance with § 39-1-113(1.5), C.R.S.

The assessor and petitioner mutually agree to the values and tax abatement/refund of:

	Tax Year _____		
	Actual	Assessed	Tax
Original	_____	_____	_____
Corrected	_____	_____	_____
Abate/Refund	_____	_____	_____

Note: The total tax amount does not include accrued interest, penalties, and fees associated with late and/or delinquent tax payments, if applicable. Please contact the county treasurer for full payment information.

Petitioner's Signature \_\_\_\_\_ Date \_\_\_\_\_

Assessor's or Deputy Assessor's Signature \_\_\_\_\_ Date \_\_\_\_\_

**Section IV:**

**Decision of the County Commissioners**

(Must be completed if Section III does not apply)

WHEREAS, The County Commissioners of \_\_\_\_\_ County, State of Colorado, at a duly and lawfully called regular meeting held on \_\_\_\_\_ / \_\_\_\_\_ / \_\_\_\_\_, at which meeting there were present the following members:

Month Day Year

with notice of such meeting and an opportunity to be present having been given to the taxpayer and the Assessor of said County and Assessor \_\_\_\_\_ (*being present--not present*) and petitioner \_\_\_\_\_ (*being present--not present*), and WHEREAS, The said

County Commissioners have carefully considered the within petition, and are fully advised in relation thereto, NOW BE IT RESOLVED, That the Board (*agrees--does not agree*) with the recommendation of the assessor and the petition be (*approved--approved in part--denied*) with an abatement/refund as follows:

Year	Assessed Value	Taxes Abate/Refund
_____	_____	_____

\_\_\_\_\_  
Chairperson of the Board of County Commissioners' Signature

I, \_\_\_\_\_ County Clerk and Ex-officio Clerk of the Board of County Commissioners in and for the aforementioned county, do hereby certify that the above and foregoing order is truly copied from the record of the proceedings of the Board of County Commissioners.

IN WITNESS WHEREOF, I have hereunto set my hand and affixed the seal of said County

this \_\_\_\_\_ day of \_\_\_\_\_, \_\_\_\_\_  
Month Year  
\_\_\_\_\_  
County Clerk's or Deputy County Clerk's Signature

Note: Abatements greater than \$1,000 per schedule, per year, must be submitted in duplicate to the Property Tax Administrator for review.

**Section V:**

**Action of the Property Tax Administrator**

(For all abatements greater than \$1,000)

The action of the Board of County Commissioners, relative to the within petition, is hereby

Approved  Approved in part \$ \_\_\_\_\_  Denied for the following reason(s):

\_\_\_\_\_  
Secretary's Signature Property Tax Administrator's Signature Date



<b>BOARD OF ASSESSMENT APPEALS, State of Colorado</b> 1313 Sherman Street, Room 315 Denver, Colorado 80203	
<b>Petitioner:</b> 40 <sup>th</sup> CHAMBERS LLC  <b>Respondent:</b> ADAMS COUNTY BOARD OF EQUALIZATION	<b>▲ COURT USE ONLY ▲</b>
<b>Attorneys for Respondent:</b> Adams County Attorney's Office Meredith P. Van Horn, #42487 Assistant County Attorney 4430 S. Adams County Parkway 5 <sup>th</sup> Floor, Suite C5000B Brighton, Colorado 80601 Telephone: 720-523-6116 Fax: 720-523-6114	Docket Number: 78638  Multiple County Account Numbers: R0179912 R0083906 (As set forth in Attachment A)
<b>STIPULATION (As to Tax Year 2019 Actual Value)</b>	

Petitioner and Respondent hereby enter into this Stipulation regarding the tax year 2019 valuation of the subject property, and jointly move the Board of Assessment Appeals to enter its order based on this Stipulation.

Petitioner and Respondent agree and stipulate as follows:

1. The properties subject to this Stipulation are described as set forth in the County Schedule Numbers on the attachment to this Stipulation.
2. The subject properties are classified as Vacant Land properties.
3. The attachment to this stipulation reflects the actual values of the subject properties, as assigned by the Adams County Board of Equalization for tax year 2019.
4. After further review and negotiation, the Petitioner and Respondent agree to the tax year 2019 actual values of the subject properties, as shown on the attachment to this stipulation.

**Total 2019 Proposed Value:      \$1,228,392**

5. Both parties stipulate and agree that the valuations as established on the attachment to this stipulation are binding with respect to tax year 2019 and that further adjustment, whether brought under legal or factual grounds, shall be precluded.

6. Brief narrative as to why the reductions were made: After further review of the market, the 2019 value was lowered to the market value range.

7. Both parties agree that the hearing scheduled before the Board of Assessment Appeals on \_\_\_\_\_ at 8:30 a.m., be vacated; or a hearing has not yet been scheduled before the Board of Assessment Appeals   x   (check if appropriate).

DATED this   23<sup>rd</sup>   day of April, 2020.

*Michelle Tarbell*

---

Michelle Tarbell  
Ryan LLC  
7979 E. Tufts Ave.  
Suite 1500  
Denver, Colorado 80237  
Telephone: 303-222-1858  
Email: [michelle.tarbell@ryan.com](mailto:michelle.tarbell@ryan.com)

*Meredith P. Van Horn*

---

Meredith P. Van Horn, #42487  
Assistant Adams County Attorney  
4430 S. Adams County Parkway  
Suite C5000B  
Brighton, Colorado 80601  
Telephone: 720-523-6116  
[mvanhorn@adcogov.org](mailto:mvanhorn@adcogov.org)

Docket Number: 78638

ATTACHMENT A

**Account Number: R0179912**

Original Value:

Land:	\$738,571
Improvements:	\$ 0
Total:	\$738,571

Value after BOE Appeal:

Land:	\$738,571
Improvements:	\$ 0
Total:	\$738,571

Stipulated Value:

Land:	\$545,412
Improvements:	\$ 0
Total:	\$545,412

**Account Number: R0083906**

Original Value:

Land:	\$924,877
Improvements:	\$ 0
Total:	\$924,877

Value after BOE Appeal:

Land:	\$924,877
Improvements:	\$ 0
Total:	\$924,877

Stipulated Value:

Land:	\$682,980
Improvements:	\$ 0
Total:	\$682,980

**TOTAL NEW VALUE OF ACCOUNTS = \$1,228,392**

LETTER OF AUTHORIZATION  
FOR PROPERTY TAX REPRESENTATION

40Th Chambers LLC

---

Property Owner

R0083906 & R0179912, 4243 HUNT RD & 4243 Hunt Rd

---

Subject Property

Adams County, CO

---

Jurisdiction and State

2019/2020

---

Year

This letter authorizes Ryan, LLC and its affiliate, Ryan Tax Compliance Services, LLC to represent the above-named property as its property tax agent in the jurisdiction and state named above. This authorization includes, but is not limited to: filing property renditions or returns; signing and filing appeals; examining property tax records; and, appearances before the assessor, boards of equalization or review, or other governmental agencies responsible for the assessment of property.

If there are any questions concerning this authorization, please contact the following:  
Michelle Tarbell, (720) 524-0022, Michelle.Tarbell@ryan.com

A copy of any application or appeal attached to this authorization has been provided to the undersigned property owner. A facsimile or scanned image of a signature below shall constitute an original signing of this authorization and the document containing the original signature will be submitted upon request.

This authorization shall remain effective as long as permitted by law or until revoked in writing by the owner. The person signing below certifies that they are a duly appointed officer, representative or agent of the owner and that they have the legal capacity to execute this authorization.

Property Owner:

 Valerie Hilliard 5/9/2019  
Signature Printed Name Date

Property Tax Manager

Title

Sworn and subscribed before me this 9<sup>th</sup> day of May, 2019.

  
Notary Public  
My commission expires: May 27, 2021

Atrium Hospitality  
Denver Vacant Land

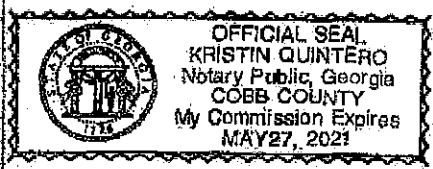

PETITION FOR ABATEMENT OR REFUND OF TAXES **RECEIVED**

County: Adams

Date Received JAN 19 2021  
(Use Assessor's or Commissioners' Date Stamp)

**Section I: Petitioner, please complete Section I only.**

**OFFICE OF THE  
ADAMS COUNTY ASSESSOR**

Date: January 13, 2021  
Month Day Year

Petitioner's Name: 40Th & Chambers LLC  
Petitioner's Mailing Address: c/o Ryan LLC, 1899 Broadway, Suite 4100  
Denver, CO 80202  
City or Town State Zip Code

SCHEDULE OR PARCEL NUMBER(S)	PROPERTY ADDRESS OR LEGAL DESCRIPTION OF PROPERTY
<u>R0083906 &amp;</u>	<u>4249 HUNT RD</u>
<u>R0179912</u>	<u>4249 HUNT RD</u>

Petitioner states that the taxes assessed against the above property for the property tax year 2020 are incorrect for the following reasons: (Briefly describe the circumstances surrounding the incorrect value or tax. Attach additional sheets if necessary.)

We are appealing this property to match the 2019 stipulated value.

Petitioner's estimate of value: \$ 1,228,392 ( 2020 )  
Value Year

Petitioner requests an abatement or refund of the appropriate taxes.

I declare, under penalty of perjury in the second degree, that this petition, together with any accompanying exhibits or statements, has been prepared or examined by me, and to the best of my knowledge, information and belief, is true, correct, and complete.

Petitioner's Signature \_\_\_\_\_ Daytime Phone Number ( \_\_\_\_\_ )  
By Michelle Tarbell Daytime Phone Number ( 303 ) 222-1861  
Agent's Signature\* Michelle Tarbell michelle.tarbell@ryan.com

\*Letter of agency must be attached when petition is submitted by an agent.

If the board of county commissioners, pursuant to section 39-10-114(1), or the property tax administrator, pursuant to section 39-2-116, denies the petition for refund or abatement of taxes in whole or in part, the petitioner may appeal to the board of assessment appeals pursuant to the provisions of section 39-2-125 within thirty days of the entry of any such decision, § 39-10-114.5(1), C.R.S.

**Section II: Assessor's Recommendation**  
(For Assessor's Use Only)

Tax Year \_\_\_\_\_

	Actual	Assessed	Tax
Original	_____	_____	_____
Corrected	_____	_____	_____
Abate/Refund	_____	_____	_____

Assessor recommends approval as outlined above.  
No protest was filed for the year: \_\_\_\_\_ (If a protest was filed, please attach a copy of the NOD.)

Assessor recommends denial for the following reason(s): \_\_\_\_\_

\_\_\_\_\_  
Assessor's or Deputy Assessor's Signature

**FOR ASSESSORS AND COUNTY COMMISSIONERS USE ONLY**

(Section III or Section IV must be completed)

Every petition for abatement or refund filed pursuant to section 39-10-114 shall be acted upon pursuant to the provisions of this section by the board of county commissioners or the assessor, as appropriate, within six months of the date of filing such petition, § 39-1-113(1.7), C.R.S.

<b>Section III: Written Mutual Agreement of Assessor and Petitioner</b>			
(Only for abatements up to \$1,000)			
The commissioners of _____ County authorize the assessor by Resolution No. _____ to review petitions for abatement or refund and to settle by written mutual agreement any such petition for abatement or refund in an amount of one thousand dollars or less per tract, parcel, or lot of land or per schedule of personal property, in accordance with § 39-1-113(1.5), C.R.S.			
<b>The assessor and petitioner mutually agree to the values and tax abatement/refund of:</b>			
	Tax Year _____		
	<u>Actual</u>	<u>Assessed</u>	<u>Tax</u>
Original	_____	_____	_____
Corrected	_____	_____	_____
Abate/Refund	_____	_____	_____
Note: The total tax amount does not include accrued interest, penalties, and fees associated with late and/or delinquent tax payments, if applicable. Please contact the county treasurer for full payment information.			
Petitioner's Signature _____		Date _____	
Assessor's or Deputy Assessor's Signature _____		Date _____	

<b>Section IV: Decision of the County Commissioners</b>							
(Must be completed if Section III does not apply)							
WHEREAS, The County Commissioners of _____ County, State of Colorado, at a duly and lawfully called regular meeting held on ____/____/____, at which meeting there were present the following members:							
_____ <small>Month Day Year</small>							
with notice of such meeting and an opportunity to be present having been given to the taxpayer and the Assessor of said County and Assessor _____ <i>(being present--not present)</i> and petitioner _____ <i>(being present--not present)</i> , and WHEREAS, The said							
<small>Name Name</small>							
County Commissioners have carefully considered the within petition, and are fully advised in relation thereto, NOW BE IT RESOLVED, That the Board <i>(agrees--does not agree)</i> with the recommendation of the assessor and the petition be <i>(approved--approved in part--denied)</i> with an abatement/refund as follows:							
<table border="1" style="width:100%; border-collapse: collapse;"> <thead> <tr> <th style="width:15%;">Year</th> <th style="width:40%;">Assessed Value</th> <th style="width:45%;">Taxes Abate/Refund</th> </tr> </thead> <tbody> <tr> <td> </td> <td> </td> <td> </td> </tr> </tbody> </table>	Year	Assessed Value	Taxes Abate/Refund				_____ Chairperson of the Board of County Commissioners' Signature
Year	Assessed Value	Taxes Abate/Refund					
I, _____ County Clerk and Ex-officio Clerk of the Board of County Commissioners in and for the aforementioned county, do hereby certify that the above and foregoing order is truly copied from the record of the proceedings of the Board of County Commissioners.							
IN WITNESS WHEREOF, I have hereunto set my hand and affixed the seal of said County							
this _____ day of _____	_____ County Clerk's or Deputy County Clerk's Signature						
<small>Month Year</small>							
Note: Abatements greater than \$1,000 per schedule, per year, must be submitted in duplicate to the Property Tax Administrator for review.							

<b>Section V: Action of the Property Tax Administrator</b>		
(For all abatements greater than \$1,000)		
The action of the Board of County Commissioners, relative to the within petition, is hereby		
<input type="checkbox"/> Approved <input type="checkbox"/> Approved in part \$ _____ <input type="checkbox"/> Denied for the following reason(s):		
_____		
_____ Secretary's Signature	_____ Property Tax Administrator's Signature	_____ Date

<b>BOARD OF ASSESSMENT APPEALS, State of Colorado</b> 1313 Sherman Street, Room 315 Denver, Colorado 80203	
<b>Petitioner:</b> 40 <sup>th</sup> CHAMBERS LLC  <b>Respondent:</b> ADAMS COUNTY BOARD OF EQUALIZATION	<b>▲ COURT USE ONLY ▲</b>
<b>Attorneys for Respondent:</b> Adams County Attorney's Office Meredith P. Van Horn, #42487 Assistant County Attorney 4430 S. Adams County Parkway 5 <sup>th</sup> Floor, Suite C5000B Brighton, Colorado 80601 Telephone: 720-523-6116 Fax: 720-523-6114	Docket Number: 78638  Multiple County Account Numbers: R0179912 R0083906 (As set forth in Attachment A)
<b>STIPULATION (As to Tax Year 2019 Actual Value)</b>	

Petitioner and Respondent hereby enter into this Stipulation regarding the tax year 2019 valuation of the subject property, and jointly move the Board of Assessment Appeals to enter its order based on this Stipulation.

Petitioner and Respondent agree and stipulate as follows:

1. The properties subject to this Stipulation are described as set forth in the County Schedule Numbers on the attachment to this Stipulation.
2. The subject properties are classified as Vacant Land properties.
3. The attachment to this stipulation reflects the actual values of the subject properties, as assigned by the Adams County Board of Equalization for tax year 2019.
4. After further review and negotiation, the Petitioner and Respondent agree to the tax year 2019 actual values of the subject properties, as shown on the attachment to this stipulation.

**Total 2019 Proposed Value:      \$1,228,392**

5. Both parties stipulate and agree that the valuations as established on the attachment to this stipulation are binding with respect to tax year 2019 and that further adjustment, whether brought under legal or factual grounds, shall be precluded.

6. Brief narrative as to why the reductions were made: After further review of the market, the 2019 value was lowered to the market value range.

7. Both parties agree that the hearing scheduled before the Board of Assessment Appeals on \_\_\_\_\_ at 8:30 a.m., be vacated; or a hearing has not yet been scheduled before the Board of Assessment Appeals   x   (check if appropriate).

DATED this   23<sup>rd</sup>   day of April, 2020.

*Michelle Tarbell*

---

Michelle Tarbell  
Ryan LLC  
7979 E. Tufts Ave.  
Suite 1500  
Denver, Colorado 80237  
Telephone: 303-222-1858  
Email: [michelle.tarbell@ryan.com](mailto:michelle.tarbell@ryan.com)

*Meredith P. Van Horn*

---

Meredith P. Van Horn, #42487  
Assistant Adams County Attorney  
4430 S. Adams County Parkway  
Suite C5000B  
Brighton, Colorado 80601  
Telephone: 720-523-6116  
[mvanhorn@adcogov.org](mailto:mvanhorn@adcogov.org)

Docket Number: 78638



ATTACHMENT A

**Account Number: R0179912**

Original Value:

Land:	\$738,571
Improvements:	\$ 0
Total:	\$738,571

Value after BOE Appeal:

Land:	\$738,571
Improvements:	\$ 0
Total:	\$738,571

Stipulated Value:

Land:	\$545,412
Improvements:	\$ 0
Total:	\$545,412

**Account Number: R0083906**

Original Value:

Land:	\$924,877
Improvements:	\$ 0
Total:	\$924,877

Value after BOE Appeal:

Land:	\$924,877
Improvements:	\$ 0
Total:	\$924,877

Stipulated Value:

Land:	\$682,980
Improvements:	\$ 0
Total:	\$682,980

**TOTAL NEW VALUE OF ACCOUNTS = \$1,228,392**

LETTER OF AUTHORIZATION  
FOR PROPERTY TAX REPRESENTATION

40Th Chambers LLC

---

Property Owner

R0083906 & R0179912, 4243 HUNT RD & 4243 Hunt Rd

---

Subject Property

Adams County, CO

---

Jurisdiction and State

2019/2020

---

Year

This letter authorizes Ryan, LLC and its affiliate, Ryan Tax Compliance Services, LLC to represent the above-named property as its property tax agent in the jurisdiction and state named above. This authorization includes, but is not limited to: filing property renditions or returns; signing and filing appeals; examining property tax records; and, appearances before the assessor, boards of equalization or review, or other governmental agencies responsible for the assessment of property.

If there are any questions concerning this authorization, please contact the following:  
Michelle Tarbell, (720) 524-0022, Michelle.Tarbell@ryan.com

A copy of any application or appeal attached to this authorization has been provided to the undersigned property owner. A facsimile or scanned image of a signature below shall constitute an original signing of this authorization and the document containing the original signature will be submitted upon request.

This authorization shall remain effective as long as permitted by law or until revoked in writing by the owner. The person signing below certifies that they are a duly appointed officer, representative or agent of the owner and that they have the legal capacity to execute this authorization.

Property Owner:

Valerie Hilliard Valerie Hilliard 5/9/2019  
Signature Printed Name Date

Property Tax Manager

Title

Sworn and subscribed before me this 9<sup>th</sup> day of May, 2019.

Kristin Quintero  
Notary Public  
My commission expires: May 27, 2021

Atrium Hospitality  
Denver Vacant Land

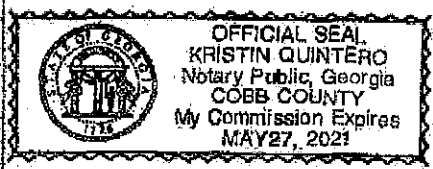

**ASSESSOR'S RECOMMENDATION COUNTY BOARD OF EQUALIZATION**

Account No : R0083906 Parcel No : 0182100007001  
 Petition Year : 2020 Date Filed : January 13, 2021  
 Owner Entity : 40th Chambers, LLC / C/O Atrium Hospitality  
 Owner Address : 12735 Morris Road Ext STE. 400  
 Owner City : Alpharetta State : GA

Property Location :

TYPE	OCC CODE	PETITIONER'S REQUESTED VALUES		ASSESSOR'S ASSIGNED VALUES		ORIGINAL TAX WARRANT
		Actual Value	Assessed Value	Actual Value	Assessed Value	
REAL		L: \$682,762	\$198,000	L: \$924,877	\$268,210	A. Ratio 29.00%
		I: \$0	\$0	I: \$0	\$0	Mill Levy 117.794
<b>TOTALS :</b>		<b>\$682,762</b>	<b>\$198,000</b>	<b>\$924,877</b>	<b>\$268,210</b>	Original Tax <b>\$31,594</b>

**Tax Exempt Portion**  
0%

**Petitioner's Statement :**

**Assessor's Report**

**Situation :**

This account came off of present worth discounting to a value higher than market value.

**Action :**

Decreased the value to what the market value is indicating.

**Recommendation :**

Upon further review, a reduction in value appears warranted.

**ASSESSOR'S RECOMMENDED ADJUSTMENT**

TYPE	OCC CODE	ASSESSOR'S ASSIGNED VALUE		RECOMMENDED VALUE		REVISED TAX WARRANT
		Actual Value	Assessed Value	Actual Value	Assessed Value	Tax Refund
REAL		L: \$924,877	\$268,210	L: \$682,980	\$198,060	\$8,263.25
		I: \$0	\$0	I: \$0	\$0	Revised Tax
<b>TOTALS :</b>		<b>\$924,877</b>	<b>\$268,210</b>	<b>\$682,980</b>	<b>\$198,060</b>	<b>\$23,330.28</b>

Skye Phillips 2/5/2021  
 Appraiser Date

Certified Residential Appraiser

**Ken Musso**  
Assessor



Assessor's Office  
4430 South Adams County Parkway  
2nd Floor, Suite C2100  
Brighton, CO 80601-8201  
Phone 720-523-6038  
Fax 720-523-6037  
www.adcogov.org

**BOARD OF COUNTY COMMISSIONERS**

**STIPULATION (As to Tax Year(s) 2020 Actual Value(s))**

1. The property subject to this Stipulation is:  
Schedule No. (S): R0179912 Parcel NO.(S) 0182100007001
  
2. The subject property is classified as a Vacant Land property.
  
3. The County Assessor originally assigned the following actual value to the subject property for tax year(s) 2020 :  
  
Land \$738,571
  
4. The Adams County Assessor has reviewed this file and agrees to make the following adjustment to the valuation for the subject property for tax year(s) 2020 :  
  
Land \$545,412
  
5. By entering into this agreement, the Petitioner understands that they are giving up rights to further appeal of the value of this property for tax year(s) 2020.

DATED this: February 4th, 2021

Michelle Tarbell  
Petitioner's Representative  
Ryan, LLC  
1999 Broadway, suite 4100  
Denver, CO 80202

Steve Phillips  
Assessor Representative  
Adams County Assessor's Office

**ASSESSOR'S RECOMMENDATION  
BOARD OF EQUALIZATION**

Account No : R0179912 Parcel No : 0182100007001  
 Petition Year : 2020 Date Filed : January 13, 2021  
 Owner Entity : 40th Chambers, LLC / C/O Atrium Hospitality  
 Owner Address : 12735 Morris Road, EXT STE 400  
 Owner City : Alpharetta State : GA

Property Location :

TYPE	OCC CODE	PETITIONER'S REQUESTED VALUES		ASSESSOR'S ASSIGNED VALUES		ORIGINAL TAX WARRANT
		Actual Value	Assessed Value	Actual Value	Assessed Value	
REAL		L: \$545,238	\$158,120	L: \$738,571	\$214,190	A. Ratio 29.00%
		I: \$0	\$0	I: \$0	\$0	Mill Levy 134.554
<b>TOTALS :</b>		<b>\$545,238</b>	<b>\$158,120</b>	<b>\$738,571</b>	<b>\$214,190</b>	Original Tax <b>\$28,820</b>

**Tax Exempt Portion**  
0%

**Petitioner's Statement :**

**Assessor's Report**

**Situation :**  
This property came off of present worth discounting at a value above market value.

**Action :**  
Lowered the value to represent the market value.

**Recommendation :**  
Upon further review, a reduction in value appears warranted.

**ASSESSOR'S RECOMMENDED ADJUSTMENT**

TYPE	OCC CODE	ASSESSOR'S ASSIGNED VALUE		RECOMMENDED VALUE		REVISED TAX WARRANT
		Actual Value	Assessed Value	Actual Value	Assessed Value	Tax Refund
REAL		L: \$738,571	\$214,190	L: \$545,412	\$158,170	\$7,537.71
		I: \$0	\$0	I: \$0	\$0	Revised Tax
<b>TOTALS :</b>		<b>\$738,571</b>	<b>\$214,190</b>	<b>\$545,412</b>	<b>\$158,170</b>	<b>\$21,282.41</b>

Skye Phillips 2/5/2021  
 Appraiser Date

Certified Residential Appraiser

PETITION FOR ABATEMENT OR REFUND OF TAXES **RECEIVED**

County: Adams

Date Received JAN 19 2021  
(Use Assessor's or Commissioners' Date Stamp)

**Section I: Petitioner, please complete Section I only.**

**OFFICE OF THE  
ADAMS COUNTY ASSESSOR**

Date: January 13, 2021  
Month Day Year

Petitioner's Name: 40Th & Chambers LLC  
Petitioner's Mailing Address: c/o Ryan LLC, 1899 Broadway, Suite 4100  
Denver, CO 80202  
City or Town State Zip Code

SCHEDULE OR PARCEL NUMBER(S)	PROPERTY ADDRESS OR LEGAL DESCRIPTION OF PROPERTY
<u>R0083906 &amp;</u>	<u>4249 HUNT RD</u>
<u>R0179912</u>	<u>4249 HUNT RD</u>

Petitioner states that the taxes assessed against the above property for the property tax year 2020 are incorrect for the following reasons: (Briefly describe the circumstances surrounding the incorrect value or tax. Attach additional sheets if necessary.)

We are appealing this property to match the 2019 stipulated value.

Petitioner's estimate of value: \$ 1,228,392 ( 2020 )  
Value Year

Petitioner requests an abatement or refund of the appropriate taxes.

I declare, under penalty of perjury in the second degree, that this petition, together with any accompanying exhibits or statements, has been prepared or examined by me, and to the best of my knowledge, information and belief, is true, correct, and complete.

Petitioner's Signature \_\_\_\_\_ Daytime Phone Number ( \_\_\_\_\_ )  
By Michelle Tarbell Daytime Phone Number ( 303 ) 222-1861  
Agent's Signature\* Michelle Tarbell michelle.tarbell@ryan.com

\*Letter of agency must be attached when petition is submitted by an agent.

If the board of county commissioners, pursuant to section 39-10-114(1), or the property tax administrator, pursuant to section 39-2-116, denies the petition for refund or abatement of taxes in whole or in part, the petitioner may appeal to the board of assessment appeals pursuant to the provisions of section 39-2-125 within thirty days of the entry of any such decision, § 39-10-114.5(1), C.R.S.

**Section II: Assessor's Recommendation**  
(For Assessor's Use Only)

Tax Year \_\_\_\_\_

	Actual	Assessed	Tax
Original	_____	_____	_____
Corrected	_____	_____	_____
Abate/Refund	_____	_____	_____

Assessor recommends approval as outlined above.  
No protest was filed for the year: \_\_\_\_\_ (If a protest was filed, please attach a copy of the NOD.)

Assessor recommends denial for the following reason(s):  
\_\_\_\_\_

Assessor's or Deputy Assessor's Signature \_\_\_\_\_

**FOR ASSESSORS AND COUNTY COMMISSIONERS USE ONLY**

(Section III or Section IV must be completed)

Every petition for abatement or refund filed pursuant to section 39-10-114 shall be acted upon pursuant to the provisions of this section by the board of county commissioners or the assessor, as appropriate, within six months of the date of filing such petition, § 39-1-113(1.7), C.R.S.

**Section III:**

**Written Mutual Agreement of Assessor and Petitioner**

(Only for abatements up to \$1,000)

The commissioners of \_\_\_\_\_ County authorize the assessor by Resolution No. \_\_\_\_\_ to review petitions for abatement or refund and to settle by written mutual agreement any such petition for abatement or refund in an amount of one thousand dollars or less per tract, parcel, or lot of land or per schedule of personal property, in accordance with § 39-1-113(1.5), C.R.S.

The assessor and petitioner mutually agree to the values and tax abatement/refund of:

	Tax Year _____		
	<u>Actual</u>	<u>Assessed</u>	<u>Tax</u>
Original	_____	_____	_____
Corrected	_____	_____	_____
Abate/Refund	_____	_____	_____

Note: The total tax amount does not include accrued interest, penalties, and fees associated with late and/or delinquent tax payments, if applicable. Please contact the county treasurer for full payment information.

Petitioner's Signature \_\_\_\_\_ Date \_\_\_\_\_  
 Assessor's or Deputy Assessor's Signature \_\_\_\_\_ Date \_\_\_\_\_

**Section IV:**

**Decision of the County Commissioners**

(Must be completed if Section III does not apply)

WHEREAS, The County Commissioners of \_\_\_\_\_ County, State of Colorado, at a duly and lawfully called regular meeting held on \_\_\_\_/\_\_\_\_/\_\_\_\_, at which meeting there were present the following members:

Month Day Year

with notice of such meeting and an opportunity to be present having been given to the taxpayer and the Assessor of said County and Assessor \_\_\_\_\_ (*being present--not present*) and petitioner \_\_\_\_\_ (*being present--not present*), and WHEREAS, The said

County Commissioners have carefully considered the within petition, and are fully advised in relation thereto, NOW BE IT RESOLVED, That the Board (*agrees--does not agree*) with the recommendation of the assessor and the petition be (*approved--approved in part--denied*) with an abatement/refund as follows:

Year	Assessed Value	Taxes Abate/Refund
_____	_____	_____

\_\_\_\_\_  
 Chairperson of the Board of County Commissioners' Signature

I, \_\_\_\_\_ County Clerk and Ex-officio Clerk of the Board of County Commissioners in and for the aforementioned county, do hereby certify that the above and foregoing order is truly copied from the record of the proceedings of the Board of County Commissioners.

IN WITNESS WHEREOF, I have hereunto set my hand and affixed the seal of said County

this \_\_\_\_ day of \_\_\_\_\_  
 Month Year \_\_\_\_\_  
 County Clerk's or Deputy County Clerk's Signature

Note: Abatements greater than \$1,000 per schedule, per year, must be submitted in duplicate to the Property Tax Administrator for review.

**Section V:**

**Action of the Property Tax Administrator**

(For all abatements greater than \$1,000)

The action of the Board of County Commissioners, relative to the within petition, is hereby

Approved  Approved in part \$ \_\_\_\_\_  Denied for the following reason(s):

Secretary's Signature \_\_\_\_\_ Property Tax Administrator's Signature \_\_\_\_\_ Date \_\_\_\_\_

<b>BOARD OF ASSESSMENT APPEALS, State of Colorado</b> 1313 Sherman Street, Room 315 Denver, Colorado 80203	
<b>Petitioner:</b> 40 <sup>th</sup> CHAMBERS LLC  <b>Respondent:</b> ADAMS COUNTY BOARD OF EQUALIZATION	<b>▲ COURT USE ONLY ▲</b>
<b>Attorneys for Respondent:</b> Adams County Attorney's Office Meredith P. Van Horn, #42487 Assistant County Attorney 4430 S. Adams County Parkway 5 <sup>th</sup> Floor, Suite C5000B Brighton, Colorado 80601 Telephone: 720-523-6116 Fax: 720-523-6114	Docket Number: 78638  Multiple County Account Numbers: R0179912 R0083906 (As set forth in Attachment A)
<b>STIPULATION (As to Tax Year 2019 Actual Value)</b>	

Petitioner and Respondent hereby enter into this Stipulation regarding the tax year 2019 valuation of the subject property, and jointly move the Board of Assessment Appeals to enter its order based on this Stipulation.

Petitioner and Respondent agree and stipulate as follows:

1. The properties subject to this Stipulation are described as set forth in the County Schedule Numbers on the attachment to this Stipulation.
2. The subject properties are classified as Vacant Land properties.
3. The attachment to this stipulation reflects the actual values of the subject properties, as assigned by the Adams County Board of Equalization for tax year 2019.
4. After further review and negotiation, the Petitioner and Respondent agree to the tax year 2019 actual values of the subject properties, as shown on the attachment to this stipulation.

**Total 2019 Proposed Value:      \$1,228,392**



5. Both parties stipulate and agree that the valuations as established on the attachment to this stipulation are binding with respect to tax year 2019 and that further adjustment, whether brought under legal or factual grounds, shall be precluded.

6. Brief narrative as to why the reductions were made: After further review of the market, the 2019 value was lowered to the market value range.

7. Both parties agree that the hearing scheduled before the Board of Assessment Appeals on \_\_\_\_\_ at 8:30 a.m., be vacated; or a hearing has not yet been scheduled before the Board of Assessment Appeals   x   (check if appropriate).

DATED this   23<sup>rd</sup>   day of April, 2020.

*Michelle Tarbell*

---

Michelle Tarbell  
Ryan LLC  
7979 E. Tufts Ave.  
Suite 1500  
Denver, Colorado 80237  
Telephone: 303-222-1858  
Email: [michelle.tarbell@ryan.com](mailto:michelle.tarbell@ryan.com)

*Meredith P. Van Horn*

---

Meredith P. Van Horn, #42487  
Assistant Adams County Attorney  
4430 S. Adams County Parkway  
Suite C5000B  
Brighton, Colorado 80601  
Telephone: 720-523-6116  
[mvanhorn@adcogov.org](mailto:mvanhorn@adcogov.org)

Docket Number: 78638

ATTACHMENT A

**Account Number: R0179912**

Original Value:

Land:	\$738,571
Improvements:	\$ 0
Total:	\$738,571

Value after BOE Appeal:

Land:	\$738,571
Improvements:	\$ 0
Total:	\$738,571

Stipulated Value:

Land:	\$545,412
Improvements:	\$ 0
Total:	\$545,412

**Account Number: R0083906**

Original Value:

Land:	\$924,877
Improvements:	\$ 0
Total:	\$924,877

Value after BOE Appeal:

Land:	\$924,877
Improvements:	\$ 0
Total:	\$924,877

Stipulated Value:

Land:	\$682,980
Improvements:	\$ 0
Total:	\$682,980

**TOTAL NEW VALUE OF ACCOUNTS = \$1,228,392**

LETTER OF AUTHORIZATION  
FOR PROPERTY TAX REPRESENTATION

40Th Chambers LLC

---

Property Owner

R0083906 & R0179912, 4243 HUNT RD & 4243 Hunt Rd

---

Subject Property

Adams County, CO

---

Jurisdiction and State

2019/2020

---

Year

This letter authorizes Ryan, LLC and its affiliate, Ryan Tax Compliance Services, LLC to represent the above-named property as its property tax agent in the jurisdiction and state named above. This authorization includes, but is not limited to: filing property renditions or returns; signing and filing appeals; examining property tax records; and, appearances before the assessor, boards of equalization or review, or other governmental agencies responsible for the assessment of property.

If there are any questions concerning this authorization, please contact the following:  
Michelle Tarbell, (720) 524-0022, Michelle.Tarbell@ryan.com

A copy of any application or appeal attached to this authorization has been provided to the undersigned property owner. A facsimile or scanned image of a signature below shall constitute an original signing of this authorization and the document containing the original signature will be submitted upon request.

This authorization shall remain effective as long as permitted by law or until revoked in writing by the owner. The person signing below certifies that they are a duly appointed officer, representative or agent of the owner and that they have the legal capacity to execute this authorization.

Property Owner:

 Valerie Hilliard 5/9/2019  
Signature Printed Name Date

---

Property Tax Manager

Title

Sworn and subscribed before me this 9<sup>th</sup> day of May, 2019.

  
Notary Public  
My commission expires: May 27, 2021

Atrium Hospitality  
Denver Vacant Land

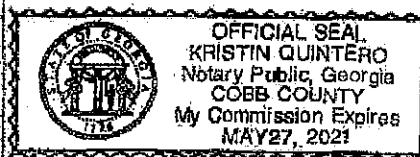

**ASSESSOR'S RECOMMENDATION  
BOARD OF EQUALIZATION**

Account No : R0179912 Parcel No : 0182100007001  
 Petition Year : 2020 Date Filed : January 13, 2021  
 Owner Entity : 40th Chambers, LLC / C/O Atrium Hospitality  
 Owner Address : 12735 Morris Road, EXT STE 400  
 Owner City : Alpharetta State : GA

Property Location :

TYPE	OCC CODE	PETITIONER'S REQUESTED VALUES		ASSESSOR'S ASSIGNED VALUES		ORIGINAL TAX WARRANT
		Actual Value	Assessed Value	Actual Value	Assessed Value	
REAL		L: \$545,238	\$158,120	L: \$738,571	\$214,190	A. Ratio 29.00%
		I: \$0	\$0	I: \$0	\$0	Mill Levy 134.554
<b>TOTALS :</b>		<b>\$545,238</b>	<b>\$158,120</b>	<b>\$738,571</b>	<b>\$214,190</b>	Original Tax <b>\$28,820</b>

**Tax Exempt Portion**  
0%

**Petitioner's Statement :**

**Assessor's Report**

**Situation :**  
This property came off of present worth discounting at a value above market value.

**Action :**  
Lowered the value to represent the market value.

**Recommendation :**  
Upon further review, a reduction in value appears warranted.

**ASSESSOR'S RECOMMENDED ADJUSTMENT**

TYPE	OCC CODE	ASSESSOR'S ASSIGNED VALUE		RECOMMENDED VALUE		REVISED TAX WARRANT
		Actual Value	Assessed Value	Actual Value	Assessed Value	Tax Refund
REAL		L: \$738,571	\$214,190	L: \$545,412	\$158,170	\$7,537.71
		I: \$0	\$0	I: \$0	\$0	Revised Tax
<b>TOTALS :</b>		<b>\$738,571</b>	<b>\$214,190</b>	<b>\$545,412</b>	<b>\$158,170</b>	<b>\$21,282.41</b>

Skye Phillips 2/5/2021  
 Appraiser Date

Certified Residential Appraiser

Ken Musso  
Assessor



Assessor's Office  
4430 South Adams County Parkway  
2nd Floor, Suite C2100  
Brighton, CO 80601-8201  
Phone 720-523-6038  
Fax 720-523-6037  
www.adcogov.org

COUNTY BOARD OF EQUALIZATION

STIPULATION (As to Tax Year(s) 2020 Actual Value(s))

1. The property subject to this Stipulation is:  
Schedule No. (S): R0182140 Parcel NO.(S) 1573-01-3-03-030

2. The subject property is classified as a Residential property.

3. The County Assessor originally assigned the following actual value to the subject property for tax year(s) 2020 :

Land	\$102,000
Improvements	\$420,418
Total	\$522,418

4. The Adams County Assessor has reviewed this file and agrees to make the following adjustment to the valuation for the subject property for tax year(s) 2020 :

Land	\$102,000
Improvements	\$355,500
Total	\$457,500

5. By entering into this agreement, the Petitioner understands that they are giving up rights to further appeal of the value of this property for tax year(s) 2020.

DATED this: August 6, 2020

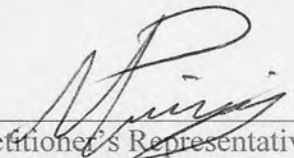
  
\_\_\_\_\_  
Petitioner's Representative  
Michael A. and Maria Paisis  
\_\_\_\_\_  
16365 Columbine Pl  
\_\_\_\_\_  
Thornton Co. 80602  
\_\_\_\_\_

Jeff Maldonado

Digitally signed by Jeff Maldonado  
DN: cn=Jeff Maldonado, o=, email=jemaldonado@adcogov.org, c=US  
Date: 2020.08.06 15:00:24 -0600

\_\_\_\_\_  
Assessor Representative  
Adams County Assessor's Office

**ASSESSOR'S RECOMMENDATION  
BOARD OF COUNTY COMMISSIONERS**

Account No : R0182140 Parcel No : 1573-01-3-03-030  
 Petition Year : 2019 Date Filed : June 2, 2020  
 Owner Entity : Michael and Maria Paisis  
 Owner Address : 16365 Columbine Pl  
 Owner City : Thornton State : Co  
 Property Location : MORRISON SUBD FLG NO 1 AMND NO 1 BLK 4 LOT 12

TYPE	OCC CODE	PETITIONER'S REQUESTED VALUES		ASSESSOR'S ASSIGNED VALUES		ORIGINAL TAX WARRANT
		Actual Value	Assessed Value	Actual Value	Assessed Value	
REAL	100	L:		L:	\$102,000	A. Ratio 7.15%
		I:		I:	\$420,418	Mill Levy 165.675
TOTALS :		\$522,418	\$37,350		\$37,350	Original Tax \$6,188

**Petitioner's Statement :**

Home purchased 5/2019 - requests value changed to purchase price.

**Assessor's Report**

**Situation :**

Confirmed new construction sale and purchase

**Action :**

Value changed for 2020 to May 2019 purchase price.

**Recommendation :**

Upon further review, a reduction in value appears warranted.

**ASSESSOR'S RECOMMENDED ADJUSTMENT**

TYPE	OCC CODE	ASSESSOR'S ASSIGNED VALUE		RECOMMENDED VALUE		REVISED TAX WARRANT	
		Actual Value	Assessed Value	Actual Value	Assessed Value	Tax Refund	
REAL		L:	\$102,000	\$7,290	L:	\$0	\$1,976.50
		I:	\$420,418	\$30,060	I:	\$355,500	\$25,420
TOTALS :		\$522,418	\$37,350	\$457,500	\$25,420	\$4,211.46	

Jeff Maldonado  
Appraiser

November 10,2020  
Date

Appraiser

**Tax Exempt Portion**

0%

PETITION FOR ABATEMENT OR REFUND OF TAXES

County: Adams

Date Received (Use Assessor's or Commissioners' Date Stamp)

Section I: Petitioner, please complete Section I only.

Date: Month Day Year

Petitioner's Name: Michael & Maria Paisis
Petitioner's Mailing Address: 16365 Columbine Pl
Thornton Co 80602
City or Town State Zip Code

Table with 2 columns: SCHEDULE OR PARCEL NUMBER(S) and PROPERTY ADDRESS OR LEGAL DESCRIPTION OF PROPERTY. Row 1: R0182140, 16365 Columbine Pl

Petitioner requests an abatement or refund of the appropriate taxes and states that the taxes assessed against the above property for the property tax year 2020 are incorrect for the following reasons: (Briefly describe why the taxes have been levied erroneously or illegally, whether due to erroneous valuation, irregularity in levying, clerical error, or overvaluation. Attach additional sheets if necessary.)

Petitioner's estimate of value: \$ 457,500 (2020)
Value Year

I declare, under penalty of perjury in the second degree, that this petition, together with any accompanying exhibits or statements, has been prepared or examined by me, and to the best of my knowledge, information, and belief, is true, correct, and complete.

Petitioner's Signature (handwritten)
Daytime Phone Number (723) 423-1022
Email mpaisis@gmail.com
By Agent's Signature\*
Daytime Phone Number ( )
Email

\*Letter of agency must be attached when petition is submitted by an agent.

If the Board of County Commissioners, pursuant to § 39-10-114(1), C.R.S., or the Property Tax Administrator, pursuant to § 39-2-116, C.R.S., denies the petition for refund or abatement of taxes in whole or in part, the Petitioner may appeal to the Board of Assessment Appeals pursuant to the provisions of § 39-2-125, C.R.S., within thirty days of the entry of any such decision, § 39-10-114.5(1), C.R.S.

Section II: Assessor's Recommendation (For Assessor's Use Only)
Tax Year
Actual Assessed Tax
Original
Corrected
Abate/Refund
Assessor recommends approval as outlined above.
If the request for abatement is based upon the grounds of overvaluation, no abatement or refund of taxes shall be made if an objection or protest to such valuation has been filed and a Notice of Determination has been mailed to the taxpayer, § 39-10-114(1)(a)(I)(D), C.R.S.
Tax year: Protest? No Yes (If a protest was filed, please attach a copy of the NOD.)
Assessor recommends denial for the following reason(s):
Assessor's or Deputy Assessor's Signature



**FOR ASSESSORS AND COUNTY COMMISSIONERS USE ONLY**

(Section III or Section IV must be completed)

Every petition for abatement or refund filed pursuant to § 39-10-114, C.R.S. shall be acted upon pursuant to the provisions of this section by the Board of County Commissioners or the Assessor, as appropriate, within six months of the date of filing such petition, § 39-1-113(1.7), C.R.S.

**Section III: Written Mutual Agreement of Assessor and Petitioner**

(Only for abatements up to \$10,000)

The Commissioners of \_\_\_\_\_ County authorize the Assessor by Resolution No. \_\_\_\_\_ to review petitions for abatement or refund and to settle by written mutual agreement any such petition for abatement or refund in an amount of \$10,000 or less per tract, parcel, or lot of land or per schedule of personal property, in accordance with § 39-1-113(1.5), C.R.S.

**The Assessor and Petitioner mutually agree to the values and tax abatement/refund of:**

	Tax Year _____		
	<u>Actual</u>	<u>Assessed</u>	<u>Tax</u>
Original	_____	_____	_____
Corrected	_____	_____	_____
Abate/Refund	_____	_____	_____

Note: The total tax amount does not include accrued interest, penalties, and fees associated with late and/or delinquent tax payments, if applicable. Please contact the County Treasurer for full payment information.

\_\_\_\_\_  
 Petitioner's Signature Date

\_\_\_\_\_  
 Assessor's or Deputy Assessor's Signature Date

**Section IV: Decision of the County Commissioners**

(Must be completed if Section III does not apply)

WHEREAS, the County Commissioners of \_\_\_\_\_ County, State of Colorado, at a duly and lawfully called regular meeting held on \_\_\_\_/\_\_\_\_/\_\_\_\_, at which meeting there were present the following members:

Month Day Year

with notice of such meeting and an opportunity to be present having been given to the Petitioner and the Assessor of said County and Assessor \_\_\_\_\_ (*being present--not present*) and

Name

Petitioner \_\_\_\_\_ (*being present--not present*), and WHEREAS, the said

Name

County Commissioners have carefully considered the within petition, and are fully advised in relation thereto, NOW BE IT RESOLVED that the Board (*agrees--does not agree*) with the recommendation of the Assessor, and that the petition be (*approved--approved in part--denied*) with an abatement/refund as follows:

Year	Assessed Value	Taxes Abate/Refund
------	----------------	--------------------

\_\_\_\_\_  
 Chairperson of the Board of County Commissioners' Signature

I, \_\_\_\_\_ County Clerk and Ex-Officio Clerk of the Board of County Commissioners in and for the aforementioned county, do hereby certify that the above and foregoing order is truly copied from the record of the proceedings of the Board of County Commissioners.

**IN WITNESS WHEREOF**, I have hereunto set my hand and affixed the seal of said County

this \_\_\_\_\_ day of \_\_\_\_\_, \_\_\_\_\_  
Month Year

\_\_\_\_\_  
 County Clerk's or Deputy County Clerk's Signature

Note: Abatements greater than \$10,000 per schedule, per year, must be submitted in duplicate to the Property Tax Administrator for review.

**Section V: Action of the Property Tax Administrator**

(For all abatements greater than \$10,000)

The action of the Board of County Commissioners, relative to this petition, is hereby

Approved  Approved in part \$ \_\_\_\_\_  Denied for the following reason(s):

\_\_\_\_\_  
 Secretary's Signature Property Tax Administrator's Signature Date

**Ken Musso**  
Assessor



**Assessor's Office**  
4430 South Adams County Parkway  
2nd Floor, Suite C2100  
Brighton, CO 80601-8201  
Phone 720-523-6038  
Fax 720-523-6037  
www.adcogov.org

**BOARD OF COUNTY COMMISSIONERS**

**STIPULATION (As to Tax Year(s) 2018 Actual Value(s))**

1. The property subject to this Stipulation is:  
Schedule No. (S): R0180881 Parcel NO.(S) 0156915302012

2. The subject property is classified as a Commercial property.

3. The County Assessor originally assigned the following actual value to the subject property for tax year(s) 2018 :

Land	\$833,038
Improvements	\$2,661,162
Total	\$3,494,200

4. The Adams County Assessor has reviewed this file and agrees to make the following adjustment to the valuation for the subject property for tax year(s) 2018 :

Land	\$833,038
Improvements	\$2,661,162
Total	\$3,494,200

Classification of property changed from 100% commercial to 66.9%.

5. By entering into this agreement, the Petitioner understands that they are giving up rights to further appeal of the value of this property for tax year(s) 2018.

DATED this: January 14, 2020

Petitioner's Representative  
Sullivan Valuation Services Group, LLC (Agent)  
PO Box 664 Evergreen CO 80437  
303-273-0138

Shannon  
C. Wheeler

Digitally signed by Shannon C. Wheeler  
DN: cn=Shannon C. Wheeler,  
o=Adams County Government,  
ou=Assessor's Office,  
email=swheeler@adcogov.org, c=US  
Date: 2021.01.14 08:53:41 -0700'

Assessor Representative  
Adams County Assessor's Office

**LEGEND**

- LC - LAND COMMERCIAL
- LR LAND RESIDENTIAL
- IC - IMPROVEMENT COMMERCIAL
- IR - IMPROVEMENT RESIDENTIAL

**ASSESSOR'S RECOMMENDATION  
BOARD OF COUNTY COMMISSIONERS (BOCC)**

Account No : R0180881  
 Petition Year : 2018  
 Owner Entity : TRISIMO BRIGHTON II LLC  
 Owner Address : 1910 8TH AVE NE  
 Owner City : ABERDEEN  
 Property Location : 2204 SOUTH MEDICAL CENTER DRIVE - BRIGHTON  
 Parcel No : 0156915302012  
 Date Filed : August 14, 2020  
 State : SD

TYPE	OCC CODE	PETITIONER'S REQUESTED VALUES		ASSESSOR'S ASSIGNED VALUES		ORIGINAL TAX WARRANT	
		Actual Value	Assessed Value	Actual Value	Assessed Value	A. Ratio COM	A. Ratio RES
REAL	1332			LC: \$833,038	\$241,580	29.00%	7.20%
				LR: N/A	\$0		
				IC: \$2,661,162	\$771,740		
				IR: N/A	\$0		
TOTALS :		\$3,494,200	\$1,013,320	\$3,494,200	\$1,013,320		Original Tax \$137,231

**Petitioner's Statement:**

Property reportedly includes residential stays beyond 30 days - thus, a residential rate should be utilized.

**Assessor's Report:**

**Situation :**

Property operates as Candlewood Suites, an extended-stay classified hotel. Petitioner provided DR-100 State of Colorado Documents that illustrated sales against taxed sales as reported by the operator. Claims appears to be inconsistent with prior year.

**Action :**

Reviewed DR-100 documents, which supports claim as indicated above. Processed these figures and an adjustment appears warranted at this time. The claims appeared inconsistent with the prior year. As a result, negotiated similar number to 2017, and these offers were accepted by petitioner.

**Recommendation :**

Upon further review, a classification change appears warranted for the 2018 abatement period.

TYPE	OCC CODE	ASSESSOR'S ASSIGNED VALUE		RECOMMENDED VALUE		REVISED TAX WARRANT	
		Actual Value	Assessed Value	Actual Value	Assessed Value	Tax Refund	Revised Tax
REAL	1332	\$833,038	\$241,580	LC: \$557,301	\$161,620	\$34,146.57	
				LR: N/A	\$0		
				IC: \$2,661,162	\$771,740		
				IR: N/A	\$0		
TOTALS :		\$3,494,200	\$1,013,320	\$3,494,200	\$63,420		\$103,084.32

Shannon Wheeler - Commercial Supervisor  
 Assessor Representative

January 14, 2021  
 Date

2019 Abatement Calculation	
Building Area	
Total of all buildings	41,313
Total of Residential	13,675
Pro Rate Share - Total For Land	33.100%
Building 1 Size	41,313
Residential Portion	13,675
ProRata Share - Residential	33.100%
Pro Rata Share Commercial	66.900%
Land Area Calculation	
Total	66,643.00
Commercial	44,584.17
Residential	22,058.83
Value Calculation	
NEW - Total Value	\$3,494,200
Residential total value	\$1,156,580
Land	\$275,738
Improvements	\$880,843
Commercial total value	\$2,337,620
Land	\$557,301
Improvements	\$1,780,319

**PETITION FOR ABATEMENT OR REFUND OF TAXES**

County: ADAMS

Date Received \_\_\_\_\_  
 (Use Assessor's or Commissioners' Date Stamp)

AUG 14 2020  
 OFFICE OF THE  
 ADAMS COUNTY ASSESSOR

**Section I: Petitioner, please complete Section I only.**

Date: 8 10 2020  
 Month Day Year

Petitioner's Name: TRISIMO BRIGHTON II LLC  
 Petitioner's Mailing Address: Sullivan Valuation Services Group LLC - PO Box 664  
Evergreen Colorado 80437  
 City or Town State Zip Code

SCHEDULE OR PARCEL NUMBER(S)	PROPERTY ADDRESS OR LEGAL DESCRIPTION OF PROPERTY
<u>R0180881</u>	<u>2204 S Medical Center Dr. Brighton CO 80601</u>

Petitioner requests an abatement or refund of the appropriate taxes and states that the taxes assessed against the above property for the property tax year 2018 are incorrect for the following reasons: (Briefly describe why the taxes have been levied erroneously or illegally, whether due to erroneous valuation, irregularity in levying, clerical error, or overvaluation. Attach additional sheets if necessary.)

The petitioner's claim is to correct the property classification to mixed use; and to account for extended stays of greater than 30 days. Residential 60.4% and Commercial 39.6%.

Petitioner's estimate of value: \$ 3,494,200 ( 2018 ) Classification Abatement Appeal  
 Value Year

I declare, under penalty of perjury in the second degree, that this petition, together with any accompanying exhibits or statements, has been prepared or examined by me, and to the best of my knowledge, information, and belief, is true, correct, and complete.

See attached agency authorization

Petitioner's Signature



By \_\_\_\_\_  
 Agent's Signature

Daytime Phone Number ( \_\_\_\_\_ )

Email See attached agency authorization

Daytime Phone Number (303) 273-0138

Printed Name: Patrick Sullivan, Authorized Agent

Email patrick@sullivantax.us

\*Letter of agency must be attached when petition is submitted by an agent.

If the Board of County Commissioners, pursuant to § 39-10-114(1), C.R.S., or the Property Tax Administrator, pursuant to § 39-2-116, C.R.S., denies the petition for refund or abatement of taxes in whole or in part, the Petitioner may appeal to the Board of Assessment Appeals pursuant to the provisions of § 39-2-125, C.R.S., within thirty days of the entry of any such decision, § 39-10-114.5(1), C.R.S.

	Tax Year _____		
	Actual	Assessed	Tax
Original	_____	_____	_____
Corrected	_____	_____	_____
Abate/Refund	_____	_____	_____

Assessor recommends approval as outlined above.

If the request for abatement is based upon the grounds of overvaluation, no abatement or refund of taxes shall be made if an objection or protest to such valuation has been filed and a Notice of Determination has been mailed to the taxpayer, § 39-10-114(1)(a)(i)(D), C.R.S.

Tax year: \_\_\_\_\_ Protest?  No  Yes (If a protest was filed, please attach a copy of the NOD.)

Assessor recommends denial for the following reason(s):

\_\_\_\_\_  
 Assessor's or Deputy Assessor's Signature

R0180881

**FOR ASSESSORS AND COUNTY COMMISSIONERS USE ONLY**  
(Section III or Section IV must be completed)

Every petition for abatement or refund filed pursuant to § 39-10-114, C.R.S. shall be acted upon pursuant to the provisions of this section by the Board of County Commissioners or the Assessor, as appropriate, within six months of the date of filing such petition, § 39-1-113(1.7), C.R.S.

**Section III: Written Mutual Agreement of Assessor and Petitioner**  
(Only for abatements up to \$10,000)

The Commissioners of \_\_\_\_\_ County authorize the Assessor by Resolution No. \_\_\_\_\_ to review petitions for abatement or refund and to settle by written mutual agreement any such petition for abatement or refund in an amount of \$10,000 or less per tract, parcel, or lot of land or per schedule of personal property, in accordance with § 39-1-113(1.5), C.R.S.

The Assessor and Petitioner mutually agree to the values and tax abatement/refund of:

	Tax Year _____		
	Actual	Assessed	Tax
Original	_____	_____	_____
Corrected	_____	_____	_____
Abate/Refund	_____	_____	_____

Note: The total tax amount does not include accrued interest, penalties, and fees associated with late and/or delinquent tax payments, if applicable. Please contact the County Treasurer for full payment information.

\_\_\_\_\_  
 Petitioner's Signature Date

\_\_\_\_\_  
 Assessor's or Deputy Assessor's Signature Date

**Section IV: Decision of the County Commissioners**  
(Must be completed if Section III does not apply)

WHEREAS, the County Commissioners of \_\_\_\_\_ County, State of Colorado, at a duly and lawfully called regular meeting held on \_\_\_\_/\_\_\_\_/\_\_\_\_, at which meeting there were present the following members:

Month Day Year

with notice of such meeting and an opportunity to be present having been given to the Petitioner and the Assessor of said County and Assessor \_\_\_\_\_ (*being present--not present*) and  
Name  
Petitioner \_\_\_\_\_ (*being present--not present*), and WHEREAS, the said  
Name  
County Commissioners have carefully considered the within petition, and are fully advised in relation thereto, NOW BE IT RESOLVED that the Board (*agrees--does not agree*) with the recommendation of the Assessor, and that the petition be (*approved--approved in part--denied*) with an abatement/refund as follows:

Year	Assessed Value	Taxes Abate/Refund

\_\_\_\_\_  
 Chairperson of the Board of County Commissioners' Signature

I, \_\_\_\_\_ County Clerk and Ex-Officio Clerk of the Board of County Commissioners in and for the aforementioned county, do hereby certify that the above and foregoing order is truly copied from the record of the proceedings of the Board of County Commissioners.

IN WITNESS WHEREOF, I have hereunto set my hand and affixed the seal of said County  
this \_\_\_\_\_ day of \_\_\_\_\_,  
Month Year

\_\_\_\_\_  
 County Clerk's or Deputy County Clerk's Signature

Note: Abatements greater than \$10,000 per schedule, per year, must be submitted in duplicate to the Property Tax Administrator for review.

**Section V: Action of the Property Tax Administrator**  
(For all abatements greater than \$10,000)

The action of the Board of County Commissioners, relative to this petition, is hereby  
 Approved  Approved in part \$ \_\_\_\_\_  Denied for the following reason(s):

\_\_\_\_\_  
 Secretary's Signature Property Tax Administrator's Signature Date



## PUBLIC HEARING AGENDA ITEM

<b>DATE OF PUBLIC HEARING:</b> February 23, 2021
<b>SUBJECT:</b> Resolution Regarding Defense and Indemnification of Jonathan Eller as a Defendant Pursuant to C.R.S. § 24-10-101, et seq., 20cv31391
<b>FROM:</b> Heidi Miller, County Attorney, County Attorney and Kerri Booth, Assistant County Attorney
<b>AGENCY/DEPARTMENT:</b> County Attorney's Office
<b>HEARD AT STUDY SESSION ON</b> N/A
<b>AUTHORIZATION TO MOVE FORWARD:</b> <input type="checkbox"/> YES <input type="checkbox"/> NO
<b>RECOMMENDED ACTION:</b> That the Board of County Commissioners Adopt the Resolution Regarding Defense and Indemnification of Jonathan Eller as a Defendant Pursuant to C.R.S. § 24-10-101, et seq.

### **BACKGROUND:**

The Board of County Commissioners formally indemnifies employees and elected officials who are named in civil lawsuits. This lawsuit is brought by Ryan Beyer and Lucas Otero, minor child, who claim they were injured in a car accident when the vehicle Ryan Beyer was driving, and Lucas Otero was a passenger in, collided with a county owned Ford Expedition that was being driven by Jonathan Eller.

The County Attorney's Office has reviewed the facts of this lawsuit and it has been determined that Jonathan Eller was acting within the course and scope of his employment at all relevant times relevant to this lawsuit. Therefore, the County Attorney's Office is recommending that Jonathan Eller be indemnified for any potential damages that might arise out of this litigation.

### **AGENCIES, DEPARTMENTS OR OTHER OFFICES INVOLVED:**

### **ATTACHED DOCUMENTS:**

RESOLUTION REGARDING DEFENSE AND INDEMNIFICATION OF JONATHAN ELLER AS A DEFENDANT PURSUANT TO C.R.S. § 24-10-101, ET SEQ.

**FISCAL IMPACT:**

Please check if there is no fiscal impact . If there is fiscal impact, please fully complete the section below.

<b>Fund:</b>
<b>Cost Center:</b>

	<b>Object Account</b>	<b>Subledger</b>	<b>Amount</b>
Current Budgeted Revenue:			
Additional Revenue not included in Current Budget:			
<b>Total Revenues:</b>			<hr/>

	<b>Object Account</b>	<b>Subledger</b>	<b>Amount</b>
Current Budgeted Operating Expenditure:			
Add'l Operating Expenditure not included in Current Budget:			
Current Budgeted Capital Expenditure:			
Add'l Capital Expenditure not included in Current Budget:			
<b>Total Expenditures:</b>			<hr/> <hr/>

New FTEs requested:             YES             NO

Future Amendment Needed:     YES             NO

**Additional Note:**

Potential fiscal impact is unknown. If litigation results in settlement or judgment against the County or its employees/elected officials, there would be a fiscal impact. The potential amount of that impact is impossible to estimate at this time.

RESOLUTION REGARDING DEFENSE AND INDEMNIFICATION OF JONATHAN ELLER  
AS A DEFENDANT PURSUANT TO C.R.S. § 24-10-101, ET SEQ.

WHEREAS, Adams County is a public entity pursuant to the Colorado Governmental Immunity Act; and,

WHEREAS, Adams County is obligated to bear the cost of the defense of its elected officials and employees and pay all judgments entered against its elected officials and employees pursuant to the Colorado Governmental Immunity Act so long as they acted within the course and scope of their employment and their acts were not willful and wanton; and,

WHEREAS, Jonathan Eller has been sued in the matter of *Ryan Beyer, et al. v. Jonathan Eller, et al.* filed in Adams County District Court with Case Number 20CV31391, with said Defendant being an employee of Adams County at the time of the incident described in the Complaint; and,

WHEREAS, initial investigation has revealed to the satisfaction of the Board of County Commissioners and the determination has been made that the Defendant appears to have acted within the course and scope of his employment and his actions do not appear to be willful and wanton; and,

WHEREAS, pursuant to C.R.S. §§ 24-10-110, 24-10-113, and 24-10-118(5) Adams County hereby determines that it is in the public interest to bear the cost of defense for the Defendant against all asserted claims for compensatory and punitive damages which may be pled and to pay or settle any such compensatory and punitive damage claims against said Defendant; and,

WHEREAS, in exchange for such defense, the Defendant is required to cooperate fully in the defense of this matter, including but not limited to, assisting in the discovery process, participating in mediation, facilitation, or other measures deemed appropriate by the Board of County Commissioners, and Defendant acknowledges that Adams County may settle on behalf of the Defendant any or all asserted claims, including those for personal liability and punitive damages.

NOW, THEREFORE, BE IT RESOLVED, by the Board of County Commissioners of the County of Adams, State of Colorado, that Adams County shall bear the cost of defense for Jonathan Eller against all asserted claims for compensatory and punitive damages which may be pled, and to pay or settle any such compensatory and punitive damage claims against said Defendant, in the matter of *Ryan Beyer, et al. v. Jonathan Eller, et al.*

IT IS FURTHER RESOLVED that the Adams County Attorney is directed to enter her appearance as counsel for Defendant and to defend this matter.







## PUBLIC HEARING AGENDA ITEM

<b>DATE OF PUBLIC HEARING:</b> February 23, 2021
<b>SUBJECT:</b> 2020 External Audit
<b>FROM:</b> Raymond H. Gonzales, County Manager Alisha Reis, Deputy County Manager Nancy Duncan, Budget & Finance Director Jennifer Tierney Hammer, Procurement & Contracts Manager
<b>AGENCY/DEPARTMENT:</b> Finance Department
<b>HEARD AT STUDY SESSION ON:</b> N/A
<b>AUTHORIZATION TO MOVE FORWARD:</b> <input type="checkbox"/> YES <input type="checkbox"/> NO
<b>RECOMMENDED ACTION:</b> That the Board of County Commissioners approves Amendment Two to the agreement with CliftonAllenLarson LLP for the 2020 External Audit.

**BACKGROUND:**

Local Governments including Adams County are required by C.R.S. 29-1-603 to have an annual audit performed on the financial statements. The County's financings also require annual audits as continuing disclosure.

The County's annual audit includes two primary components in the Comprehensive Annual Financial Report (CAFR) and the Financial Section includes the County's Financial Statements. The Compliance Section includes the Single Audit which was conducted in conformity with the provision of the Single Audit Act of 1987, the Single Audit Act Amendments of 1996, and Title 2 U.S. Code of Regulation part 200. The County's audit firm gives opinions related to these items.

In 2016, a formal Request for Proposal was posted on Bidnet and CliftonAllenLarson LLP was awarded a three year agreement with two one-year extensions. The agreement breaks down as follows:

Original Agreement -	Approved December 6, 2016	\$370, 000.00
Amendment One 2019.269	Approved September 5, 2019	\$128,500.00
Amendment Two 2020.327		\$131,000.00
	Total Agreement Amount:	\$629,500.00

The recommendation is to approve Amendment Two for the final extension of the Agreement and Sign the engagement letter with CliftonAllenLarson LLP in the amount of \$131,000.00 for a total not to exceed agreement amount of \$629,500.00.

**AGENCIES, DEPARTMENTS OR OTHER OFFICES INVOLVED:**

Finance Department

**ATTACHED DOCUMENTS:**

Resolution

**FISCAL IMPACT:**

Please check if there is no fiscal impact . If there is fiscal impact, please fully complete the section below.

<b>Fund: 1</b>
<b>Cost Center: 9252</b>

	<b>Object Account</b>	<b>Subledger</b>	<b>Amount</b>
Current Budgeted Revenue:			
Additional Revenue not included in Current Budget:			
<b>Total Revenues:</b>			<u>                    </u>

	<b>Object Account</b>	<b>Subledger</b>	<b>Amount</b>
Current Budgeted Operating Expenditure:	7620		\$130,000.00
Add'l Operating Expenditure not included in Current Budget:			
Current Budgeted Capital Expenditure:			
Add'l Capital Expenditure not included in Current Budget:			
<b>Total Expenditures:</b>			<u>\$130,000.00</u>

**New FTEs requested:**                     YES             NO

**Future Amendment Needed:**         YES             NO

**Additional Note:**

BOARD OF COUNTY COMMISSIONERS FOR  
ADAMS COUNTY, STATE OF COLORADO

RESOLUTION APPROVING AMENDMENT TWO  
TO THE AGREEMENT BETWEEN ADAMS COUNTY AND  
CLIFTONLARSONALLEN, LLP FOR EXTERNAL AUDIT SERVICES

WHEREAS, on December 6, 2016, the Adams County Board of County Commissioners (the "County") approved an Agreement with CliftonLarsonAllen, LLP to provide External Auditing Services (the "Original Agreement"); and,

WHEREAS, the County and CliftonLarsonAllen, LLP approved Amendment One to Original Agreement on September 5, 2019 to amend and extend the external auditing services; and,

WHEREAS, the County and CliftonLarsonAllen, LLP agree to once again amend and extend the Original Agreement for External Auditing Services in the amount of \$131,000.00 for a total not to exceed amount of \$629,500.00.

NOW, THEREFORE, BE IT RESOLVED, by the Board of County Commissioners, County of Adams, State of Colorado, that Amendment Two to the Agreement with CliftonLarsonAllen, LLP to provide External Audit Services is hereby approved.

BE IT FURTHER RESOLVED, that the Chair of the Board of County Commissioners is hereby authorized to sign said Amendment Two to the Agreement with CliftonLarsonAllen, LLP on behalf of Adams County, after negotiation and approval as to form is completed by the County Attorney's Office.



## PUBLIC HEARING AGENDA ITEM

<b>DATE OF PUBLIC HEARING:</b> February 23, 2021
<b>SUBJECT:</b> Countywide Translation and Interpretation Services
<b>FROM:</b> Raymond H. Gonzales, County Manager Alisha Reis, Deputy County Manager Nancy Duncan, Finance & Budget Director Jen Tierney Hammer, Procurement and Contracts Supervisor
<b>AGENCY/DEPARTMENT:</b> All
<b>HEARD AT STUDY SESSION ON:</b> N/A
<b>AUTHORIZATION TO MOVE FORWARD:</b> <input type="checkbox"/> YES <input type="checkbox"/> NO
<b>RECOMMENDED ACTION:</b> That the Board of County Commissioners approves Amendment Three to the agreement with Cesco Linguistic Services Inc., and A&A Languages LLC, to provide Translation and Interpretation Services.

### **BACKGROUND:**

Adams County Government uses the services of qualified linguistic agencies to provide translation and interpretation services, on an “*as needed*” basis. Multiple County Offices and Departments experience individuals with language barriers who are unable to read, write, speak English, or are deaf/hearing impaired. To better assist this population, face-to-face interpretation and translation services are required to support the diverse culture of Adams County’s community who speak various languages at specified locations and often at short notices.

A formal Request for Proposal was solicited through BidNet and agreements were approved by the Board of County Commissioners on August 22, 2017, with Cesco Linguistic Services Inc., and A&A Languages, LLC.

Staff is currently working on a new Request for Proposal for County-Wide Translation Services and would like to extend the current agreements with Cesco Linguistic Services Inc., and A&A Languages, LLC, through June 1, 2021 to allow for the completion of the procurement process.

**A&A Languages LLC:**

<b>Agreement/Amendment</b>	<b>Approval Date</b>	<b>Amount</b>
Original Agreement	Approved September 21, 2017	\$100,000.00
Amendment One- Renewal	Approved October 9, 2018	\$100,000.00
Amendment Two-Additional Funds	Approved November 19, 2019	\$100,000.00
Amendment Time Extension		\$80,000.00
	Total Agreement Amount:	\$380,000.00

**Cesco Linguistic Services Inc.:**

<b>Agreement/Amendment</b>	<b>Approval Date</b>	<b>Amount</b>
Original Agreement	Approved August 29, 2017	\$400,000.00
Amendment One- Renewal	Approved September 11, 2018	\$230,000.00
Amendment Two-Additional Funds	Approved November 19, 2019	\$630,000.00
Amendment Three-Time Extension		\$93,000.00
	Total Agreement Amount:	\$1,353,000.00

The recommendation is to approve Amendment Three to the agreement with Cesco Linguistic Services Inc., in the not to exceed amount of \$93,000.00 and A&A Languages, LLC in the not to exceed amount of \$80,000.00.

**AGENCIES, DEPARTMENTS OR OTHER OFFICES INVOLVED:**

All County Offices and Departments

**ATTACHED DOCUMENTS:**

Resolutions

**FISCAL IMPACT:**

Please check if there is no fiscal impact . If there is fiscal impact, please fully complete the section below.

<b>Fund:</b> varies
<b>Cost Center:</b> varies

	<b>Object Account</b>	<b>Subledger</b>	<b>Amount</b>
Current Budgeted Revenue:			
Additional Revenue not included in Current Budget:			
<b>Total Revenues:</b>			<u>                    </u>

	<b>Object Account</b>	<b>Subledger</b>	<b>Amount</b>
Current Budgeted Operating Expenditure:	7665		\$344,000
Add'l Operating Expenditure not included in Current Budget:			
Current Budgeted Capital Expenditure:			
Add'l Capital Expenditure not included in Current Budget:			
<b>Total Expenditures:</b>			<u>                    </u> \$344,000

**New FTEs requested:**                       YES             NO

**Future Amendment Needed:**             YES             NO

**Additional Note:**

Some Departments and Elected Offices may not budget specifically for translation and Interpretation services, but instead budget for professional services at a higher level.

BOARD OF COUNTY COMMISSIONERS FOR  
ADAMS COUNTY, STATE OF COLORADO

RESOLUTION APPROVING AMENDMENT THREE TO THE AGREEMENT BETWEEN  
ADAMS COUNTY AND CESCO LINGUISTIC SERVICES INC., TO PROVIDE  
TRANSLATION SERVICES FOR ADAMS COUNTY

WHEREAS, the Adams County Board of County Commissioners (the “County”) approved an Agreement for Translation Services with Cesco Linguistic Services Inc., in August of 2017 (the “Original Agreement”); and,

WHEREAS, the Original Agreement was amended by Amendment One and Amendment to the Original Agreement in September of 2018 and November of 2019, respectively; and,

WHEREAS, Adams County would like to once again amend and extend the Original Agreement until June 1, 2021 by the terms and conditions of said Amendment Three to the Agreement with Cesco Linguistic Services Inc.; and,

WHEREAS, Cesco Linguistic Services Inc., agrees to provide the services in the not to exceed amount of \$93,000.00 for a total not to exceed agreement amount of \$1,353,000.00.

NOW, THEREFORE, BE IT RESOLVED, by the Board of County Commissioners, County of Adams, State of Colorado, that said Amendment Three to the Agreement with Cesco Linguistic Services Inc., is hereby approved.

BE IT FURTHER RESOLVED, that the Chair of the Board of County Commissioners is hereby authorized to sign said Amendment Three with Cesco Linguistic Services Inc., after negotiation and approval as to form is completed by the Adams County Attorney's Office.





## PUBLIC HEARING AGENDA ITEM

<b>DATE OF PUBLIC HEARING:</b> February 23, 2021
<b>SUBJECT:</b> Countywide Translation and Interpretation Services
<b>FROM:</b> Raymond H. Gonzales, County Manager Alisha Reis, Deputy County Manager Nancy Duncan, Finance & Budget Director Jen Tierney Hammer, Procurement and Contracts Supervisor
<b>AGENCY/DEPARTMENT:</b> All
<b>HEARD AT STUDY SESSION ON:</b> N/A
<b>AUTHORIZATION TO MOVE FORWARD:</b> <input type="checkbox"/> YES <input type="checkbox"/> NO
<b>RECOMMENDED ACTION:</b> That the Board of County Commissioners approves Amendment Three to the agreement with Cesco Linguistic Services Inc., and A&A Languages LLC, to provide Translation and Interpretation Services.

### **BACKGROUND:**

Adams County Government uses the services of qualified linguistic agencies to provide translation and interpretation services, on an “*as needed*” basis. Multiple County Offices and Departments experience individuals with language barriers who are unable to read, write, speak English, or are deaf/hearing impaired. To better assist this population, face-to-face interpretation and translation services are required to support the diverse culture of Adams County’s community who speak various languages at specified locations and often at short notices.

A formal Request for Proposal was solicited through BidNet and agreements were approved by the Board of County Commissioners on August 22, 2017, with Cesco Linguistic Services Inc., and A&A Languages, LLC.

Staff is currently working on a new Request for Proposal for County-Wide Translation Services and would like to extend the current agreements with Cesco Linguistic Services Inc., and A&A Languages, LLC, through June 1, 2021 to allow for the completion of the procurement process.

**A&A Languages, LLC:**

<b>Agreement/Amendment</b>	<b>Approval Date</b>	<b>Amount</b>
Original Agreement	Approved September 21, 2017	\$100,000.00
Amendment One- Renewal	Approved October 9, 2018	\$100,000.00
Amendment Two-Additional Funds	Approved November 19, 2019	\$100,000.00
Amendment Time Extension		\$80,000.00
	Total Agreement Amount:	\$380,000.00

**Cesco Linguistic Services Inc.,**

<b>Agreement/Amendment</b>	<b>Approval Date</b>	<b>Amount</b>
Original Agreement	Approved August 29, 2017	\$400,000.00
Amendment One- Renewal	Approved September 11, 2018	\$230,000.00
Amendment Two-Additional Funds	Approved November 19, 2019	\$630,000.00
Amendment Three-Time Extension		\$93,000.00
	Total Agreement Amount:	\$1,353,000.00

The recommendation is to approve Amendment Three to the agreement with Cesco Linguistic Services Inc., in the not to exceed amount of \$93,000.00 and A&A Languages, LLC in the not to exceed amount of \$80,000.00.

**AGENCIES, DEPARTMENTS OR OTHER OFFICES INVOLVED:**

All County Offices and Departments

**ATTACHED DOCUMENTS:**

Resolutions

**FISCAL IMPACT:**

Please check if there is no fiscal impact . If there is fiscal impact, please fully complete the section below.

<b>Fund:</b> varies
<b>Cost Center:</b> varies

	<b>Object Account</b>	<b>Subledger</b>	<b>Amount</b>
Current Budgeted Revenue:			
Additional Revenue not included in Current Budget:			
<b>Total Revenues:</b>			<hr/> <hr/>

	<b>Object Account</b>	<b>Subledger</b>	<b>Amount</b>
Current Budgeted Operating Expenditure:	7665		\$344,000
Add'l Operating Expenditure not included in Current Budget:			
Current Budgeted Capital Expenditure:			
Add'l Capital Expenditure not included in Current Budget:			
<b>Total Expenditures:</b>			<hr/> <hr/> \$344,000

**New FTEs requested:**                     YES             NO

**Future Amendment Needed:**             YES             NO

**Additional Note:**

Some Departments and Elected Offices may not budget specifically for translation and Interpretation services, but instead budget for professional services at a higher level.

BOARD OF COUNTY COMMISSIONERS FOR  
ADAMS COUNTY, STATE OF COLORADO

RESOLUTION APPROVING AMENDMENT THREE TO THE AGREEMENT BETWEEN  
ADAMS COUNTY AND A&A LANGUAGES, LLC, FOR TRANSLATION SERVICES

WHEREAS, the Board of County Commissioners approved the Agreement between Adams County and A&A Languages, LLC for Translation Services on September 21, 2017 (the “Original Agreement”); and,

WHEREAS, Adams County has amended and extended the Original Agreement by Amendment One and Amendment Two to said agreement on October 9, 2018 and November 19, 2019, respectively; and,

WHEREAS, Adams County would like to once again extend the Original Agreement through June 1, 2021; and,

WHEREAS, A&A Languages, LLC, agrees to provide the services in the not to exceed amount of \$80,000.00 for a total not to exceed agreement amount of \$380,000.00.

NOW, THEREFORE, BE IT RESOLVED, by the Board of County Commissioners, County of Adams, State of Colorado, that Amendment Three to the Agreement between Adams County and A&A Languages, LLC for Translation Services, is hereby approved.

BE IT FURTHER RESOLVED, that the Chair of the Board of County Commissioners is hereby authorized to sign said Amendment Three after negotiation and approval as to form is completed by the County Attorney's Office.



## PUBLIC HEARING AGENDA ITEM

<b>DATE OF PUBLIC HEARING:</b> February 23, 2021
<b>SUBJECT:</b> Rehabilitation of 96 <sup>th</sup> Avenue Bridge over Bijou Creek Phase Two
<b>FROM:</b> Raymond H. Gonzales, County Manager Alisha Reis, Deputy County Manager Nancy Duncan, Budget & Finance Director Jennifer Tierney Hammer, Procurement & Contracts Manager
<b>AGENCY/DEPARTMENT:</b> Public Works Department
<b>HEARD AT STUDY SESSION ON:</b> N/A
<b>AUTHORIZATION TO MOVE FORWARD:</b> <input type="checkbox"/> YES <input type="checkbox"/> NO
<b>RECOMMENDED ACTION:</b> That the Board of County Commissioners approves an Agreement with Meyers & Sons Construction, LLC, for the Rehabilitation of 96 <sup>th</sup> Avenue Bridge over Bijou Creek Phase Two project.

**BACKGROUND:**

The Adams County Public Works Department determined the need for construction services to rehabilitate the structural condition of the existing 96<sup>th</sup> Avenue bridge over Bijou Creek in eastern Adams County. A Phase One project to rehabilitate the bridge substructure and approach roadway was completed in 2020. The Phase Two project will rehabilitate the superstructure and complete the overall bridge work. This project continues the County’s efforts for improvements to the bridge inventory.

A formal IFB was posted on BidNet. Bids were received on January 28, 2021, from the following responsive companies:

Company Name	Total Bid
Meyers & Sons Construction	\$546,731.75
Structures, Inc.	\$714,036.00
Jalisco International, Inc.	\$719,347.00
Hallmark, Inc.	\$792,484.00
ABCO Contracting, Inc.	\$796,742.00
Mountain Constructors, Inc.	\$938,475.00

After review, it was determined that Meyers & Sons Construction, LLC, was the lowest, responsive and responsible bidder. The recommendation is to award an Agreement to Meyers & Sons Construction, LLC, for the Rehabilitation of 96<sup>th</sup> Avenue Bridge over Bijou Creek Phase 2 project for a total not to exceed amount of \$546,731.75.

**AGENCIES, DEPARTMENTS OR OTHER OFFICES INVOLVED:**

Public Works Department

**ATTACHED DOCUMENTS:**

Resolution

**FISCAL IMPACT:**

Please check if there is no fiscal impact . If there is fiscal impact, please fully complete the section below.

<b>Fund:</b> 13
<b>Cost Center:</b> 3032

	<b>Object Account</b>	<b>Subledger</b>	<b>Amount</b>
Current Budgeted Revenue:			
Additional Revenue not included in Current Budget:			
<b>Total Revenues:</b>			

	<b>Object Account</b>	<b>Subledger</b>	<b>Amount</b>
Current Budgeted Operating Expenditure:	7820		\$1,400,000
Add'l Operating Expenditure not included in Current Budget:			
Current Budgeted Capital Expenditure:			
Add'l Capital Expenditure not included in Current Budget:			
<b>Total Expenditures:</b>			<u>\$1,400,000</u>

**New FTEs requested:**       YES       NO

**Future Amendment Needed:**       YES       NO

**Additional Note:**

BOARD OF COUNTY COMMISSIONERS FOR  
ADAMS COUNTY, STATE OF COLORADO

RESOLUTION APPROVING AN AGREEMENT BETWEEN ADAMS COUNTY AND  
MEYERS & SONS CONSTRUCTION, LLC, TO PROVIDE CONSTRUCTION SERVICES  
FOR THE 96<sup>TH</sup> AVENUE BRIDGE OVER BIJOU CREEK PHASE TWO PROJECT

WHEREAS, Meyers & Sons Construction, LLC, submitted a bid on January 28, 2021, to provide construction services for the 96<sup>th</sup> Avenue Bridge over Bijou Creek Phase Two project; and,

WHEREAS, Meyers & Sons Construction, LLC was the lowest, responsive, and responsible bidder; and,

WHEREAS, Meyers & Sons Construction, LLC, agrees to provide construction services for the 96<sup>th</sup> Avenue Bridge over Bijou Creek Phase Two project in the not to exceed amount of \$546,731.75.

NOW, THEREFORE, BE IT RESOLVED, by the Board of County Commissioners, County of Adams, State of Colorado, that the Agreement to Meyers & Sons Construction, LLC to Provide Construction Services for the 96<sup>th</sup> Avenue Bridge over Bijou Creek Phase Two Project is hereby approved.

BE IT FURTHER RESOLVED that the Chair of the Board of County Commissioners is hereby authorized to sign said Agreement with Meyers & Sons Construction, LLC, on behalf of Adams County, after negotiation and approval as to form is completed by the County Attorney's Office.



COMMUNITY AND ECONOMIC DEVELOPMENT  
DEPARTMENT

CASE NO.: RCU2020-00026  
CASE NAME: BURKE REZONE

**TABLE OF CONTENTS**

**EXHIBIT 1 – BOCC Staff Report**

**EXHIBIT 2- Maps**

- 2.1 Aerial Map
- 2.2 Zoning Map
- 2.3 Future Land Use Map

**EXHIBIT 3- Applicant Information**

- 3.1 Applicant Written Explanation
- 3.2 Applicant Site Plan

**EXHIBIT 4- Referral Comments**

- 4.1 Referral Comments (Adams County Staff)
- 4.2 Referral Comments (Adams County Fire)
- 4.3 Referral Comments (Adams County Sheriff)
- 4.4 Referral Comments (CDOT)
- 4.5 Referral Comments (Denver Water)
- 4.6 Referral Comments (North Pecos Water & Sanitation District)
- 4.7 Referral Comments (RTD)
- 4.8 Referral Comments (Tri-County Health)
- 4.9 Referral Comments (Xcel Energy)

**EXHIBIT 5- Citizen Comments**

- 5.1 Public Comments (Denison)
- 5.2 Public Comments (Martinez)
- 5.2 Public Comments (Trujillo)

**EXHIBIT 6- Associated Case Materials**

- 6.1 Requests for Comments
- 6.2 Public Hearing Notice
- 6.3 Newspaper Publication
- 6.4 Referral Agency Labels
- 6.5 Property Owner Labels
- 6.6 Certificate of Posting





**COMMUNITY AND ECONOMIC DEVELOPMENT  
DEPARTMENT  
STAFF REPORT**

**Board of County Commissioners**

**February 23, 2021**

<b>CASE No.: RCU2020-00026</b>	<b>CASE NAME: Burke Rezone</b>
Owner & Applicant's Name: Jiejun Burke	
Applicant's Address:	14634 W. 62 <sup>nd</sup> Place, Arvada, CO 80004
Location of Request:	2525 W. 65 <sup>th</sup> Place
Nature of Request:	Rezone from Residential-2 (R-2) to Residential-3 (R-3)
Zone District:	Residential-2 (R-2)
Future Land Use:	Urban Residential
Site Size:	0.41 ac. (17,860 sq. ft.)
Proposed Uses:	Multi-Family Residential (triplex)
Existing Use:	Two-Family Residential (duplex)
Hearing Date(s):	<b>PC: January 28, 2021/ 6:00 pm</b> <b>BoCC: February 23, 2021/ 9:30 am</b>
Report Date:	January 21, 2021
Case Manager:	Greg Barnes
PC Recommendation:	APPROVAL with 4 Findings-of-Fact

**SUMMARY OF APPLICATION**

**Background**

Jiejun Burke, the applicant, owns the property at 2525 West 65<sup>th</sup> Place. The lot is currently designated with Residential-2 (R-2) zoning, which allows for single-family and two-family (duplex) dwellings. The subject property is located within the North Lawn Gardens Subdivision, which was created in 1925. Historically, the property was used for a single-family residence until 2018 when it was converted into a duplex.

The applicant wishes to convert the duplex structure into a multi-family residential use and has filed an application to rezone the lot to Residential-3 (R-3). The proposed conversion to a multi-family residential structure (triplex - three dwelling units) does not expand the existing footprint of the structure. The proposed additional unit would be upstairs from the dwelling constructed in 2018.

**Development Standards and Regulations**

Residential-3 (R-3) is the proposed zone district designation for the subject property. This zone district is intended to serve multi-family residential uses at a density no greater than 14 dwelling units per acre. The Residential-3 zone district requires a minimum lot size of 7,500 square feet to construct a triplex. The subject property exceeds this requirement. Based on the lot configuration, the subject property could yield up to five dwelling units if the rezoning is approved. The applicant has indicated that she is only pursuing three dwelling units. Section 3-15-07 of the County’s Development Standards and Regulations requires a 150-foot minimum lot width within the R-3 zone district. Lot width is measured at the minimum front setback line of the property. The applicant’s proposal for a 76-foot minimum lot width is less than allowed in the proposed zone district, however in December 2020, the Board of Adjustment approved a variance application to allow the 76-foot width in the Residential-3 zone district. The variance was approved based on the lot’s depth-to-width ratio, which has a legally nonconforming condition exceeding today’s maximum standard.

**Site Characteristics**

The subject property is located along the northern side of West 65<sup>th</sup> Place. The site is approximately 18,000 square feet in area. The lot width is 76 feet. The lot depth is 237 feet. The site has a depth-to-width ratio greater than 3:1, which is the maximum allowed by Adams County Subdivision Design Standards. The property was created in 1925, and the depth-to-width ratio is a legally nonconforming condition of the property.

Historically, the site was developed with a single-family dwelling. In 2018, a building permit was approved to construct an addition to the existing home to convert the structure into a duplex. Each dwelling is separated by an attached garage, and the newly constructed unit is on the northern side of the structure, which is also farther from West 65<sup>th</sup> Place.

The applicant’s property is accessed from West 65<sup>th</sup> Place, which is a paved local collector roadway. An existing, two-family dwelling is located on the property, which is planned to remain. The applicant is proposing to add a new dwelling unit within the existing living space of the northernmost dwelling unit. The proposal for three dwellings is not expected to change the outer appearance of the structure or expand the structure’s footprint.

**Surrounding Zoning Designations and Existing Use Activity:**

<b><u>Northwest</u></b> R-2 Single-Family Dwelling	<b><u>North</u></b> R-2 Single-Family Dwelling	<b><u>Northeast</u></b> R-2 Single-Family Dwelling
<b><u>West</u></b> R-2 Place of Worship	<b><u>Subject Property</u></b> R-2 Two-Family Dwelling	<b><u>East</u></b> R-2 Two-Family Dwelling
<b><u>Southwest</u></b> R-2 Single-Family Dwelling	<b><u>South</u></b> R-3 Multi-Family Dwelling	<b><u>Southeast</u></b> R-2 Single-Family Dwelling

**Compatibility with the Surrounding Land Uses**

The subject property is surrounded by single-family, two-family, and multi-family dwellings. The street on which the site is located, West 65<sup>th</sup> Place, consists of all types of dwellings. The larger vicinity within the neighborhood also includes a variety of housing types ranging from single-family, two-family, and limited multi-family dwellings. The street also has several places of worship.

**Future Land Use Designation/Comprehensive Plan**

The future land use designation on the property is Urban Residential. Per Chapter 5 of the County’s Comprehensive Plan, the purpose of the Urban Residential future land use designation is to provide a mix of housing types at residential densities greater than one dwelling unit per acre. The Adams County Balanced Housing Plan’s goals are to improve and support housing opportunities for all residents in Adams County, foster an environment that promotes balanced housing, and integrate development practices that increase diversity in housing stock. The proposed use of the property as a multi-family residential structure containing three dwellings is consistent with the future land use designation, and the proposed rezoning promotes the goals of the Balanced Housing Plan.

**PLANNING COMMISSION UPDATE**

The Planning Commission (PC) considered this case on January 28, 2021 and voted (7-0) to recommend approval of the request. The applicant spoke at the hearing and had no concerns with the staff report or presentation. She stated that her intention is to utilize the property as a triplex. There were no public comments provided at the hearing.

**Staff Recommendation:**

**Based upon the application, the criteria for a rezoning approval, and a recent site visit, staff recommends Approval of this request with 4 findings-of-fact:**

**RECOMMENDED FINDINGS OF FACT REZONING**

1. The Zoning Map amendment is consistent with the Adams County Comprehensive Plan.
2. The Zoning Map amendment is consistent with the purposes of these standards and regulations.
3. The Zoning Map amendment will comply with the requirements of these standards and regulations.
4. The Zoning Map amendment is compatible with the surrounding area, harmonious with the character of the neighborhood, not detrimental to the immediate area, not detrimental to the future development of the area, and not detrimental to the health, safety, or welfare of the inhabitants of the area and the County.

**CITIZEN COMMENTS**

Number of Notices Mailed	Number of Comments Received
269	3

All property owners and occupants within 1,000 feet of the subject property were notified of this request on September 24, 2020. As of writing this report, staff has received three comments regarding the applications for variance and rezoning. One letter was supportive of the request to rezone the

property and two comments were opposed to the request to rezone the property. The letter of support indicated that additional housing would serve the community. The letters of opposition cited that excessive traffic and density were undesirable for the area.

### **COUNTY AGENCY COMMENTS**

Staff reviewed the request and had no concerns that the application met the criteria for approval of a rezoning. The subject property conforms to the County's Development Standards for the residential-3 zone district. The County's Comprehensive Plan and Balanced Housing Plan support the addition of a variety of housing types, including triplexes.

### **REFERRAL AGENCY COMMENTS**

During the referral period, only one referral agency filed any objection to the rezoning request. The Adams County Sheriff was opposed to increased density without additional funding for an increase service. No other agencies raised concern or objection.

#### **Responding with Concerns:**

Adams County Sheriff

#### **Responding without Concerns:**

Adams County Fire District  
Colorado Department of Transportation  
Denver Water  
North Pecos Water & Sanitation District  
Regional Transportation District (RTD)  
Tri-County Health Department (TCHD)  
Xcel Energy

#### **Notified but not Responding / Considered a Favorable Response:**

Arvada Fire District  
Berkeley Neighborhood Association  
Berkeley Sanitation District  
CDPHE  
Century Link  
City of Arvada  
City of Westminster  
Colorado Division of Parks & Wildlife  
Comcast  
Crestview Water & Sanitation District  
Goat Hill Association  
Mapleton School District #1  
Metro Wastewater  
Mobile Gardens Association  
North Lincoln Water & Sanitation District  
North Washington Water & Sanitation District  
Northridge Estates at Gold Run HOA  
Pecos Logistics Park Metropolitan District

Perl Mack Neighborhood Association  
Pomponio Terrace Metropolitan District  
The TOD Group  
Union Pacific Railroad  
Welby Citizen Group  
Westminster Fire District  
Westminster School District #50



**Legend**

- Address
- Highways
  - Interstate
  - Highway
  - Tollway
- Streets
  - Streets
  - Ramp
- Building
- County Parks and Open Space
- Small Lakes
- Major Lakes
- Rivers
  - Canal
  - Ditch
  - Primary Creek
  - River
  - Secondary Creek
  - Stream
- Parcels
- County Boundary

1: 2,141

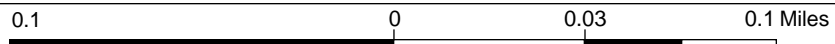

**Notes**

This map is a user generated static output from an Internet mapping site and is for reference only. Data layers that appear on this map may or may not be accurate, current, or otherwise reliable. THIS MAP IS NOT TO BE USED FOR NAVIGATION



Legend

- Address
- Highways
  - Interstate
  - Highway
  - Tollway
- Streets
  - Streets
  - Ramp
- Building
- County Parks and Open Space
- Small Lakes
- Major Lakes
- Rivers
  - Canal
  - Ditch
  - Primary Creek
  - River
  - Secondary Creek
  - Stream
- Parcels
- Zoning
  - Municipality
  - A-1
  - A-2
  - A-3
  - AV
  - C-0
  - C-1
  - C-2
  - C-3

1: 2,141

0.1 0 0.03 0.1 Miles

This map is a user generated static output from an Internet mapping site and is for reference only. Data layers that appear on this map may or may not be accurate, current, or otherwise reliable. THIS MAP IS NOT TO BE USED FOR NAVIGATION

Notes

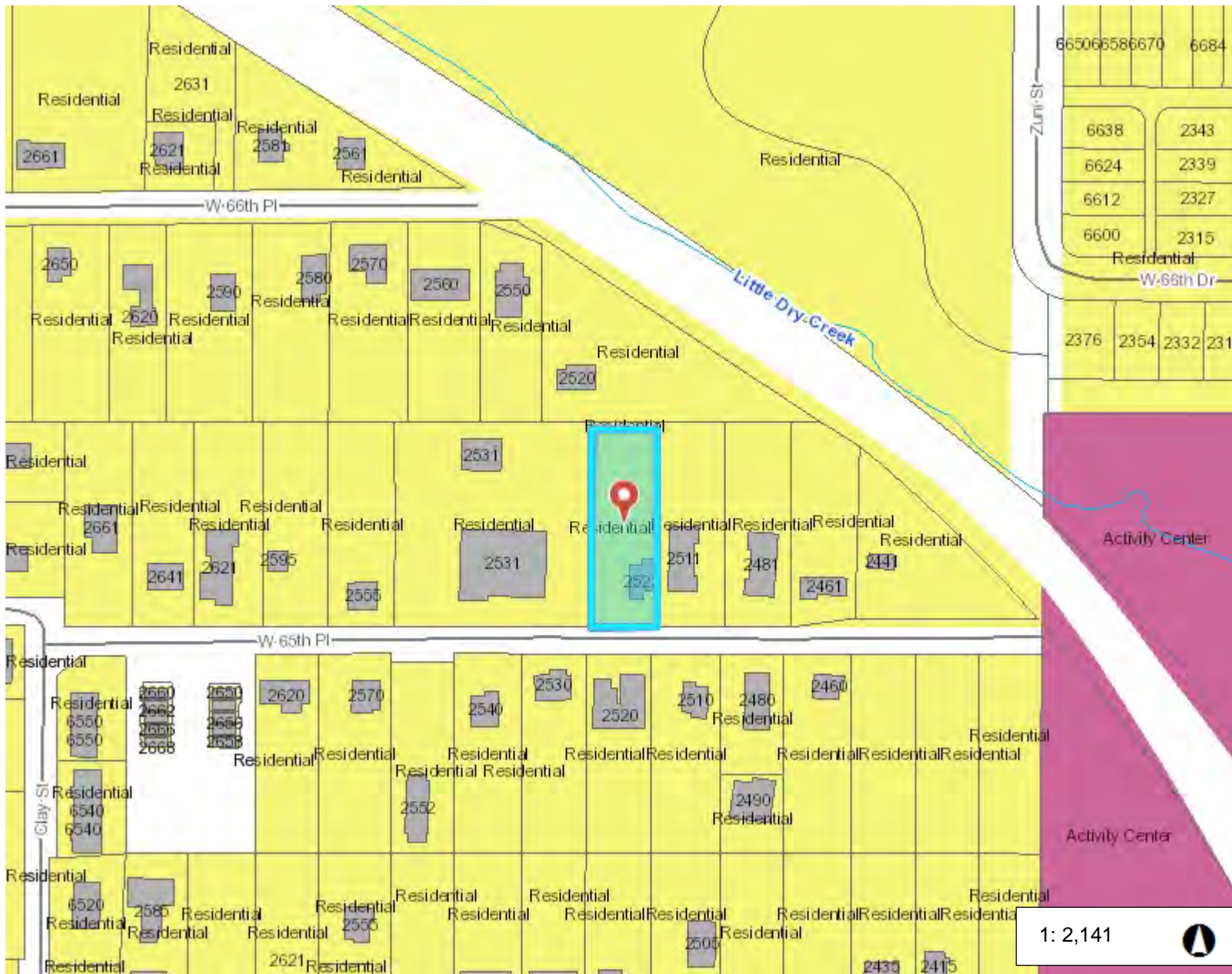

### Legend

- Address**
- Highways**
  - Interstate
  - Highway
  - Tollway
- Streets**
  - Streets
  - Ramp
- Building**
- County Parks and Open Space**
- Small Lakes**
- Major Lakes**
- Rivers**
  - Canal
  - Ditch
  - Primary Creek
  - River
  - Secondary Creek
  - Stream
- Parcels**
- Comprehensive Plan**
  - Urban Residential
  - Estate Residential
  - Local District Mixed Use
  - Mixed Use Neighborhood
  - Activity Center
  - Mixed Use Employment
  - Commercial
  - Industrial
  - Agriculture

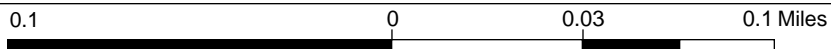

This map is a user generated static output from an Internet mapping site and is for reference only. Data layers that appear on this map may or may not be accurate, current, or otherwise reliable. THIS MAP IS NOT TO BE USED FOR NAVIGATION

Notes



# Explanation of Project

9/7/2020

**Property Location:** 2525 W. 65th Pl, Denver, CO 80221

To whom it may concern,

This property is currently zoned as R2. I'd like to get the property rezoned as R3, allowing for use of the property as a triplex.

This property was recently expanded to include a structure that has the potential to house two families. The main floor of the new structure is currently occupied. The second floor (garden level basement) is unfinished. I'd like to finish this part of the structure, making the property a triplex.

The **Site Plan** describes the property as it exists currently with the addition of where we propose 3rd tennet parking. The site is fully developed and we are not proposing any external changes, unless the county feels they're required for our rezoning application.

Respectfully,

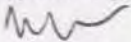

Jiejun Burke

(SUB: NORTH LAWN GARDENS DESC: LOT 23 EXC N 20 FT FOR RD BLK 1)

NORTH

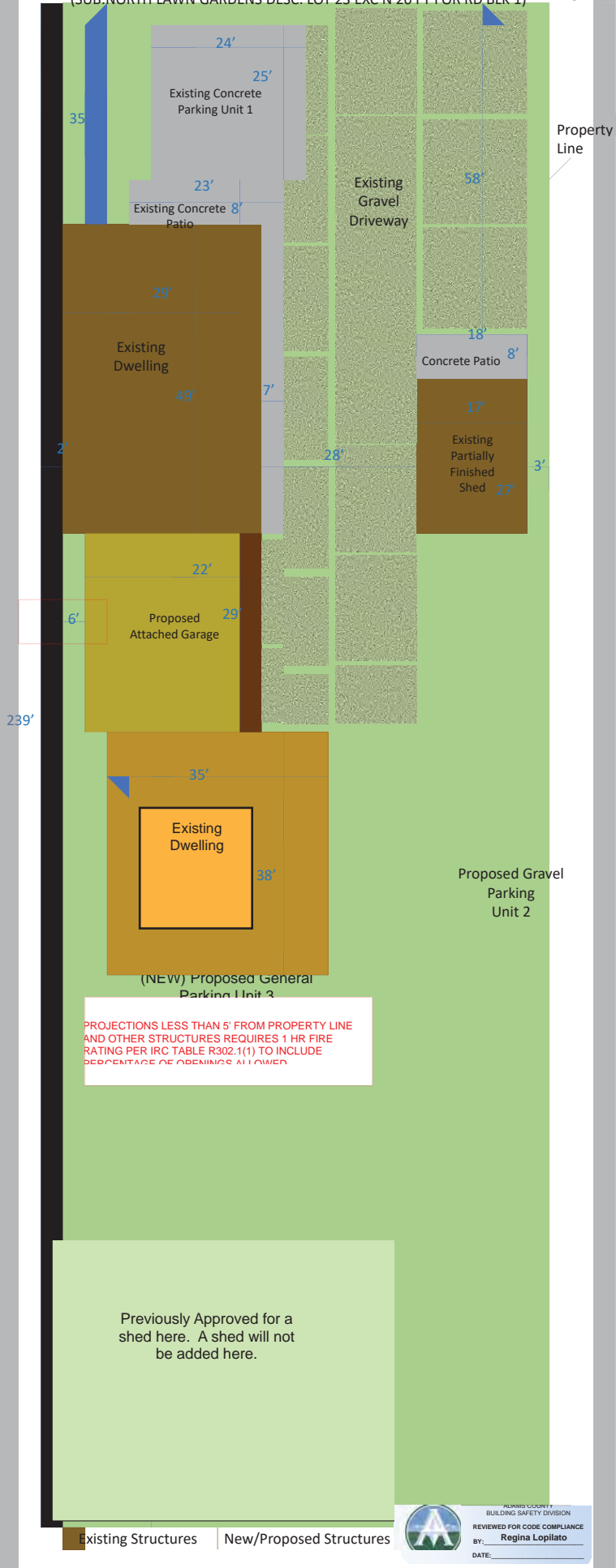

PROJECTIONS LESS THAN 5' FROM PROPERTY LINE AND OTHER STRUCTURES REQUIRES 1 HR FIRE RATING PER IRC TABLE R302.1(1) TO INCLUDE PERCENTAGE OF OPENINGS ALLOWED

Previously Approved for a shed here. A shed will not be added here.

Existing Structures | New/Proposed Structures

ALDEN COUNTY  
BUILDING SAFETY DIVISION  
REVIEWED FOR CODE COMPLIANCE  
BY: **Regina Lopillato**  
DATE: \_\_\_\_\_



## **Development Review Team Comments**

**Date:** 10/23/2020

**Project Number:** RCU2020-00026

**Project Name:** Burke Rezoning at 2525 W. 65th Place

---

**Commenting Division:** Planner Review

**Name of Reviewer:** Greg Barnes

**Date:** 10/16/2020

**Email:** [gjbarnes@adcogov.org](mailto:gjbarnes@adcogov.org)

### **Resubmittal Required**

PLN01: the request is to rezone the subject property at 2525 W 65th Place from Residential-2 to Residential-3. Rezoning applications are expected to conform to the criteria for approval found in Section 2-02-15-06-02 of the Adams County Development Standards & Regulations (DSR).

PLN02: The subject property is approximately 18,000 square feet (0.41 acres) in area, and has a lot width of approximately 77 feet. The associated site plan with this request shows that the proposed development will have attached dwellings. The minimum lot size for Residential-3 zoning is 9,500 square feet per three dwellings. The minimum lot width per is 150 feet for dwellings on a common lot, but only 25 feet per dwelling when lots are subdivided. Based on this information, the application may not conform to the minimum zone district standards unless a variance is obtained.

PLN03: The Adams County Comprehensive Plan has designated a future land use of urban residential for the property. This designation supports residential uses at urban densities.

PLN04: The existing use is largely surrounded single-family homes and duplexes. The property directly to the south is zoned Residential-3. This property has three dwelling units, is similar in size to the subject property, and was approved by the BoCC in 2005.

---

**Commenting Division:** ROW Review

**Name of Reviewer:** Greg Labrie

**Date:** 10/15/2020

**Email:** glabrie@adcogov.org

**Complete**

ROW1: A title commitment should be secured in conjunction with the construction of any proposed new buildings on this property. This will ensure that the proposed building structures on the site does not encroach on another party's rights. A copy should be sent to Adams County to facilitate review.

ROW2: 65th Place is classified as a local street per the 2012 Adams County Master Transportation Plan. As such it should have a half right-of-way width of 25 feet. Since the existing half right-of-way width is 15 feet, this would require a dedication of 10 feet additional right-of-way when new development is initiated on the site.

---

**Commenting Division:** Development Engineering Review

**Name of Reviewer:** Greg Labrie

**Date:** 10/15/2020

**Email:** glabrie@adcogov.org

**Complete**

The following engineering documentation and information will be required to complete the Rezoning Process. Detailed engineering design and analysis will be required at the time of building permits and construction.

ENG1; The applicant is expected to submit a trip generation analysis and a preliminary drainage analysis for the proposed development of the site. The preliminary drainage analysis shall include the use of Adams County engineering standards for the full build out of the site to provide if required a rough estimate of the size and location of the proposed drainage facilities for the site. The analysis shall also include the proposed location of the outfall and identify any stormwater challenges that must be resolved before final construction plans are submitted.

ENG2: Flood Insurance Rate Map – FIRM Panel # (08001C0584H), Federal Emergency Management Agency, January 20, 2016. According to the above reference, the project site is NOT located within a delineated 100-year flood hazard zone; A floodplain use permit will not be required.

ENG3: The project site is not located in a NRCO district. An environmental assessment is not required.

ENG4: The applicant shall be responsible to ensure compliance with all Federal, State, and Local water quality construction requirements. The project site is within the County's MS4 Stormwater Permit area. In the event that the disturbed area of the site exceeds 1 acre the applicant shall be responsible to prepare the SWMP plan using the Adams County ESC Template, and obtain both a County SWQ Permit and State Permit COR-040000.

ENG5: The developer will be required to construct roadway improvements adjacent to the site along 65th Place. Roadway improvements will consist of curb, gutter and sidewalk adjacent to the site and any street improvements as required.

ENG6: If off- site fill material is required to support the grading plan, the applicant is required to obtain a special use permit from Adams County One Stop Permit Center for the offsite fill material. The fill source and quantity are required to be indicated on the drawings and it shall include the source and quantity of selected off-site material.

## Greg Barnes

---

**From:** Carla Gutierrez <cgutierrez@acfpd.org>  
**Sent:** Friday, October 30, 2020 1:46 PM  
**To:** Greg Barnes  
**Subject:** Re: For Review: Burke Variance (VSP2020-00027)

Please be cautious: This email was sent from outside Adams County

Good afternoon Greg,

At this time, the Fire District has no comments or concerns in regards to this variance.

Thank you!

*Carla Gutierrez*

Adams County Fire Rescue  
7980 Elmwood Lane  
Denver, CO 80221  
O: 303-539-6862

---

**From:** Greg Barnes <GJBarnes@adcogov.org>  
**Date:** Friday, October 30, 2020 at 1:28 PM  
**To:** Greg Barnes <GJBarnes@adcogov.org>  
**Subject:** For Review: Burke Variance (VSP2020-00027)

The Adams County Board of Adjustment is requesting comments on the following application:

**Variance to allow a property with 76 feet of lot width to be zoned Residential-3 where a minimum of 150 feet of lot width is required. The case is associated with a rezoning application to change the zone designation on the property from Residential-2 to Residential-3 (RCU2020-00026).**

This request is located at 2525 W 65th Place. The Assessor's Parcel Number is 0182505404027

Owner Information: JIEJUN BURKE, 2525 W 65TH PL, DENVER, CO 80221

Please forward any written comments on this application to the Community and Economic Development Department at 4430 South Adams County Parkway, Suite W2000A Brighton, CO 80601-8216 or call (720) 523-6800 by November 19, 2020 in order that your comments may be taken into consideration in the review of this case. If you would like your comments included verbatim please send your response by way of e-mail to [GJBarnes@adcogov.org](mailto:GJBarnes@adcogov.org).

Once comments have been received and the staff report written, the staff report will be forwarded to you. The full text of the proposed request and additional colored maps can be obtained by contacting this office or by accessing the Adams County web site at [www.adcogov.org/planning/currentcases](http://www.adcogov.org/planning/currentcases). It may take a few business days for the case material to be posted to our website. Thank you for your review of this case.

## Greg Barnes

---

**From:** Rick Reigenborn  
**Sent:** Monday, September 28, 2020 2:16 PM  
**To:** Greg Barnes  
**Subject:** RE: For Review: Burke Rezoning (RCU2020-00026)

I would oppose the change of zoning. The Sheriff's Office could need additional staffing if this and other zoning request are passed.



**Richard A. Reigenborn**  
Sheriff  
**Adams County Sheriff's Office**  
4430 S. Adams County Parkway,  
1<sup>st</sup> Floor, Suite W5400  
Brighton, CO 80601  
303-655-3218 | [RReigenborn@adcogov.org](mailto:RReigenborn@adcogov.org)

*Character • Integrity • Transparency*

---

**From:** Greg Barnes  
**Sent:** Thursday, September 24, 2020 2:52 PM  
**To:** Greg Barnes <[GJBarnes@adcogov.org](mailto:GJBarnes@adcogov.org)>  
**Subject:** For Review: Burke Rezoning (RCU2020-00026)

The Adams County Planning Commission is requesting comments on the following application: **Zoning map amendment (re-zoning) to change the zoning designation from Residential-2 (R-2) to Residential-3 (R-3)**. This request is located at 2525 W 65th Place. The Assessor's Parcel Number is 0182505404027.

Applicant Information:  
JIEJUN BURKE  
2525 W. 65TH PL  
DENVER, CO 80221

Please forward any written comments on this application to the Community and Economic Development Department at 4430 South Adams County Parkway, Suite W2000A Brighton, CO 80601-8216 or call (720) 523-6800 by 10/16/2020 in order that your comments may be taken into consideration in the review of this case. If you would like your comments included verbatim please send your response by way of e-mail to [GJBarnes@adcogov.org](mailto:GJBarnes@adcogov.org).

Once comments have been received and the staff report written, the staff report and notice of public hearing dates may be forwarded to you upon request. The full text of the proposed request and additional colored maps can be obtained by contacting this office or by accessing the Adams County web site at [www.adcogov.org/planning/currentcases](http://www.adcogov.org/planning/currentcases). It may take up to two business days for this information to be posted to the website.

Thank you for your review of this case.

## Greg Barnes

---

**From:** Loeffler - CDOT, Steven <steven.loeffler@state.co.us>  
**Sent:** Thursday, October 8, 2020 8:28 AM  
**To:** Greg Barnes  
**Subject:** Re: For Review: Burke Rezoning (RCU2020-00026)

Please be cautious: This email was sent from outside Adams County

Greg,

I have reviewed the referral for the proposed Burke Rezoning from R-2 to R-3 on property located at 2525 W. 65th Place and have no objections. This property is off the State Highway system.

Thank you for the opportunity to review this referral.

**Steve Loeffler**  
Permits Unit- Region 1



P 303.757.9891 | F 303.757.9886  
2829 W. Howard Pl. 2nd Floor, Denver, CO 80204  
[steven.loeffler@state.co.us](mailto:steven.loeffler@state.co.us) | [www.codot.gov](http://www.codot.gov) | [www.cotrip.org](http://www.cotrip.org)

On Thu, Sep 24, 2020 at 2:51 PM Greg Barnes <[GJBarnes@adcogov.org](mailto:GJBarnes@adcogov.org)> wrote:

The Adams County Planning Commission is requesting comments on the following application: **Zoning map amendment (re-zoning) to change the zoning designation from Residential-2 (R-2) to Residential-3 (R-3)**. This request is located at 2525 W 65th Place. The Assessor's Parcel Number is 0182505404027.

Applicant Information:

JIEJUN BURKE

2525 W. 65TH PL

DENVER, CO 80221

Please forward any written comments on this application to the Community and Economic Development Department at 4430 South Adams County Parkway, Suite W2000A Brighton, CO 80601-8216 or call (720) 523-6800 by 10/16/2020 in order that your comments may be taken into consideration in the review of this



## Greg Barnes

---

**From:** Naso, Kela A. <Kela.Naso@denverwater.org>  
**Sent:** Tuesday, October 20, 2020 1:45 PM  
**To:** Greg Barnes  
**Subject:** RE: For Review: Burke Rezoning (RCU2020-00026)

Please be cautious: This email was sent from outside Adams County

Hi Greg,

Denver Water does not have any comment on the rezoning of this site. The owner should work with Denver Water's Sales Administration group as well as Crestview Water & Sanitation to service the new residential lot. Please let me know if you have any other questions or concerns.

Thank you,

---

**From:** Greg Barnes <GJBarnes@adcogov.org>  
**Sent:** Thursday, September 24, 2020 2:52 PM  
**To:** Greg Barnes <GJBarnes@adcogov.org>  
**Subject:** For Review: Burke Rezoning (RCU2020-00026)

The Adams County Planning Commission is requesting comments on the following application: **Zoning map amendment (re-zoning) to change the zoning designation from Residential-2 (R-2) to Residential-3 (R-3)**. This request is located at 2525 W 65th Place. The Assessor's Parcel Number is 0182505404027.

Applicant Information:  
JIEJUN BURKE  
2525 W. 65TH PL  
DENVER, CO 80221

Please forward any written comments on this application to the Community and Economic Development Department at 4430 South Adams County Parkway, Suite W2000A Brighton, CO 80601-8216 or call (720) 523-6800 by 10/16/2020 in order that your comments may be taken into consideration in the review of this case. If you would like your comments included verbatim please send your response by way of e-mail to [GJBarnes@adcogov.org](mailto:GJBarnes@adcogov.org).

Once comments have been received and the staff report written, the staff report and notice of public hearing dates may be forwarded to you upon request. The full text of the proposed request and additional colored maps can be obtained by contacting this office or by accessing the Adams County web site at [www.adcogov.org/planning/currentcases](http://www.adcogov.org/planning/currentcases). It may take up to two business days for this information to be posted to the website.

Thank you for your review of this case.



### Greg Barnes

Planner III, *Community and Economic Development Dept.*  
ADAMS COUNTY, COLORADO  
4430 S. Adams County Parkway, 1st Floor, Suite W2000A  
Brighton, CO 80601-8216  
720.523.6853 [gjbarnes@adcogov.org](mailto:gjbarnes@adcogov.org)

## Greg Barnes

---

**From:** Courtney Salazar <ar@northpecoswater.org>  
**Sent:** Monday, November 2, 2020 3:00 PM  
**To:** Greg Barnes  
**Subject:** RE: For Review: Burke Variance (VSP2020-00027)

Please be cautious: This email was sent from outside Adams County

Hi Greg,

North Pecos does not have any input as the property is not within our District.

*Courtney Salazar*

Accounts Receivable & Project Coordinator  
North Pecos Water & Sanitation District  
6900 Pecos Street  
Denver, CO 80221

Phone: (303) 429-5770 Fax: (303) 650-8863

[ar@northpecoswater.org](mailto:ar@northpecoswater.org)

---

**From:** Greg Barnes [mailto:[GJBarnes@adcogov.org](mailto:GJBarnes@adcogov.org)]  
**Sent:** Friday, October 30, 2020 1:28 PM  
**To:** Greg Barnes  
**Subject:** For Review: Burke Variance (VSP2020-00027)

The Adams County Board of Adjustment is requesting comments on the following application:

**Variance to allow a property with 76 feet of lot width to be zoned Residential-3 where a minimum of 150 feet of lot width is required. The case is associated with a rezoning application to change the zone designation on the property from Residential-2 to Residential-3 (RCU2020-00026).**

This request is located at 2525 W 65th Place. The Assessor's Parcel Number is 0182505404027

Owner Information: JIEJUN BURKE, 2525 W 65TH PL, DENVER, CO 80221

Please forward any written comments on this application to the Community and Economic Development Department at 4430 South Adams County Parkway, Suite W2000A Brighton, CO 80601-8216 or call (720) 523-6800 by November 19, 2020 in order that your comments may be taken into consideration in the review of this case. If you would like your comments included verbatim please send your response by way of e-mail to [GJBarnes@adcogov.org](mailto:GJBarnes@adcogov.org).

Once comments have been received and the staff report written, the staff report will be forwarded to you. The full text of the proposed request and additional colored maps can be obtained by contacting this office or by accessing the Adams County web site at [www.adcogov.org/planning/currentcases](http://www.adcogov.org/planning/currentcases). It may take a few business days for the case material to be posted to our website. Thank you for your review of this case.

## Greg Barnes

---

**From:** Clayton Woodruff <Clayton.Woodruff@RTD-Denver.com>  
**Sent:** Thursday, October 1, 2020 8:12 AM  
**To:** Greg Barnes  
**Subject:** RE Case Number RCU2020-00026

Please be cautious: This email was sent from outside Adams County

Greg,

The RTD has no comments on this project

Thanks,



**C. Scott Woodruff**

**Engineer III**

Regional Transportation District

1560 Broadway, Suite 700, FAS-73 | Denver, CO 80202

o 303.299.2943 | m 303-720-2025

[clayton.woodruff@rtd-denver.com](mailto:clayton.woodruff@rtd-denver.com)



September 29, 2020

Greg Barnes  
Adams County Community and Economic Development  
4430 South Adams County Parkway, Suite W2000A  
Brighton, CO 80601

RE: Burke Rezoning, RCU2020-00026  
TCHD Case No. 6515

Dear Mr. Barnes,

Thank you for the opportunity to review and comment on the Zoning Map Amendment to change the zoning designation from Residential-2 (R-2) to Residential-3 (R-3) to allow for a triplex on the property located at 2525 W 65<sup>th</sup> Place Tri-County Health Department (TCHD) staff has reviewed the application for compliance with applicable environmental and public health regulations and principles of healthy community design. After reviewing the application, TCHD has no comments.

Please feel free to contact me at 720-200-1585 or [aheinrich@tchd.org](mailto:aheinrich@tchd.org) if you have any questions.

Sincerely,

A handwritten signature in black ink that reads "AHF".

Annemarie Heinrich Fortune, MPH/MURP  
Land Use and Built Environment Specialist

cc: Sheila Lynch, Monte Deatrich, TCHD



**Right of Way & Permits**

1123 West 3<sup>rd</sup> Avenue  
Denver, Colorado 80223  
Telephone: **303.571.3306**  
Facsimile: 303. 571.3284  
donna.l.george@xcelenergy.com

October 16, 2020

Adams County Community and Economic Development Department  
4430 South Adams County Parkway, 3<sup>rd</sup> Floor, Suite W3000  
Brighton, CO 80601

Attn: Greg Barnes

**Re: Burke Rezone, Case # RCU2020-00026**

Public Service Company of Colorado's (PSCo) Right of Way & Permits Referral Desk has reviewed the request for the **Burke Rezone**. Please be advised that Public Service Company has existing natural gas and electric facilities within the areas indicated in this proposed rezone. Public Service Company has no objection to this proposed rezone, contingent upon PSCo's ability to maintain all existing rights and this amendment should not hinder our ability for future expansion, including all present and any future accommodations for natural gas transmission and electric transmission related facilities.

The property owner/developer/contractor must complete the application process for any new natural gas or electric service, or modification to existing facilities via [xcelenergy.com/InstallAndConnect](http://xcelenergy.com/InstallAndConnect). It is then the responsibility of the developer to contact the Designer assigned to the project for approval of design details. Additional easements may need to be acquired by separate document for new facilities.

As a safety precaution, PSCo would like to remind the developer to call the Utility Notification Center by dialing 811 for utility locates prior to construction.

Donna George  
Right of Way and Permits  
Public Service Company of Colorado dba Xcel Energy  
Office: 303-571-3306 – Email: [donna.l.george@xcelenergy.com](mailto:donna.l.george@xcelenergy.com)

## Greg Barnes

---

**From:** Ryan Denison <ryan.denison@gmail.com>  
**Sent:** Wednesday, September 30, 2020 1:50 PM  
**To:** Greg Barnes  
**Subject:** RCU2020-00026

Please be cautious: This email was sent from outside Adams County

Hi,

I am sending over my comments regarding the rezoning of 2525 W. 65th Pl. I am in favor of this. I work as a property manager with Atlas Real Estate in Denver, and it is very apparent to me how lacking the middle size housing availability is currently. There are massive amounts of MFH being built, but the 2-4 unit range of availability is not keeping up with demand. With the planned Federal Blvd Framework, I believe it is necessary to look at the lot size and density requirements in this area and make adjustments to help address the lack of available housing.

A quick question. Does the R3 zoning support up to 4 units?

Thanks,  
Ryan Denison

## Greg Barnes

---

**From:** Greg Barnes  
**Sent:** Friday, October 23, 2020 7:25 AM  
**To:** Greg Barnes  
**Subject:** Opposition

Benjamin Martinez at 2510 W 65<sup>th</sup> Place is opposed to the rezoning  
Benjiem67@yahoo.com



### Greg Barnes

Planner III, *Community and Economic Development Dept.*

ADAMS COUNTY, COLORADO

4430 S. Adams County Parkway, 1st Floor, Suite W2000A

Brighton, CO 80601-8216

720.523.6853 [gjbarnes@adcogov.org](mailto:gjbarnes@adcogov.org)

[adcogov.org](http://adcogov.org)

**Beginning July 27, 2020, my work schedule is:**

Monday – Alternating weeks of 7 am – 3:30 pm and off

Tuesday – Friday – 7 am – 4:30 pm

## Greg Barnes

---

**From:** Greg Barnes  
**Sent:** Tuesday, October 6, 2020 2:58 PM  
**To:** Greg Barnes  
**Subject:** Public Comment: Burke (RCU2020-00026)

Ruben Trujillo is opposed to the rezoning. Mr. Trujillo prefers lower density in the area.



### Greg Barnes

Planner III, *Community and Economic Development Dept.*

ADAMS COUNTY, COLORADO

4430 S. Adams County Parkway, 1st Floor, Suite W2000A

Brighton, CO 80601-8216

720.523.6853 [gjbarnes@adcogov.org](mailto:gjbarnes@adcogov.org)

[adcogov.org](http://adcogov.org)

### Beginning July 27, 2020, my work schedule is:

Monday – Alternating weeks of 7 am – 3:30 pm and off

Tuesday – Friday – 7 am – 4:30 pm





## Request for Comments

Case Name: Burke Lot Width Variance  
Case Number: VSP2020-00027

October 30, 2020

The Adams County Board of Adjustment is requesting comments on the following application: **Variance to allow a property with 76 feet of lot width to be zoned Residential-3 where a minimum of 150 feet of lot width is required. The case is associated with a rezoning application to change the zone designation on the property from Residential-2 to Residential-3 (RCU2020-00026).** This request is located at 2525 W 65th Place. The Assessor's Parcel Number is 0182505404027

Owner Information: JIEJUN BURKE  
2525 W 65TH PL  
DENVER, CO 80221

Please forward any written comments on this application to the Community and Economic Development Department at 4430 South Adams County Parkway, Suite W2000A Brighton, CO 80601-8216 or call (720) 523-6800 by November 19, 2020 in order that your comments may be taken into consideration in the review of this case. If you would like your comments included verbatim please send your response by way of e-mail to [GJBarnes@adcogov.org](mailto:GJBarnes@adcogov.org).

Once comments have been received and the staff report written, the staff report will be forwarded to you. The full text of the proposed request and additional colored maps can be obtained by contacting this office or by accessing the Adams County web site at [www.adcogov.org/planning/currentcases](http://www.adcogov.org/planning/currentcases).

Thank you for your review of this case.

Greg Barnes  
Planner III

BOARD OF COUNTY COMMISSIONERS

Eva J. Henry  
DISTRICT 1

Charles "Chaz" Tedesco  
DISTRICT 2

Emma Pinter  
DISTRICT 3

Steve O'Dorisio  
DISTRICT 4

Mary Hodge  
DISTRICT 5



## Public Hearing Notification

Case Name:	Burke Lot Width Variance
Case Number:	VSP2020-00027
Board of Adjustment Hearing Date:	December 17, 2020 at 6:00 p.m.

November 20, 2020

A public hearing has been set by the Adams County Board of Adjustment to consider the following request: **Variance to allow a property with 76 feet of lot width to be zoned Residential-3 where a minimum of 150 feet of lot width is required.** The Assessor's Parcel Number is 0182505404027 and the address of the request is 2525 West 65<sup>th</sup> Place.

Applicant Information:  
JIEJUN BURKE  
2525 W. 65TH PL  
DENVER, CO 80221

The Board of Adjustment meeting will be held virtually using the Zoom video conferencing software and members of the public will be able to submit comments prior to the start of the public hearing that will then be entered into the record. For instructions on how to access the public hearing via telephone or internet, or to submit comment, please visit <http://www.adcogov.org/board-adjustment> for up to date information.

This will be a public hearing and any interested parties may attend and be heard. The Applicant and Representative's presence at these hearings is requested. The full text of the proposed request and additional colored maps can be obtained by accessing the Adams County Community and Economic Development Department website at [www.adcogov.org/planning/currentcases](http://www.adcogov.org/planning/currentcases). Thank you for your review of this case.

Greg Barnes  
Planner III  
gjbarnes@adcogov.org

## **PUBLICATION REQUEST**

**Case Name:** Burke Rezoning at West 65<sup>th</sup> Place

**Case Number:** RCU2020-00026

**Planning Commission Hearing Date:** January 28, 2021 at 6:00 p.m.

**Board of County Commissioners Hearing Date:** February 23, 2021 at 9:30 a.m.

**Case Manager:** Greg Barnes, [gibarnes@adcogov.org](mailto:gibarnes@adcogov.org), 720-523-6853

**Request:** Zoning map amendment (re-zoning) to change the zoning designation from Residential-2 (R-2) to Residential-3 (R-3).

**Parcel Number:** 0182505404027

**Address of the Request:** 2525 W. 65<sup>th</sup> Place

**Applicant:** Jiejun Burke, 2525 West 65<sup>th</sup> Place, Denver, CO 80221

**Legal Description:** NORTH LAWN GARDENS DESC: LOT 23 EXC N 20 FT FOR RD BLK 1

### **Virtual Meeting and Public Comment Information:**

These meetings will be held virtually. Please visit <http://www.adcogov.org/planning-commission> and <http://www.adcogov.org/bocc> for up to date information on accessing the public hearings and submitting comment prior to the hearings. The full text of the proposed request and additional colored maps can be obtained by accessing the Adams County Community and Economic Development Department website at [www.adcogov.org/planning/currentcases](http://www.adcogov.org/planning/currentcases).



Referral Listing  
Case Number VSP2020-00027  
Burke Lot Width Variance

Agency

Contact Information

Adams County Attorney's Office

Christine Fitch  
4430 S Adams County Pkwy  
Brighton CO 80601  
720-523-6352  
CFitch@adcogov.org

Adams County CEDD Development Services Engineer

Devt. Services Engineering  
4430 S. Adams County Pkwy.  
Brighton CO 80601  
720-523-6800

Adams County CEDD Environmental Services Division

Katie Keefe  
4430 S. Adams County Pkwy.  
Brighton CO 80601  
720-523-6986  
kkeefe@adcogov.org

Adams County CEDD Right-of-Way

Mark Alessi  
4430 S. Adams County Pkwy.  
Brighton CO 80601  
720-523-6837  
malessi@adcogov.org

Adams County Community Safety & Wellbeing, Neighborhood Services

Gail Moon  
  
4430 S. Adams County Pkwy.  
Brighton CO 80601  
720-523-6856  
gmoon@adcogov.org

Adams County Development Services - Building

Justin Blair  
4430 S Adams County Pkwy  
Brighton CO 80601  
720-523-6825  
JBlair@adcogov.org

Adams County Fire Protection District

Carla Gutierrez  
7980 Elmwood Ln.  
Denver CO 80221  
303-539-6862  
cgutierrez@acfpd.org

Adams County Parks and Open Space Department

Marc Pedrucci  
303-637-8014  
mpedrucci@adcogov.org

Adams County Parks and Open Space Department

Aaron Clark  
(303) 637-8005  
aclark@adcogov.org

Agency

Contact Information

---

Adams County Sheriff's Office

Rick Reigenborn  
(303) 654-1850  
rreigenborn@adcogov.org

Adams County Sheriff's Office

--  
303-655-3283  
CommunityConnections@adcogov.org

Arvada Fire Department

Steven Parker  
7903 Alison Way  
Arvada CO 80005  
303-424-3012  
steven.parker@arvadafire.com

BERKELEY NEIGHBORHOOD ASSOC.

GLORIA RUDDEN  
4420 W 52ND PL.  
DENVER CO 80212  
(303) 433-7653 (303) 477-9669  
seminoegrandma@gmail.com

BERKELEY WATER

Paul Peloquin  
4455 W 58TH AVE UNIT A  
Arvada CO 80002  
(303) 477-1914  
paul.peloquin@denverwater.org

BERKELEY WATER & SAN DISTRICT

SHARON WHITEHAIR  
4455 W 58TH AVE UNIT A  
ARVADA CO 80002  
(303) 477-1914  
berkeleywater@gmail.com

CDPHE

Sean Hackett  
4300 S Cherry Creek Dr  
Denver CO 80246  
303.692.3662 303.691.7702  
cdphe\_localreferral@state.co.us

CDPHE - WATER QUALITY PROTECTION SECT

Patrick Pfaltzgraff  
4300 CHERRY CREEK DRIVE SOUTH  
WQCD-B2  
DENVER CO 80246-1530  
303-692-3509  
cdphe\_localreferral@state.co.us

CDPHE SOLID WASTE UNIT

Andy Todd  
4300 CHERRY CREEK DR SOUTH  
HMWMD-CP-B2  
DENVER CO 80246-1530  
303.691.4049  
cdphe\_localreferral@state.co.us

Century Link, Inc

Brandyn Wiedreich  
5325 Zuni St, Rm 728  
Denver CO 80221  
720-578-3724 720-245-0029

Agency

Contact Information

---

City of Arvada

Rob Smetana  
8101 Ralston Rd.  
Arvada CO 80002  
(720)898-7444  
rsmetana@arvada.org

City of Arvada Utilities

Sharon Israel  
8101 Ralston Rd.  
Arvada CO 80002  
720-898-7760  
sisrael@arvada.org

CITY OF WESTMINSTER

Rita McConnell  
4800 W 92ND AVE.  
WESTMINSTER CO 80031  
303-658-2093  
planning@cityofwestminster.us

CITY OF WESTMINSTER

Andy Walsh  
4800 W 92nd Avenue  
WESTMINSTER CO 80031  
303-658-2563  
awalsh@cityofwestminster.us

COLORADO DEPT OF TRANSPORTATION

Steve Loeffler  
2000 S. Holly St.  
Region 1  
Denver CO 80222  
303-757-9891  
steven.loeffler@state.co.us

COLORADO DIVISION OF WILDLIFE

Matt Martinez  
6060 BROADWAY  
DENVER CO 80216-1000  
303-291-7526  
matt.martinez@state.co.us

COLORADO DIVISION OF WILDLIFE

Serena Rocksund  
6060 BROADWAY  
DENVER CO 80216  
3039471798  
serena.rocksund@state.co.us

COMCAST

JOE LOWE  
8490 N UMATILLA ST  
FEDERAL HEIGHTS CO 80260  
303-603-5039

Crestview Water & Sanitation

Patrick Stock  
7145 Mariposa St  
PO Box 21299  
Denver CO 80221-0299  
303-430-1660 303-434-0607  
PatrickStock@crestviewwater.net

Agency

Contact Information

---

GOAT HILL

SHARON WHITEHAIR  
2901 W 63RD  
AVE SP:0047  
DENVER CO 80221  
720 480-2831  
sharonwhitehair@gmail.com

MAPLETON SCHOOL DISTRICT #1

CHARLOTTE CIANCIO  
591 E. 80TH AVE  
DENVER CO 80229  
303-853-1015  
charlotte@mapleton.us

METRO WASTEWATER RECLAMATION

CRAIG SIMMONDS  
6450 YORK ST.  
DENVER CO 80229  
303-286-3338  
CSIMMONDS@MWRD.DST.CO.US

MOBILE GARDENS

VERA MARIE JONES  
6250 FEDERAL #29  
DENVER CO 80221  
303-429-5856

North Lincoln Water and Sanitation District

JORGE HINOJOS  
1560 Broadway  
Suite 1400  
Denver CO 80202  
303-861-0061  
jorge.hinojos@tetrattech.com

North Lincoln Water and Sanitation District

- -  
-  
nlwsdistrict1@gmail.com

North Pecos Water & Sanitation District

Russell Traska  
6900 Pecos St  
Denver CO 80221  
303-429-5770  
manager@northpecoswater.org

North Washington Street Water & San Dist

Mike DeMattee  
3172 E 78th Ave  
Denver CO 80229  
303-288-6664  
mdemattee@nwsbsd.com

NORTHRIDGE ESTATES AT GOLD RUN HOA

SHANE LUSSIER  
14901 E Hampden Ave  
Suite 320  
AURORA CO 80014  
303-693-2118  
shane@cchoapros.com

NS - Code Compliance

Kerry Gress  
kgress@adcogovorg  
720.523.6832  
kgress@adcogov.org

Agency

Contact Information

---

NS - Code Compliance

Brooke Pettry  
4430 S. Adams County Pkwy  
Brighton CO 80601  
720.523.6206  
bpettry@adcogov.org

NS - Code Compliance

Joaquin Flores  
720.523.6207  
jflores@adcogov.org

Pecos Park Logistics Park Metro District

M Mitchell  
4221 Brighton Blvd  
Denver CO 802163719  
303-298-1111  
mmitchell@westfield-co.com

PERL MACK NEIGHBORHOOD GROUP

DAN MICEK - PRESIDENT  
7294 NAVAJO ST.  
DENVER CO 80221  
303-428-8557  
DANMICEK54@COMCAST.NET

Pomponio Terrace Metropolitan District

Zachary White  
2154 E. Commons Avenue, #2000  
Centennial CO 80122  
0  
zwhite@wbapc.com

REGIONAL TRANSPORTATION DIST.

Engineering RTD  
1560 BROADWAY SUITE 700  
DENVER CO 80202  
303-299-2439  
engineering@rtd-denver.com

The TOD Group

THE TOD GROUP  
1431 Euterpe Street  
New Orleans LA 70130  
5047174718

TRI-COUNTY HEALTH DEPARTMENT

Sheila Lynch  
6162 S WILLOW DR, SUITE 100  
GREENWOOD VILLAGE CO 80111  
720-200-1571  
landuse@tchd.org

TRI-COUNTY HEALTH DEPARTMENT

MONTE DEATRICH  
4201 E. 72ND AVENUE SUITE D  
COMMERCE CITY CO 80022  
(303) 288-6816  
mdeatrich@tchd.org

Tri-County Health: Mail CHECK to Sheila Lynch

Tri-County Health  
landuse@tchd.org  
.

UNION PACIFIC RAILROAD

Anna Dancer  
1400 DOUGLAS ST STOP 1690  
OMAHA NE 68179  
402-544-2255  
aldancer@up.com



Agency

Contact Information

---

WELBY CITIZEN GROUP

NORMA FRANK  
7401 RACE STREET  
DENVER CO 80229  
(303) 288-3152

WESTMINSTER FIRE DEPT.

CAPTAIN DOUG HALL  
9110 YATES ST.  
WESTMINSTER CO 80031  
303-430-2400 x4542  
dhall@ci.westminster.co.us

WESTMINSTER SCHOOL DISTRICT #50

Jackie Peterson  
7002 Raleigh Street  
WESTMINSTER CO 80030  
720-542-5100  
jpeterson@adams50.org

Xcel Energy

Donna George  
1123 W 3rd Ave  
DENVER CO 80223  
303-571-3306  
Donna.L.George@xcelenergy.com

Xcel Energy

Donna George  
1123 W 3rd Ave  
DENVER CO 80223  
303-571-3306  
Donna.L.George@xcelenergy.com

2597 W 64TH AVENUE LLC  
6167 INDEPENDENCE ST  
ARVADA CO 80004-5375

CRESTVIEW WATER AND SANITATION DISTRICT  
PO BOX 21299  
DENVER CO 80221-0299

2661 W 65TH PLACE LLC  
PO BOX 1500  
ARVADA CO 80001-1500

DALLAS ROBERT  
7798 QUIVAS ST  
DENVER CO 80221-4228

ADAMS COUNTY  
4430 SOUTH ADAMS COUNTY PKWY  
BRIGHTON CO 80601-8204

DENISON REAL ESTATE & INVESTMENT LLC  
25193 N TURKEY CREEK RD  
EVERGREEN CO 80439-5243

ARCHDIOCESE OF DENVER THE  
OUR LADY OF VISITATION  
1300 SOUTH STEELE STREET  
DENVER CO 80210

ESPERANZA HOLDING COMPANY LLC  
1123 SANTA FE DR  
DENVER CO 80204-3543

ARCHULETA JOSEPH AND  
ARCHULETA KATY E  
2621 W 65TH PLACE  
DENVER CO 80221

FEDERAL CREDIT LLC  
2655 W 39TH AVE  
DENVER CO 80211-2107

BPI WESTMINSTER LLC  
2880 BRYANT ST  
DENVER CO 80211-4223

FOUR H PROPERTIES  
114 RIDGE RD  
EVERGREEN CO 80439

BURKE JIEJUN  
14634 W 62ND PL  
ARVADA CO 80004-3621

GATEWAY CENTRAL 64 LLC  
600 S CHERRY ST STE 625  
GLENDALE CO 80246-1710

CHAVEZ ROSE ANN MARIE AND  
HAUGEN JAMES B  
4122 KING ST  
DENVER CO 80211-1612

GREVIOUS GERALD  
PO BOX 21334  
DENVER CO 80221-0334

CITY OF WESTMINSTER  
4800 W 92ND AVE  
WESTMINSTER CO 80030-6399

HANEY VIRGINIA  
2575 W 65TH AVE  
DENVER CO 80221-2339

CLEAR CREEK STATION METROPOLITAN DISTRICT NO  
1  
C/O MSI LLC  
11002 BENTON ST  
WESTMINSTER CO 80020-3200

INTEROCITOR ASSETS LLC  
2613 W 64TH AVE UNIT B  
DENVER CO 80221-2370

JAIME EDI S AND  
JAIME SANDRA V  
1146 S KENDALL CT  
LAKEWOOD CO 80232-5751

NEW DIRECTION IRA VANNA ROBBINS IRA  
1070 W CENTURY DR APT 101  
LOUISVILLE CO 80027

JORGENSEN COMPANIES LIMITED LLC  
11037 CLAY DR  
WESTMINSTER CO 80234-4695

OROZCO MARIA V AND OROZCO MANUEL  
1799 E 96TH WAY  
DENVER CO 80229-2415

JOWERS RONALD F  
2520 W 65TH PL  
DENVER CO 80221

ORTIZ MARCELLINO J AND ORTIZ LISA M  
2415 W 65TH AVE  
DENVER CO 80221-2310

LARSON STEVEN H AND  
LARSON VICKI J  
15819 LONGVIEW DR  
BROOMFIELD CO 80023-9431

ORTIZ MARCELLINO J AND ORTIZ LISA M  
2435 W 65TH AVE  
DENVER CO 80221-2310

LEGER PROPERTY GROUP LLC  
303 S BROADWAY STE 200-350  
DENVER CO 80209-1558

PAIZ CASIMIRO JR  
11042 ROSALIE DR  
DENVER CO 80233-3558

MARTINEZ DAMARIS  
3613 S FLANDERS ST  
AURORA CO 80013-3949

PAIZ CASIMIRO JR AND  
PAIZ MARY M  
11042 ROSALIE DR  
DENVER CO 80233-3558

MIDTOWN FACILITY LLC  
6465 GREENWOOD PLAZA BLVD STE 700  
CENTENNIAL CO 80111-7103

PEREA MAIRA AND  
RAMIREZ LORETO  
13683 DEXTER ST  
THORNTON CO 80602-6970

MIDTOWN LLC  
6465 GREENWOOD PLAZA BLVD STE 700  
ENGLEWOOD CO 80111-7103

POMPONIO TERRACE HOLDINGS LLC  
ATTN JAMES R MERLINO  
9110 E NICHOLS AVE SUITE 120  
CENTENNIAL CO 80112

MILINAZZO RICHARD  
2434 TYRRHENIAN CIRCLE  
LONGMONT CO 80504-3762

PROLIC JEREMY AND  
PROLIC KRISTEN W  
2376 WEST 67TH DR  
DENVER CO 80221

MOWINSKI DAN AND  
LIKENS KIMBERLY  
2581 W 66TH PL  
DENVER CO 80221-2213

RAB77 LLC  
2611 W 64TH AVE UNIT F  
DENVER CO 80221-2368

REPLOGLE BILLY L AND  
REPLOGLE AYAKO  
PO BOX 21124  
DENVER CO 80221

VAGHER INVESTMENTS LLC  
1935 SNOWY OWL DR  
BROOMFIELD CO 80020-0612

RIVERA LUKE  
9975 WADSWORTH PKWY K-2 264  
WESTMINSTER CO 80021

VASILS TOY BOX LLC  
1001 CRAIG RD STE 115  
SAINT LOUIS MO 63146-5293

RIVERA LUKE W  
9975 WADSWORTH PKWY K-2 264  
WESTMINSTER CO 80021

VERHEY RICHARD J AND  
VERHEY JANETTE M  
116 KRAMERIA ST  
DENVER CO 80220-5929

ROBLES SAMUEL AND  
ACEVEDO MANUEL ROBLES  
6502-04 CLAY STREET  
DENVER CO 80221

VERHEY RICHARD J/JANETTE M/RICHARD J  
VERHEY JANETTE M  
116 KRAMERIA ST  
DENVER CO 80220-5929

RSM INVESTMENT CO LLC  
1770 E 69TH AVE  
DENVER CO 80229

W 65TH PROPERTY MANAGEMENT LLC  
11084 LEROY DR  
NORTHGLENN CO 80233-3617

SALVATION ARMY THE  
PO BOX 2369  
DENVER CO 80201

WANGMO SONAM  
12734 UTICA CIR  
BROOMFIELD CO 80020-5783

SEDBERRY PEARL M  
3247 S STUART ST  
DENVER CO 80236-3718

WELLS CHARLES J AND  
WELLS SHARON L  
2580 W 66TH PL  
DENVER CO 80221-2214

SEEMEN FAMILY LIMITED  
PARTNERSHIP THE  
10337 MEADE LOOP  
WESTMINSTER CO 80031-2446

WELLS CHARLES J AND  
WELLS SHARON  
2580 W 66TH PL  
DENVER CO 80221-2214

TANOUE RALPH K  
6356 W 68TH PLACE  
ARVADA CO 80003

WERSHAW ROBERT L/ ESTHER B 1/3 JT AND  
WERSHAW ROBERT L 2/3 INT  
1566 WINONA CT  
DENVER CO 80204-1143

URBAN DRAINAGE AND  
FLOOD CONTROL DISTRICT  
2480 W 26TH AVE SUITE 156B  
DENVER CO 80211

ARCHULETA JOSEPH AND  
ARCHULETA KATY E  
OR CURRENT RESIDENT  
2621 W 65TH PLACE  
DENVER CO 80221

ARGOV ETHAN AND  
KATZ HANNAH  
OR CURRENT RESIDENT  
6708 ZUNI ST  
DENVER CO 80221-2698

COELHO JAMES R  
OR CURRENT RESIDENT  
2701 W 66TH PL  
DENVER CO 80221-2217

BARRETT GRAHAM J AND  
BARRETT TAYLOR A  
OR CURRENT RESIDENT  
6650 ZUNI ST  
DENVER CO 80221-2697

CONNELLY LUCINDA L  
OR CURRENT RESIDENT  
6604 FERN DR  
DENVER CO 80221-2645

BERNARD KARA AND  
BERNARD RUSSELL JAMES  
OR CURRENT RESIDENT  
6638 ZUNI ST  
DENVER CO 80221-2697

COOPER CHRISTOPHER  
OR CURRENT RESIDENT  
6602 FERN DR  
DENVER CO 80221-2645

BINDBEUTEL DAVID J AND  
BINDBEUTEL MARY ANN  
OR CURRENT RESIDENT  
6724 ZUNI ST  
DENVER CO 80221-2698

CORDOVA CRISTOBAL AND  
CORDOVA MARY LEE  
OR CURRENT RESIDENT  
2490 W 65TH PL  
DENVER CO 80221-2222

BITZKOWSKI LAURIE  
OR CURRENT RESIDENT  
2540 W 65TH AVE  
DENVER CO 80221-2324

DAILEY GREGORY R AND  
DAILEY REBECCA E  
OR CURRENT RESIDENT  
2327 W 66TH AVE  
DENVER CO 80221-2692

BROOME GREGORY ALLEN JR AND  
BROOME EMILY  
OR CURRENT RESIDENT  
2332 W 66TH AVE  
DENVER CO 80221-2692

DAVIS CHRISTOPHER H AND  
STEEDMAN KRISTIN  
OR CURRENT RESIDENT  
6678 ZUNI ST  
DENVER CO 80221-2697

CABRIALES RAUL  
OR CURRENT RESIDENT  
2765 W 65TH AVE  
DENVER CO 80221-2311

DOMINGUEZ RONALD J  
OR CURRENT RESIDENT  
2540 W 65TH PLACE  
DENVER CO 80221

CANGEMI JAIME M AND  
CANGEMI THOMAS  
OR CURRENT RESIDENT  
6600 ZUNI ST  
DENVER CO 80221-2697

EMOND THOMAS J  
OR CURRENT RESIDENT  
2364 W 67TH DR  
DENVER CO 80221-2623

CASIAS ZACHERIAH JOHN AND  
GARCIA ANGEL ANNETTE  
OR CURRENT RESIDENT  
2530 W 65TH AVE  
DENVER CO 80221-2324

ESPINOSA MARK AND  
ESPINOSA SERGIO  
OR CURRENT RESIDENT  
6685 FERN DR  
DENVER CO 80221-2695

CHAVEZ JUAN RICARDO  
OR CURRENT RESIDENT  
2555 W 65TH PL  
DENVER CO 80221-2201

FERGUSON LOIS J  
OR CURRENT RESIDENT  
2461 W 65TH PL  
DENVER CO 80221-2223

FERNANDEZ ANNETTE  
OR CURRENT RESIDENT  
2525 W 65TH AVE  
DENVER CO 80221-2339

HERRERA RICHARD AND  
SANCHEZ LIZZETTE A  
OR CURRENT RESIDENT  
6620 FERN DR  
DENVER CO 80221

FRAZIER GARY W  
OR CURRENT RESIDENT  
2703 W 66TH PL  
DENVER CO 80221-2217

HILL CLARK AND  
HILL WESLEY  
OR CURRENT RESIDENT  
6694 ZUNI ST  
DENVER CO 80221-2697

FRONT RANGE AUTO SALES LLC  
OR CURRENT RESIDENT  
2611 W 64TH AVE UNIT D  
DENVER CO 80221-2368

HUA BRANDON M AND  
HUA JASMINE T  
OR CURRENT RESIDENT  
2282 W 66TH AVE  
DENVER CO 80221-2691

GARCIA PORTIA L AND  
GARCIA DANIEL A  
OR CURRENT RESIDENT  
2480 W 65TH PL  
DENVER CO 80221-2222

INSKEEP CHARLES C AND  
INSKEEP CLAUDETTE M  
OR CURRENT RESIDENT  
2620 W 66TH PL  
DENVER CO 80221-2218

GOMEZ GABINO  
OR CURRENT RESIDENT  
2505 W 65TH AVE  
DENVER CO 80221-2339

INTEROCITOR ASSETS LLC  
OR CURRENT RESIDENT  
2613 W 64TH AVE UNIT A  
DENVER CO 80221-2370

GONZALES ANDRES AND  
GONZALES LEONA C  
OR CURRENT RESIDENT  
2700 W 65TH PLACE  
DENVER CO 80221

JACKSON EMILY E AND  
JACKSON BRIAN G  
OR CURRENT RESIDENT  
6601 FERN DR  
DENVER CO 80221-2695

GONZALES RYAN R AND  
GONZALES ALYSSA L  
OR CURRENT RESIDENT  
6684 ZUNI ST  
DENVER CO 80221-2697

JOHNSON LIN VO AND  
JOHNSON ALEXANDER SCOTT  
OR CURRENT RESIDENT  
2310 W 66TH AVE  
DENVER CO 80221-2692

HANCOCK BRIAN L AND  
HANCOCK MICHELLE E  
OR CURRENT RESIDENT  
2356 W 67TH DR  
DENVER CO 80221-2623

JORGENSEN DUSTIN M  
OR CURRENT RESIDENT  
2520 W 65TH AVE  
DENVER CO 80221-2324

HANEY VIRGINIA  
OR CURRENT RESIDENT  
2575 W 65TH AVE  
DENVER CO 80221-2339

JOWERS RONALD F  
OR CURRENT RESIDENT  
2520 W 65TH PL  
DENVER CO 80221

HARRINGTON MARK  
OR CURRENT RESIDENT  
6713 FERN DR  
DENVER CO 80221-2696

KELLOGG EUGENE D  
OR CURRENT RESIDENT  
2700 W 66TH PLACE  
DENVER CO 80221

KIRCHBERG KEITH J AND  
KIRCHBERG MIRINDA  
OR CURRENT RESIDENT  
6606 FERN DR  
DENVER CO 80221-2645

MANES MARK AND  
PARKER MICHELLE  
OR CURRENT RESIDENT  
6637 FERN DR  
DENVER CO 80221-2695

KURTS JOHN  
OR CURRENT RESIDENT  
2320 W 67TH DR  
DENVER CO 80221-2623

MANN ANTHONY AND  
MANN JESSICA  
OR CURRENT RESIDENT  
6658 ZUNI ST  
DENVER CO 80221-2697

LAM THI AND  
LAM EMMA  
OR CURRENT RESIDENT  
6719 FERN DR  
DENVER CO 80221-2696

MARKWELL MEGGI S  
OR CURRENT RESIDENT  
2388 W 67TH DR  
DENVER CO 80221

LIPPINCOTT TROY AND  
LIPPINCOTT ELENA  
OR CURRENT RESIDENT  
6702 ZUNI ST  
DENVER CO 80221-2698

MARQUEZ DANIEL L AND  
MARQUEZ SUZANNA M  
OR CURRENT RESIDENT  
2641 W 65TH PL  
DENVER CO 80221-2201

LOPEZ GABRIEL  
OR CURRENT RESIDENT  
2570 W 65TH PL  
DENVER CO 80221-2205

MARQUEZ JAMES VICTOR AND  
MARQUEZ LISA K  
OR CURRENT RESIDENT  
2661 W 66TH PL  
DENVER CO 80221

LORENZEN CASEY AND  
LORENZEN KELLY  
OR CURRENT RESIDENT  
2339 W 66TH AVE  
DENVER CO 80221-2692

MARTINEZ ANTONIO SOLIS AND  
GARCIA GRISELDA SANTILLANO  
OR CURRENT RESIDENT  
2555 W 65TH AVE  
DENVER CO 80221-2339

LOVI Z LLC  
OR CURRENT RESIDENT  
2611 W 64TH AVE UNIT A  
DENVER CO 80221-2368

MARTINEZ BENJAMIN  
OR CURRENT RESIDENT  
2510 W 65TH PL  
DENVER CO 80221-2205

LUTZ JAMES CHRISTOPHER AND  
MICHALOWSKI SARAH  
OR CURRENT RESIDENT  
6612 ZUNI ST  
DENVER CO 80221-2697

MARTINEZ UNA AND  
MARTINEZ LOUIE E  
OR CURRENT RESIDENT  
2621 W 64TH AVE  
DENVER CO 80221

MADERA JUAN JOSE  
OR CURRENT RESIDENT  
2515 W 65TH AVE  
DENVER CO 80221

MATLACK CODY C AND  
MATLACK NICHOLE  
OR CURRENT RESIDENT  
2680 W 66TH PL  
DENVER CO 80221-2218

MALDONADO DALIA  
OR CURRENT RESIDENT  
2620 W 65TH PL  
DENVER CO 80221-2235

MINO DAVID C AND  
BURCHETT BRITTNEY  
OR CURRENT RESIDENT  
6625 FERN DR  
DENVER CO 80221-2695

MOBLEY AARON KYLE AND  
MOBLEY JULIE DIANNE  
OR CURRENT RESIDENT  
2270 W 66TH AVE  
DENVER CO 80221-2691

OLIVAS KATHLEEN A AND  
OLIVAS ANTHONY H J  
OR CURRENT RESIDENT  
2585 W 65TH AVE  
DENVER CO 80221-2339

MONTOYA CARMELITA P AND  
MASIAS ERNESTINA  
OR CURRENT RESIDENT  
2557 W 65TH AVE  
DENVER CO 80221-2339

ORTIZ-URRUTIA RICARDO A  
OR CURRENT RESIDENT  
6519 CLAY ST  
DENVER CO 80221-2315

MORA JUAN  
OR CURRENT RESIDENT  
2701 W 65TH AVE  
DENVER CO 80221-2311

PAIZ CASIMIRO  
PAIZ MARY MARTHA  
OR CURRENT RESIDENT  
2460 W 65TH PL  
DENVER CO 80221-2222

MORUA CHRISTIAN MICHEL MORALES  
OR CURRENT RESIDENT  
2520 W 66TH PL  
DENVER CO 80221-2214

PATEL HEMALINEEBEN  
OR CURRENT RESIDENT  
6673 FERN DR  
DENVER CO 80221-2695

MOWINSKI DAN AND  
LIKENS KIMBERLY  
OR CURRENT RESIDENT  
2581 W 66TH PL  
DENVER CO 80221-2213

PHILBROOK DAVID W TRUST  
OR CURRENT RESIDENT  
2704 W 65TH PL  
DENVER CO 80221-2208

MURADYAN TIGRAN AND  
MURADYAN EMILY  
OR CURRENT RESIDENT  
2343 W 66TH AVE  
DENVER CO 80221-2692

PHILLIPS KELLAN AND  
PHILLIPS KATHERINE  
OR CURRENT RESIDENT  
2342 W 67TH DR  
DENVER CO 80221-2623

NEYENS EUGENE M  
OR CURRENT RESIDENT  
2570 W 66TH PL  
DENVER CO 80221-2214

PIPER DANIELA MOLINA AND  
ADAMI KALEEN  
OR CURRENT RESIDENT  
2354 W 66TH AVE  
DENVER CO 80221-2692

NGUYEN JESSE AND  
NGUYEN NGA  
OR CURRENT RESIDENT  
2294 W 66TH AVE  
DENVER CO 80221-2691

PLEBAN CHRISTINE A UND 76% INT AND  
NEWMAN MATT UND 24% INT  
OR CURRENT RESIDENT  
6716 ZUNI ST  
DENVER CO 80221-2698

NIEWNOW ZACHERY AND  
CAMPBELL CHRISTOPHER  
OR CURRENT RESIDENT  
2315 W 66TH AVE  
DENVER CO 80221-2692

RAB77 LLC  
OR CURRENT RESIDENT  
2611 W 64TH AVE UNIT F  
DENVER CO 80221-2368

NORTH DENVER APOSTOLIC CHURCH  
OF JESUS INC  
OR CURRENT RESIDENT  
2552 W 65TH PL  
DENVER CO 80221

RAIGOSA DANIEL SR AND  
RAIGOSA OLIVIA  
OR CURRENT RESIDENT  
2705 W 65TH PLACE  
DENVER CO 80221



RANGEL KEVIN B AND  
RANGEL ADRIANNE  
OR CURRENT RESIDENT  
6613 FERN DR  
DENVER CO 80221-2695

TARAVELLA ERIC J  
OR CURRENT RESIDENT  
6624 ZUNI ST  
DENVER CO 80221-2697

RICE PETER AND  
BARRON ALISHA  
OR CURRENT RESIDENT  
6707 FERN DR  
DENVER CO 80221-2696

TEORE LISA C  
OR CURRENT RESIDENT  
6651 FERN DR  
DENVER CO 80221-2695

RIMBERT GARY A AND  
RIMBERT JARID  
OR CURRENT RESIDENT  
2535 W 65TH AVE  
DENVER CO 80221-2339

TOPOLKO MARIO AND  
TOPOLKO ALEXANDRIA S  
OR CURRENT RESIDENT  
6649 FERN DR  
DENVER CO 80221-2695

ROJO LINDA LOU  
OR CURRENT RESIDENT  
2550 W 66TH PL  
DENVER CO 80221-2214

TRUJILLO RUBEN MANUEL  
OR CURRENT RESIDENT  
2530 W 65TH PL  
DENVER CO 80221-2205

RUSSELL JENNIFER  
OR CURRENT RESIDENT  
2376 W 66TH AVE  
DENVER CO 80221-2692

UDVARI DANIEL AND  
GUAZZI GAIA  
OR CURRENT RESIDENT  
6608 FERN DR  
DENVER CO 80221-2645

SANCHEZ AURELIO TORRES AND  
TORRES CHRISTINA V  
OR CURRENT RESIDENT  
2693 W 65TH PL  
DENVER CO 80221-2201

VIGIL ANTONIO F AND  
VIGIL IRENE M  
OR CURRENT RESIDENT  
6500 CLAY ST  
DENVER CO 80221-2316

SANCHEZ EDUARDO  
OR CURRENT RESIDENT  
2745 W 65TH AVENUE  
DENVER CO 80221

VIGIL ODELIA  
OR CURRENT RESIDENT  
2650 W 66TH PL  
DENVER CO 80221-2218

SANTELLA DONNA LYNN  
OR CURRENT RESIDENT  
2681 W 66TH PL  
DENVER CO 80221-2217

WEAVER DEBORAH K  
OR CURRENT RESIDENT  
2475 W 65TH AVE  
DENVER CO 80221

SCHMIDT MARK  
OR CURRENT RESIDENT  
6640 FERN DR  
DENVER CO 80221

WEBSTER STEVEN THOMAS  
OR CURRENT RESIDENT  
6531 CLAY ST  
DENVER CO 80221-2315

SMITH PAMELA K AND  
SMITH DAVID A  
OR CURRENT RESIDENT  
6630 FERN DR  
DENVER CO 80221

WELLS CHARLES J JR AND  
WELLS SHARON  
OR CURRENT RESIDENT  
2580 W 66TH PLACE  
DENVER CO 80221

WILLIAMS KEN C AND  
MULLIN MARY KATHERINE  
OR CURRENT RESIDENT  
6610 FERN DR  
DENVER CO 80221

CURRENT RESIDENT  
2821 W 65TH PL  
DENVER CO 80221-2209

WOODS ALISHA A  
OR CURRENT RESIDENT  
6720 ZUNI ST  
DENVER CO 80221-2698

CURRENT RESIDENT  
2561 W 66TH PL  
DENVER CO 80221-2213

WOOTEN CHRISTOPHER M AND  
WOOTEN JENNIFER L  
OR CURRENT RESIDENT  
6712 ZUNI ST  
DENVER CO 80221-2698

CURRENT RESIDENT  
2560 W 66TH PL  
DENVER CO 80221-2214

WRIGHT JOHN A AND  
CONOVER JACOB N  
OR CURRENT RESIDENT  
6670 ZUNI ST  
DENVER CO 80221-2697

CURRENT RESIDENT  
2590 W 66TH PL  
DENVER CO 80221-2214

CURRENT RESIDENT  
2525 W 65TH PL  
DENVER CO 80221-2201

CURRENT RESIDENT  
2621 W 66TH PL  
DENVER CO 80221-2217

CURRENT RESIDENT  
2531 W 65TH PL  
DENVER CO 80221-2201

CURRENT RESIDENT  
2702 W 66TH PL  
DENVER CO 80221-2218

CURRENT RESIDENT  
2595 W 65TH PL  
DENVER CO 80221-2201

CURRENT RESIDENT  
2704 W 66TH PL  
DENVER CO 80221-2218

CURRENT RESIDENT  
2661 W 65TH PL  
DENVER CO 80221-2201

CURRENT RESIDENT  
2441 W 65TH PL  
DENVER CO 80221-2223

CURRENT RESIDENT  
2681 W 65TH PL  
DENVER CO 80221-2201

CURRENT RESIDENT  
2650 W 65TH PL  
DENVER CO 80221-2235

CURRENT RESIDENT  
2740 W 65TH PL  
DENVER CO 80221-2208

CURRENT RESIDENT  
2652 W 65TH PL  
DENVER CO 80221-2235

CURRENT RESIDENT  
2654 W 65TH PL  
DENVER CO 80221-2235

CURRENT RESIDENT  
2520 W 65TH PL APT 3  
DENVER CO 80221-2240

CURRENT RESIDENT  
2656 W 65TH PL  
DENVER CO 80221-2235

CURRENT RESIDENT  
2621 W 65TH PL APT A  
DENVER CO 80221-2242

CURRENT RESIDENT  
2658 W 65TH PL  
DENVER CO 80221-2235

CURRENT RESIDENT  
2621 W 65TH PL APT B  
DENVER CO 80221-2242

CURRENT RESIDENT  
2660 W 65TH PL  
DENVER CO 80221-2235

CURRENT RESIDENT  
2481 W 65TH PL UNIT A  
DENVER CO 80221-2254

CURRENT RESIDENT  
2662 W 65TH PL  
DENVER CO 80221-2235

CURRENT RESIDENT  
2481 W 65TH PL UNIT B  
DENVER CO 80221-2254

CURRENT RESIDENT  
2664 W 65TH PL  
DENVER CO 80221-2235

CURRENT RESIDENT  
2511 W 65TH PL UNIT A  
DENVER CO 80221-2255

CURRENT RESIDENT  
2666 W 65TH PL  
DENVER CO 80221-2235

CURRENT RESIDENT  
2511 W 65TH PL UNIT B  
DENVER CO 80221-2255

CURRENT RESIDENT  
2668 W 65TH PL  
DENVER CO 80221-2235

CURRENT RESIDENT  
2681 W 64TH AVE  
DENVER CO 80221-2302

CURRENT RESIDENT  
2520 W 65TH PL APT 1  
DENVER CO 80221-2240

CURRENT RESIDENT  
2415 W 65TH AVE  
DENVER CO 80221-2310

CURRENT RESIDENT  
2520 W 65TH PL APT 2  
DENVER CO 80221-2240

CURRENT RESIDENT  
2435 W 65TH AVE  
DENVER CO 80221-2310

CURRENT RESIDENT  
2465 W 65TH AVE  
DENVER CO 80221-2310

CURRENT RESIDENT  
2597 W 64TH AVE UNIT 10  
DENVER CO 80221-2321

CURRENT RESIDENT  
6502 CLAY ST  
WESTMINSTER CO 80221-2316

CURRENT RESIDENT  
2597 W 64TH AVE UNIT 11  
DENVER CO 80221-2321

CURRENT RESIDENT  
6520 CLAY ST  
WESTMINSTER CO 80221-2316

CURRENT RESIDENT  
2597 W 64TH AVE UNIT 5  
DENVER CO 80221-2321

CURRENT RESIDENT  
6521 CLAY ST LOT 12  
WESTMINSTER CO 80221-2319

CURRENT RESIDENT  
2597 W 64TH AVE UNIT 7  
DENVER CO 80221-2321

CURRENT RESIDENT  
6521 CLAY ST LOT 36A  
WESTMINSTER CO 80221-2319

CURRENT RESIDENT  
2597 W 64TH AVE UNIT 9  
DENVER CO 80221-2321

CURRENT RESIDENT  
6521 CLAY ST LOT 36B  
WESTMINSTER CO 80221-2319

CURRENT RESIDENT  
2401 W 64TH AVE  
DENVER CO 80221-2323

CURRENT RESIDENT  
6521 CLAY ST LOT 36C  
WESTMINSTER CO 80221-2319

CURRENT RESIDENT  
6521 CLAY ST LOT 10  
WESTMINSTER CO 80221-2333

CURRENT RESIDENT  
6521 CLAY ST LOT 44  
WESTMINSTER CO 80221-2319

CURRENT RESIDENT  
6521 CLAY ST LOT 11  
WESTMINSTER CO 80221-2333

CURRENT RESIDENT  
6521 CLAY ST LOT 45  
WESTMINSTER CO 80221-2319

CURRENT RESIDENT  
6521 CLAY ST LOT 2  
WESTMINSTER CO 80221-2333

CURRENT RESIDENT  
2597 W 64TH AVE UNIT 1  
DENVER CO 80221-2321

CURRENT RESIDENT  
6521 CLAY ST LOT 3  
WESTMINSTER CO 80221-2333

CURRENT RESIDENT  
6521 CLAY ST LOT 4  
WESTMINSTER CO 80221-2333

CURRENT RESIDENT  
6521 CLAY ST LOT 17  
WESTMINSTER CO 80221-2334

CURRENT RESIDENT  
6521 CLAY ST LOT 5  
WESTMINSTER CO 80221-2333

CURRENT RESIDENT  
6521 CLAY ST LOT 18  
WESTMINSTER CO 80221-2334

CURRENT RESIDENT  
6521 CLAY ST LOT 6  
WESTMINSTER CO 80221-2333

CURRENT RESIDENT  
6521 CLAY ST LOT 19  
WESTMINSTER CO 80221-2334

CURRENT RESIDENT  
6521 CLAY ST LOT 7  
WESTMINSTER CO 80221-2333

CURRENT RESIDENT  
6521 CLAY ST LOT 20  
WESTMINSTER CO 80221-2334

CURRENT RESIDENT  
6521 CLAY ST LOT 8  
WESTMINSTER CO 80221-2333

CURRENT RESIDENT  
6521 CLAY ST LOT 21  
WESTMINSTER CO 80221-2334

CURRENT RESIDENT  
6521 CLAY ST LOT 9  
WESTMINSTER CO 80221-2333

CURRENT RESIDENT  
6521 CLAY ST LOT 22  
WESTMINSTER CO 80221-2334

CURRENT RESIDENT  
6521 CLAY ST LOT 13  
WESTMINSTER CO 80221-2334

CURRENT RESIDENT  
6521 CLAY ST LOT 23  
WESTMINSTER CO 80221-2335

CURRENT RESIDENT  
6521 CLAY ST LOT 14  
WESTMINSTER CO 80221-2334

CURRENT RESIDENT  
6521 CLAY ST LOT 24  
WESTMINSTER CO 80221-2335

CURRENT RESIDENT  
6521 CLAY ST LOT 15  
WESTMINSTER CO 80221-2334

CURRENT RESIDENT  
6521 CLAY ST LOT 25  
WESTMINSTER CO 80221-2335

CURRENT RESIDENT  
6521 CLAY ST LOT 16  
WESTMINSTER CO 80221-2334

CURRENT RESIDENT  
6521 CLAY ST LOT 26  
WESTMINSTER CO 80221-2335

CURRENT RESIDENT  
6521 CLAY ST LOT 27  
WESTMINSTER CO 80221-2335

CURRENT RESIDENT  
6521 CLAY ST LOT 38  
WESTMINSTER CO 80221-2336

CURRENT RESIDENT  
6521 CLAY ST LOT 28  
WESTMINSTER CO 80221-2335

CURRENT RESIDENT  
6521 CLAY ST LOT 39  
WESTMINSTER CO 80221-2336

CURRENT RESIDENT  
6521 CLAY ST LOT 29  
WESTMINSTER CO 80221-2335

CURRENT RESIDENT  
6521 CLAY ST LOT 40  
WESTMINSTER CO 80221-2336

CURRENT RESIDENT  
6521 CLAY ST LOT 30  
WESTMINSTER CO 80221-2335

CURRENT RESIDENT  
6521 CLAY ST LOT 41  
WESTMINSTER CO 80221-2336

CURRENT RESIDENT  
6521 CLAY ST LOT 31  
WESTMINSTER CO 80221-2335

CURRENT RESIDENT  
6521 CLAY ST LOT 42  
WESTMINSTER CO 80221-2336

CURRENT RESIDENT  
6521 CLAY ST LOT 32  
WESTMINSTER CO 80221-2335

CURRENT RESIDENT  
6521 CLAY ST LOT 43  
WESTMINSTER CO 80221-2336

CURRENT RESIDENT  
6521 CLAY ST LOT 33  
WESTMINSTER CO 80221-2336

CURRENT RESIDENT  
2545 W 65TH AVE  
DENVER CO 80221-2339

CURRENT RESIDENT  
6521 CLAY ST LOT 34  
WESTMINSTER CO 80221-2336

CURRENT RESIDENT  
2001 W 64TH LN  
DENVER CO 80221-2345

CURRENT RESIDENT  
6521 CLAY ST LOT 35  
WESTMINSTER CO 80221-2336

CURRENT RESIDENT  
6540 CLAY ST APT A  
DENVER CO 80221-2361

CURRENT RESIDENT  
6521 CLAY ST LOT 37  
WESTMINSTER CO 80221-2336

CURRENT RESIDENT  
6540 CLAY ST APT B  
DENVER CO 80221-2361

CURRENT RESIDENT  
6550 CLAY ST APT A  
WESTMINSTER CO 80221-2363

CURRENT RESIDENT  
6550 CLAY ST APT B  
WESTMINSTER CO 80221-2363

CURRENT RESIDENT  
6521 CLAY ST LOT 36  
DENVER CO 80221-2364

CURRENT RESIDENT  
2611 W 64TH AVE UNIT B  
DENVER CO 80221-2368

CURRENT RESIDENT  
2611 W 64TH AVE UNIT C  
DENVER CO 80221-2368

CURRENT RESIDENT  
2611 W 64TH AVE UNIT E  
DENVER CO 80221-2368

CURRENT RESIDENT  
2611 W 64TH AVE UNIT G  
DENVER CO 80221-2368

CURRENT RESIDENT  
2376 W 67TH DR  
DENVER CO 80221-2623

CURRENT RESIDENT  
6701 ZUNI ST  
DENVER CO 80221-2698

# CERTIFICATE OF POSTING



I, J. Gregory Barnes do hereby certify that I posted the subject property at 2525 West 65<sup>th</sup> Place on January 12, 2021 in accordance with the requirements of the Adams County Development Standards and Regulations.

---

**J. Gregory Barnes**



# Burke Rezoning

RCU2020-00026  
2525 West 65<sup>th</sup> Place

February 23, 2021

Board of County Commissioners Public Hearing  
Community and Economic Development Department  
Case Manager: Greg Barnes

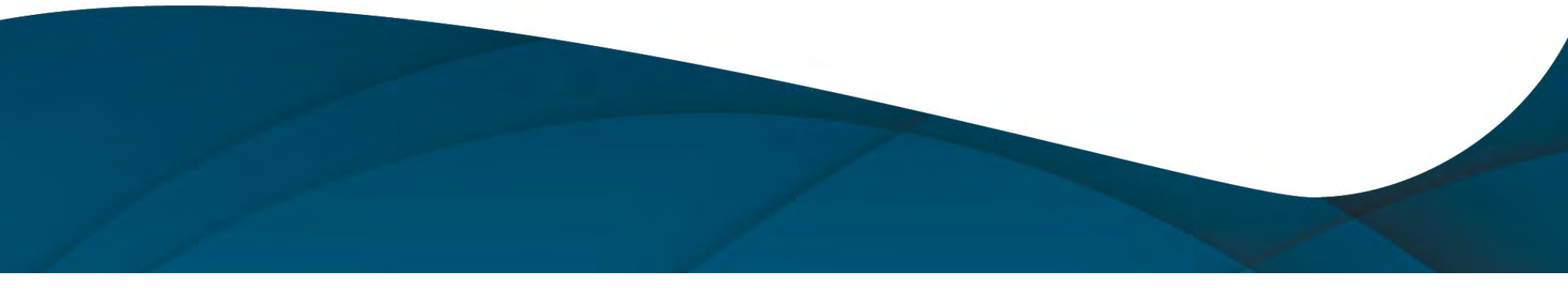

# Rezoning Summary

- Current Zoning: Residential-2
- Proposed Zoning: Residential-3
- Lot Size: 0.4 ac. / 17,860 sf

# AERIAL MAP

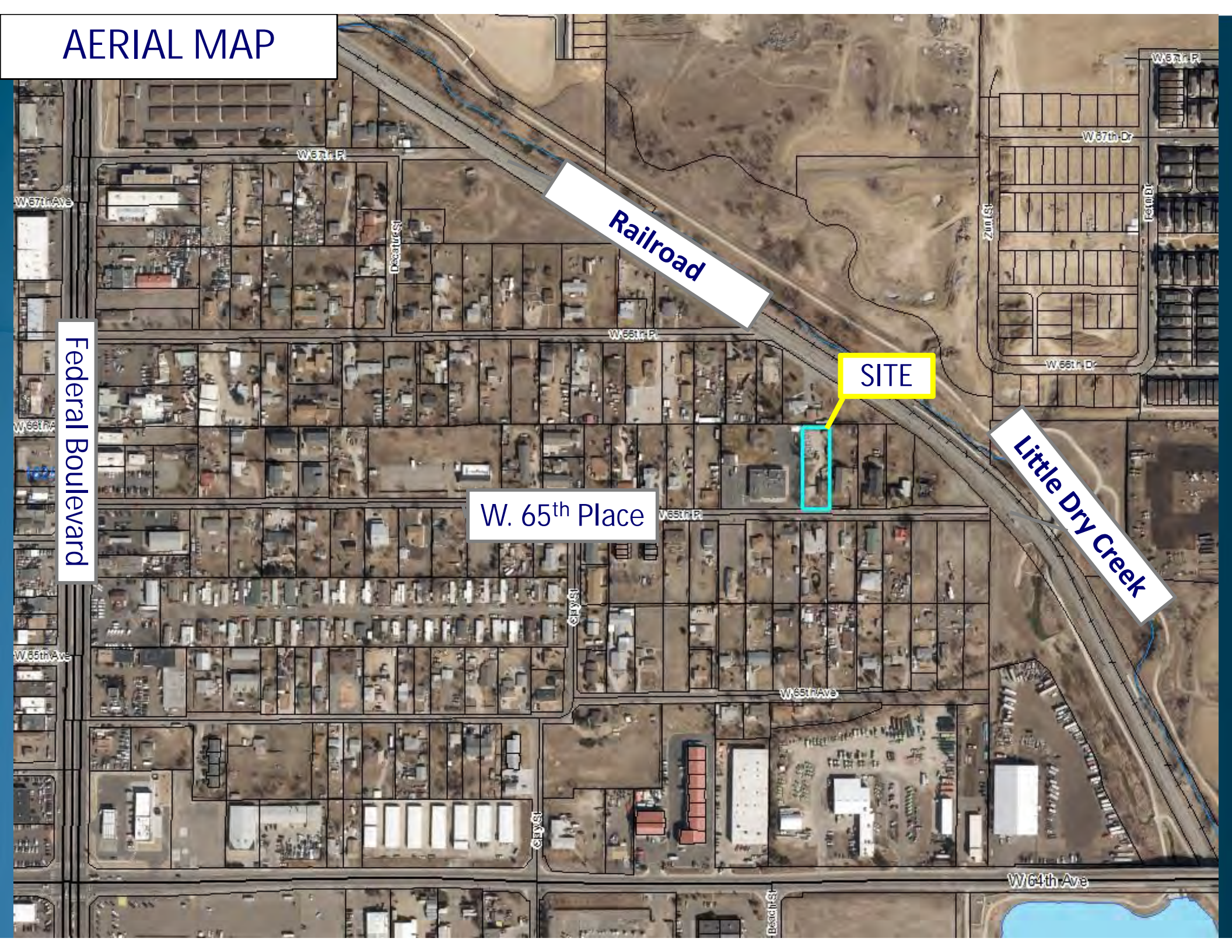

Railroad

SITE

W. 65th Place

Little Dry Creek

Federal Boulevard

W 67th Pl

W 67th Pl

W 67th Dr

W 67th Ave

Decatur St

2nd St

3rd St

W 65th Pl

W 65th Dr

W 66th Ave

W 65th Ave

4th St

W 65th Pl

W 65th Ave

5th St

Board St

W 64th Ave

# AERIAL MAP

Railroad

Little Dry Creek

SITE

W. 65<sup>th</sup> Place

W 55th Pl



# ZONING MAP

SITE: R-2 to R-3  
(Residential-2 to Residential-3)

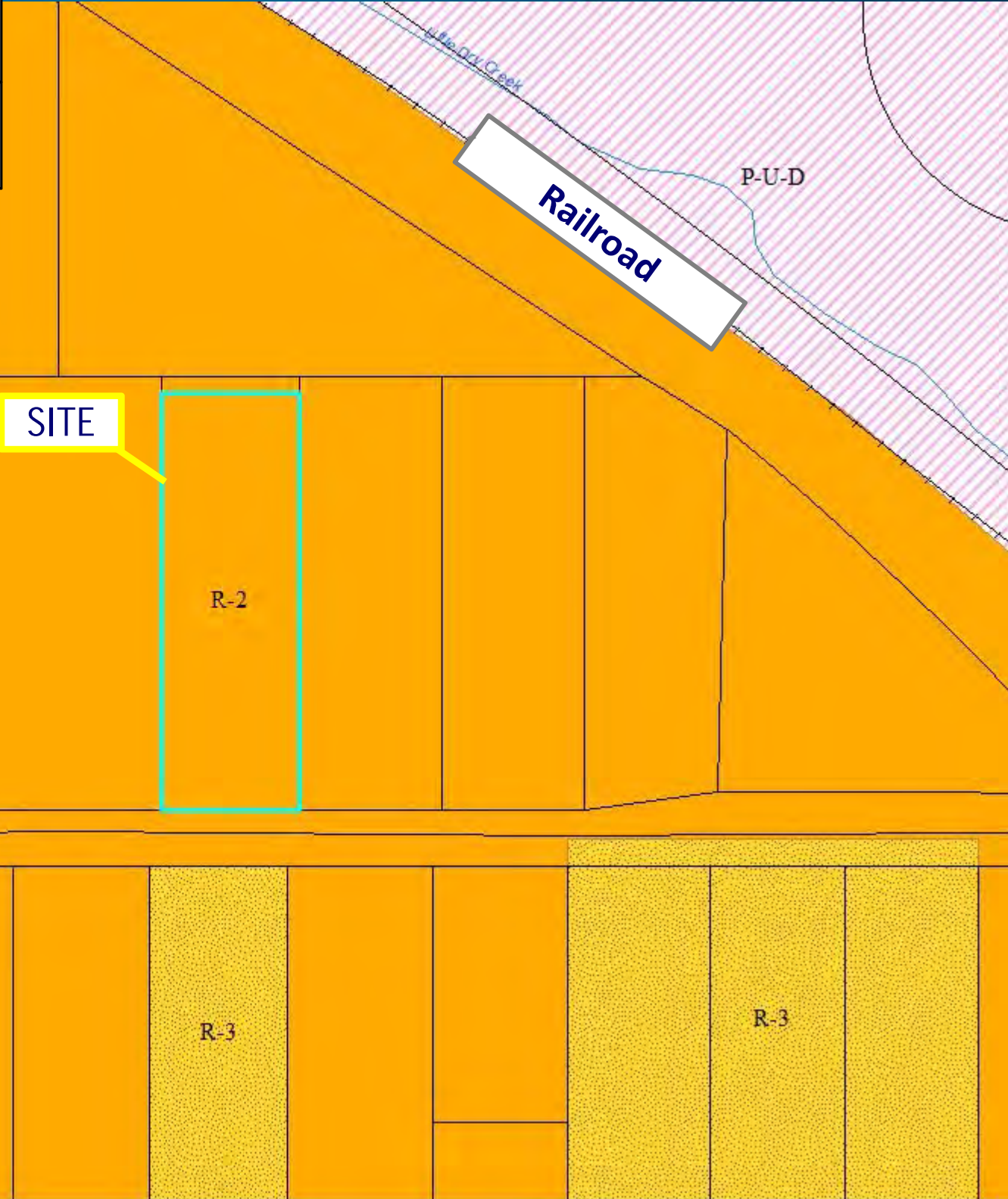

# FUTURE LAND USE MAP

SITE: Urban Residential

SITE

Railroad

Residential

W. 65<sup>th</sup> Place

W 65th Pl

Little Dry Creek



# Comprehensive Planning

The Balanced Housing Plan (2018) which identifies triplex products as part of the solution for missing middle housing type, which encompasses smaller scale housing solutions such as accessory dwelling units, duplex, triplex, and four-plex.

# Criteria of Approval

Section 2-02-15-06-02

1. Consistent with Comprehensive Plan
2. Consistent with purpose of Development Standards
3. Complies with Development Standards
4. Compatible with Surrounding Area



# Development Standards Residential-3 District (R-3)

- Minimum Lot Size
  - 2,500 sq. ft. per dwelling unit
  - Max. Density of 14 du/ac
    - (Max. 5 dwellings on this lot)
  - Multi-Family is Permitted, Duplex is Conditional
- Minimum Lot Width
  - 150 feet, measured at minimum front setback
  - Variance approved due to unique lot depth





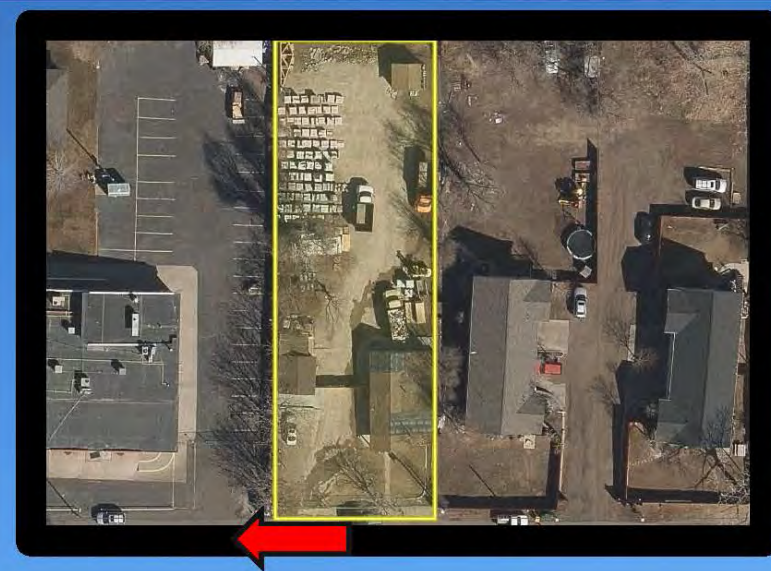

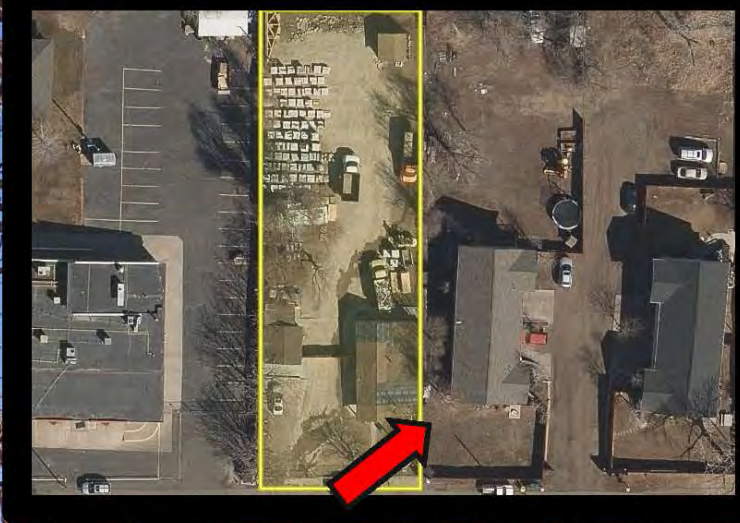
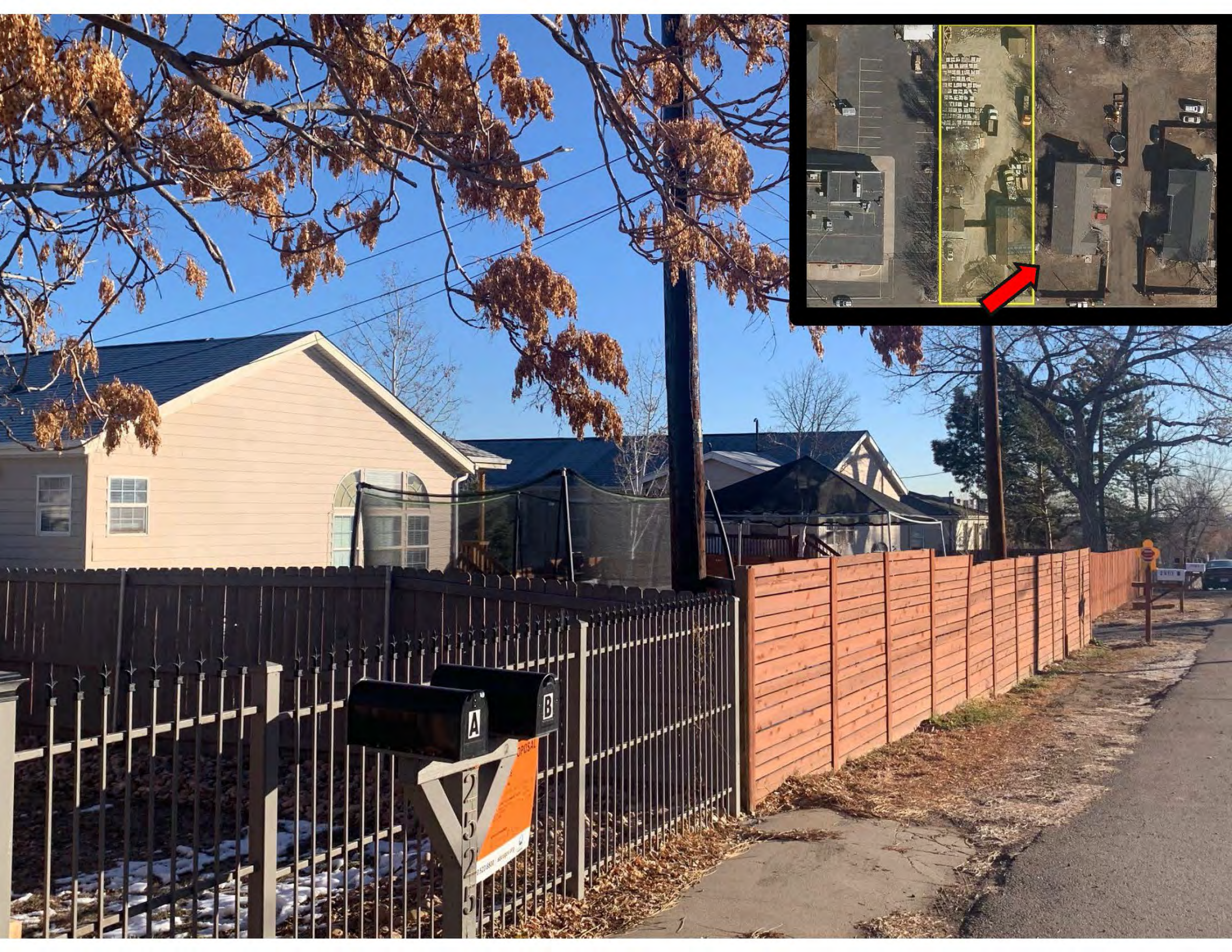



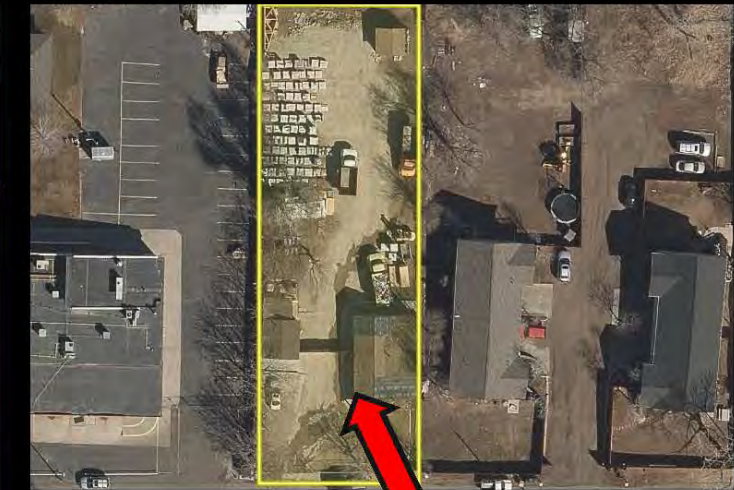





# Referral Period

Notices Sent	Comments Received
269	3

Property owners and residents within 1,000 feet notified

One comment generally supportive

- Increased housing supply

Two comments in opposition

- Preference for single-family and two-family dwellings

## REFERRAL AGENTS

Sheriff's office identified concern for providing services

No other referral agency objections

# Planning Commission Update

- Public Hearing: January 28, 2021
- No public comments provided at the hearing
- Staff Summarized:
  - Consistent with Future Land Use of Comprehensive Plan
  - Supports Balanced Housing Plan
  - Complies with Development Standards & Regulations
  - R-3 Zoning is compatible with Surrounding Area
- Recommended Approval (7-0)

# Staff and PC Recommendation

Approval of rezoning case # RCU2020-00026, Burke,  
with 4 Findings-of-Fact.

LOT WIDTH



LOT WIDTH





COMMUNITY AND ECONOMIC DEVELOPMENT  
DEPARTMENT

**CASE NO.: RCU2020-00038**

**CASE NAME: StreetMedia 6612 York St. Billboard CUP**

**TABLE OF CONTENTS**

**EXHIBIT 1 – BoCC Staff Report**

**EXHIBIT 2- Maps**

- 2.1 Aerial Map
- 2.2 Zoning Map
- 2.3 Future Land Use Map
- 2.4 Simple Map

**EXHIBIT 3- Applicant Information**

- 3.1 Applicant Written Explanation
- 3.2 Applicant Site Plan

**EXHIBIT 4- Referral Comments**

- 4.1 Referral Comments (Adams County)
- 4.2 Referral Comments (Adams County Fire and Rescue)
- 4.3 Referral Comments (CDOT)
- 4.4 Referral Comments (TCHD)
- 4.5 Referral Comments (XCEL)

**EXHIBIT 5- Public Comments**

No Public Comment

**EXHIBIT 6- Associated Case Materials**

- 6.1 Request for Comments
- 6.2 Public Hearing Notice
- 6.3 Newspaper Publication
- 6.4 Referral Agency Labels
- 6.5 Property Owner Labels
- 6.6 Certificate of Posting



**COMMUNITY AND ECONOMIC DEVELOPMENT  
DEPARTMENT  
STAFF REPORT**

**Board of County Commissioners**

**February 23, 2021**

<b>CASE No.: RCU2020-00038 CASE NAME: StreetMedia 6612 York St. Billboard CUP</b>	
Owner's Name:	Euro. LLLC
Applicant's Name:	Gary Young, Street Media Group, LLC
Applicant's Address:	161 Saturn Drive Unit 5A Fort Collins, CO 80229
Location of Request:	6612 York Street, Denver, Colorado 80221
Nature of Request:	Conditional Use Permit to allow an off-premise electronic sign (billboard).
Zone District:	Commercial-5 (C-5)
Future Land Use:	Industrial
Site Size:	.907 Acres
Proposed Use:	Industrial/ Electronic Billboard
Existing Use:	Vacant
Hearing Date(s):	<b>PC: January 28, 2021 / 6:00 pm</b> <b>BoCC: February 23, 2021 / 9:30 am</b>
Report Date:	February 3, 2021
Case Manager:	Layla Bajelan
Staff Recommendation:	Staff recommends APPROVAL of the subject request WITH the applicants request for a variation in the setback, with 8 Findings-of-Fact, 6 Conditions, and 3 Notes to the applicant.

**SUMMARY OF APPLICATION**

**Background:**

The applicant, Gary Young of Street Media Group, is requesting a conditional use permit to allow for an off-premise electronic sign (billboard) in the Commercial-5 (C-5) zone district. The property is currently undeveloped.

**Site Characteristics:**

The subject property is zoned as Commercial-5 (C-5) and is .907 acres. The parcel has frontage along Columbine Street. Currently the site is undeveloped, and the parcel is visible from both the north and south bound lanes of the Highway 270. The billboard is proposed to be located roughly

28 feet from the western and northern property lines and 30 feet from the southern property line in the southwest corner of the parcel.

**Development Standards and Regulations:**

The property is zoned Commercial-5 (C-5). Per Section 3-23-01 of the County’s Development Standards and Regulations, the purpose of the Commercial-5 District is to serve as a general retail and service district designed to provide the broadest scope of services and products for both the general and traveling public in an interstate and regional context. In certain situations, it may be appropriate through a conditional use permit to allow a mix of uses in this zone district – allowing both residential and commercial uses within one building. Off-premise advertising devices are permitted with an approved Conditional Use Permit in the C-5 and all industrial zone districts.

Section 4-16 of the County’s Development Standards and Regulations outlines the required design and performance standards for billboards, which includes standards for electronic signs. These standards ensure outdoor advertising devices are properly located to minimize visual and physical impacts to surrounding properties. Required design standards include: maximum height, maximum sign area, number of billboards allowed per lot, minimum setbacks from property lines, and minimum spacing from other off-premise signs.

The applicant has submitted a site plan and elevation drawings with the subject request. The proposed billboard is 32-feet in height. Per section 4-16-05, the height shall be determined as the distance from the grade of the right-of-way on which the sign fronts to the top of the sign including all projections. In this instance the adjacent right-of-way is Columbine Street, which sits at the same elevation as the subject site.

The proposed sign has two advertising faces, with each being three hundred (300) square feet per sign face. The proposed height and size of the billboard conforms to the County’s required maximum height of 40 feet and maximum sign area of 300 square feet for each single sign face. When an off-premise sign has two faces arranged in a V-shape, the faces shall be: a maximum of 45 degrees at the interior angle, or a maximum of 15 feet apart at its widest point, whichever is less. The applicant has demonstrated the billboard shows compliance with this requirement.

Section 4-16-07 of the County’s Development Standards and Regulations outlines other limitations for off-premise signs. The minimum right-of-way and property line setback requirements shall be equal to the height of the billboard, as measured from the leading edge of the sign face. Variations in the setback requirement may be granted with the issuance of a Conditional Use Permit. The proposed billboard is 32 feet in height, so all setbacks would be required to be a minimum of 32 feet. The applicant is requesting a variation in the setback of the subject off-premise sign to allow for a 28 feet from the western and northern property lines and 30-feet from the southern property.

Previous billboard applications have been granted the setback variation with the condition that the proposed billboard be built to Category 3 Building Code. Staff feels that the extra safety requirements added with the Category 3 Building Code requirements effectively address any



safety concerns of the billboard falling over or causing harm to nearby property owners and residents. The same requirement will be added to this case as a condition of approval.

Per Section 4-16-03 of the County's Development Standards and Regulations, only one off-premise sign is permitted per lot. In addition, all off-premise signs located on the same side of a road or highway shall be separated by a minimum of 2,000 linear feet. The proposed billboard will be the only billboard permitted on the property and the applicant has provided documentation demonstrating that no billboards are within 2,000 linear feet of the subject site.

Per Section 4-16-06-02 of the County's Development Standards and Regulations, an electronic sign is permitted as part of a billboard. Performance standards for electronic signs include duration of message, transition of message, prohibited electronic devices, and maximum brightness. According to the Development Standards and Regulations, each message displayed shall remain static for a minimum of four seconds, with 10 seconds being optimal, and must transition immediately to the next message displayed. All such signs shall have a default mode to prevent the display from malfunctioning in a flashing or intermittent fashion. In accordance with Section 4-16-06-02 of the County's Development Standards and Regulations, electronic devices shall not display animated images or graphics, scrolling messages, videos, or emit audible sounds. In addition, each sign shall be equipped with light monitors and controls that automatically adjust to environmental/outside conditions. According to the applicant, the proposed billboard will conform to all electronic sign performance standards. Messages will change every seven (7) seconds with a transition of less than one (1) second to the next message. The sign will display only static messages and will be equipped with auto-dimming technology to reduce intensity of light as ambient light decreases.

In addition to the Adams County Development Standards and Regulations, the proposed billboard must show compliance with all the requirements of the Colorado Outdoor Advertising Act, C.R.S. 43-1-401 et. Seq. and the Colorado rules and regulations promulgated thereunder by the Colorado Department of Transportation.

**Future Land Use Designation/Comprehensive Plan:**

The future land use designation on the property is Industrial. Per Chapter 5 of the Adams County Comprehensive Plan, the purpose of the Industrial areas is to provide a setting for a wide range of employment uses, including manufacturing, warehouses, distribution, and other industries. These areas may also include limited supporting uses such as retail and outdoor storage. Key considerations at the edges of industrial areas include limiting or buffering noise, vehicle, appearance, and other impacts of industrial uses on nearby non-residential uses. The proposed billboard would be an accessory use on a property, if developed. Therefore, it is unlikely that this request has any impact on the future goals of the County in this area.

The recommendation of approval for the subject billboard is based strictly on the criteria of approval for a Conditional Use Permit; however, it is important to discuss the project's compliance with the applicable subarea plans. The Comprehensive Plan and its adopted subarea plans are intended to provide guidance for future development within the County. The subject parcel is located within the Southwest Area Framework Plan. The Southwest Area Framework

Plan is an adopted plan in the Comprehensive plan. The plan includes a Policy 14.7 to *Enhance the area’s role as an important County Gateway*. Strategies in completing the goals include:

1. 14.7.a. *Entryway Image* – Initiate landscaping, streetscaping, and buffering programs to improve the entryway image of the County as viewed from I-70, I-25, and I-76 and key highway exits into the County;
2. 14.7.b. *Screening and Buffering* – Require improved buffering for new development along the I-70, I-25, and I-76 corridors, and require screening for new outdoor storage and activities visible from I-70, I-25, and I-76; and
3. 14.7.c *Signs* – Review and update the sign regulation provisions, including control of off-premise signs, applicable to private lands visible from I-70, I-25, and I-76 and key highway exits into the County.

Strategy 14.7.c suggests that the County should update the sign code to potentially control the number of off-premise signs permitted along gateways into Adams County. The plan also suggests that setbacks and buffers from I-25 and I-76 should be greater than in other areas of the County.

**Surrounding Zoning Designations and Existing Use Activity:**

<b>Northwest Highway-270</b>	<b>North Industrial-2 Water Storage Pond</b>	<b>Northeast Agriculture-1 Vacant</b>
<b>West Highway-270</b>	<b>Subject Property Commercial-5 Vacant</b>	<b>East Agriculture-1 Vacant</b>
<b>Southwest Highway-270</b>	<b>South Agriculture-1 Vacant</b>	<b>Southeast Agriculture-1 Vacant</b>

**Compatibility with the Surrounding Area:**

The surrounding properties are all zoned as Industrial-2 or Agriculture-1 and are primarily vacant. To the north of the subject parcel is a water storage pond that is owned by the City and County of Denver. Highway-270 is located roughly 72 feet to the west of the subject parcel. The South Platte River is located roughly 325 feet to the west of the subject parcel.

**PC Update**

The Planning Commission (PC) considered the case on January 28, 2021 and voted (6-1) to recommend APPROVAL of the subject request WITH the applicants request for a variation in the setback, with 8 Findings-of-Fact, 6 Conditions, and 3 Notes to the applicant. The applicant spoke at the meeting and had no concerns with the staff report of the presentation. There was no one from the public to speak in favor or in opposition to this request. The Planning Commission had several questions in regard to the current uses on the property, the transition timing of the billboard, and if landscaping could be added with this request.

**Staff Recommendation:**

Based upon the application, the criteria for approval of a Conditional Use Permit, and a recent site visit, Staff recommends APPROVAL of the subject request WITH the applicant's request for a variation in the setback, with 8 Findings-of-Fact, 6 Conditions, and 3 Notes to the applicant.

**RECOMMENDED FINDINGS-OF-FACT**

1. The conditional use is permitted in the applicable zone district.
2. The conditional use is consistent with the purposes of these standards and regulations.
3. The conditional use will comply with the requirements of these standards and regulations, including but not limited to, all applicable performance standards.
4. The conditional use is compatible with the surrounding area, harmonious with the character of the neighborhood, not detrimental to the immediate area, not detrimental to the future development of the area, and not detrimental to the health, safety, or welfare of the inhabitants of the area and the County.
5. The conditional use permit has addressed all off-site impacts.
6. The site is suitable for the proposed conditional use including adequate usable space, adequate access, and absence of environmental constraints.
7. The site plan for the proposed conditional use will provide the most convenient and functional use of the lot including the parking scheme, traffic circulation, open space, fencing, screening, landscaping, signage, and lighting.
8. Sewer, water, storm water drainage, fire protection, police protection, and roads are available and adequate to serve the needs of the conditional use as designed and proposed.

**Recommended Conditions of Approval:**

1. The applicant must show compliance with all the requirements of the Colorado Outdoor Advertising Act, C.R.S. 43-1-401 et. Seq. and the Colorado rules and regulations promulgated thereunder by the Colorado Department of Transportation.
2. The applicant shall obtain an Outdoor Advertising Permit from the Colorado Department of Transportation.
3. The applicant shall obtain a building permit from Adams County for the billboard, including all required building permit inspections.
4. Each message displayed on the billboard shall remain static for a minimum of four (4) seconds and must transition immediately to the next message displayed.
5. The approval of the off-premise sign shall expire February 23, 2031 unless renewed.
6. The Applicant shall build the billboard to a Category Three Building Code standard, which will be reviewed at the time of Building Permit application.

**Recommended Notes to the Applicant:**

1. All applicable building, zoning, health, fire, and engineering requirements and codes shall be adhered to with this request. The applicant may submit an alternative design that can be approved through a Minor Amendment to this Conditional Use Permit by staff, as

long as the design complies with the Adams County Development Standards and Regulations at the time of building permit application.

2. The conditional use permit shall expire on February 23, 2022 if sign permits are not obtained from Adams County.
3. Any sign or attractive device which includes animated images or graphics, scrolling messages, video, moving images similar to television images, emits audible sounds, employs stereopticon, or includes motion picture projection is prohibited.

**CITIZEN COMMENTS**

Notifications Sent	Comments Received
18	0

All property owners and occupants within 1,000 feet of the subject property were notified of the request. As of writing this report, staff has not received any public comment regarding this case.

**REFERRAL AGENCY COMMENTS**

Staff notified several Referral Agencies throughout this process and no concerns were identified.

**Responding with Concerns:**

N/A

**Responding without Concerns:**

Colorado Department of Transportation  
 Tri-County Health Department (TCHD)  
 Xcel Energy

**Notified but not Responding / Considered a Favorable Response:**

Adams 12 Five Star Schools  
 Adams County Sheriff  
 Adams County Treasurer  
 Adams County Fire Protection District  
 Adams County School District 14  
 Berkeley Water  
 Colorado Department of Public Health and Environment (CDPHE)  
 Century Link, Inc.  
 City of Commerce City  
 City of Thornton  
 Colorado Division of Wildlife  
 Comcast  
 Crestview Water and Sanitation District  
 Mapleton School District #1  
 Metro Wastewater Reclamation  
 Neighborhood Improvement Committee  
 North Lincoln Water and Sanitation District

North Pecos Water and Sanitation District  
North Washington Street Water and Sanitation District  
Perl Mack Neighborhood Group  
Regional Transportation District (RTD)  
South Adams County Fire District  
South Adams County Water and Sanitation District  
Union Pacific Railroad  
Welby Citizen Group  
Westminster School District #50



**Legend**

- +— Railroad
- Major Water
- Zoning Line
- Sections
- Zoning Districts**
- A-1
- A-2
- A-3
- R-E
- R-1-A
- R-1-C
- R-2
- R-3
- R-4
- M-H
- C-0
- C-1
- C-2
- C-3
- C-4
- C-5
- I-1
- I-2
- I-3
- CO
- PL
- AV
- DIA
- P-U-D
- P-U-D(P)
- Conditions

**RCU2020-00038; 6612 York Street Billboard CUP**

**Aerial Map**



For display purposes only.



This map is made possible by the Adams County GIS group, which assumes no responsibility for its accuracy



**Legend**

- +— Railroad
- Major Water
- Zoning Line
- Sections

1825

270

**RCU2020-00038; 6612 York Street Billboard CUP**

**Aerial Map**



For display purposes only.



This map is made possible by the Adams County GIS group, which assumes no responsibility for its accuracy

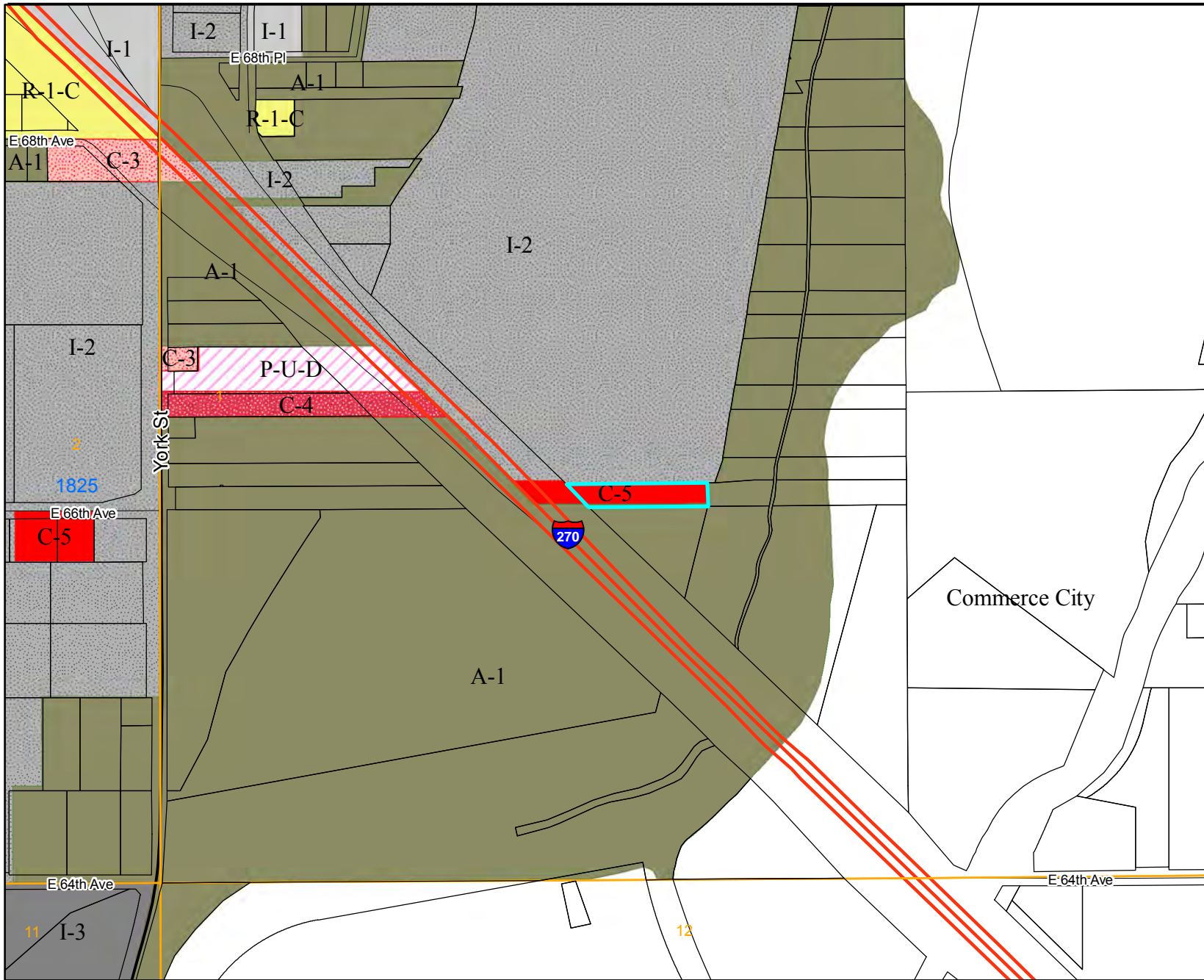

**Legend**

- Railroad
- Major Water
- Zoning Line
- Sections
- Zoning Districts**
- A-1
- A-2
- A-3
- R-E
- R-1-A
- R-1-C
- R-2
- R-3
- R-4
- M-H
- C-0
- C-1
- C-2
- C-3
- C-4
- C-5
- I-1
- I-2
- I-3
- CO
- PL
- AV
- DIA
- P-U-D
- P-U-D(P)
- Conditions

Commerce City

**RCU2020-00038; 6612 York Street Billboard CUP**

**Aerial Map**



For display purposes only.



This map is made possible by the Adams County GIS group, which assumes no responsibility for its accuracy





**Legend**

- +— Railroad
- Major Water
- Zoning Line
- Sections

**Zoning Districts**

**Legend**

**Future Landuse 2012 (Rev2016)**

- Residential**
  - Urban Residential
  - Estate Residential
- Mixed Use**
  - Local District Mixed Use
  - Mixed Use Neighborhood
  - Activity Center
  - Mixed Use Employment
- Commercial/Industrial**
  - Commercial
  - Industrial
- Other**
  - Agriculture
  - DIA Reserve
  - Parks and Open Space
  - Public
  - Municipal Area

Conditions

**RCU2020-00038; 6612 York Street Billboard CUP**

**Future Land Use Map**



For display purposes only.



This map is made possible by the Adams County GIS group, which assumes no responsibility for its accuracy

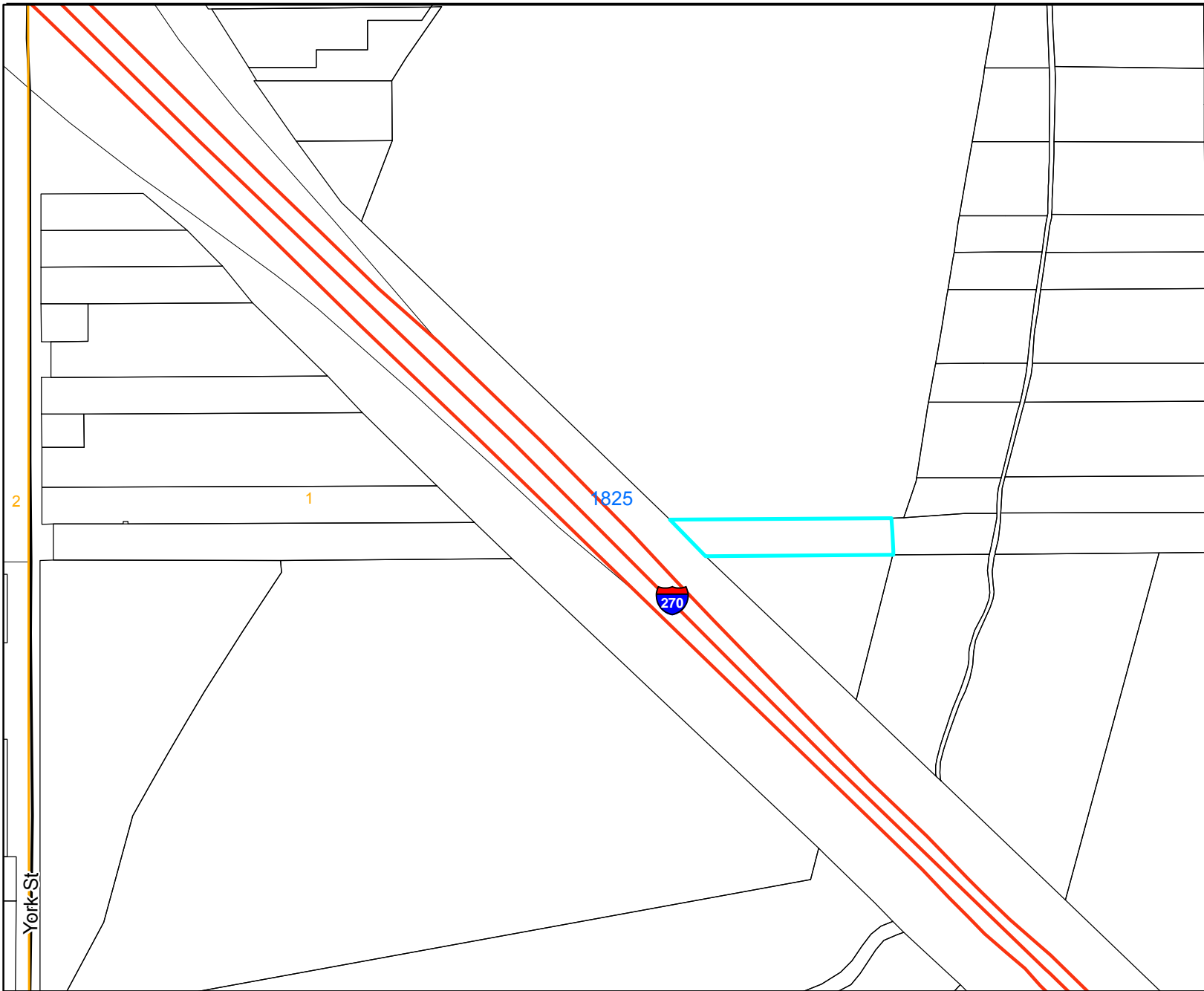

**Legend**

- +— Railroad
- Major Water
- Zoning Line
- Sections
- Zoning Districts**
- A-1
- A-2
- A-3
- R-E
- R-1-A
- R-1-C
- R-2
- R-3
- R-4
- M-H
- C-0
- C-1
- C-2
- C-3
- C-4
- C-5
- I-1
- I-2
- I-3
- CO
- PL
- AV
- DIA
- P-U-D
- P-U-D(P)
- Conditions

RCU2020-00038; 6612 York Street

Simple Map



For display purposes only.



This map is made possible by the Adams County GIS group, which assumes no responsibility for its accuracy

APPLICATION FOR CONDITIONAL USE PERMIT APPROVAL  
FOR OFF-PREMISE ADVERTISING DEVICE (BILLBOARD)

Applicant: StreetMedia Group, LLC  
Location: 6612 York Street

**WRITTEN EXPLANATION OF THE PROJECT**

StreetMedia Group proposes to conduct an off-premise advertising device (billboard) 6612 York Street, which is generally located northeast of I-270, south of I-76, and east of York Street (“SUBJECT PROPERTY”) (PIN 0182501303023) in the location shown on the enclosed site plan. The Subject Property is approximately 0.907 acres in area and is zoned C-5 (“DISTRICT”). The Subject Property has no vertical improvements, and is currently used for outdoor storage.

Billboards are allowed in the District with an approved Conditional Use Permit (“CUP”). CUPs are subject to the approval criteria set out in Section 2-02-09-06, Adams County Development Standards and Regulations (“ADCO STANDARDS”). Billboard performance standards are set out in ADCO Standards § 4-15. No other ADCO Standards apply during the conditional use permit process.

The proposed billboard complies with all applicable CUP and performance standards, as follows:

**CUP STANDARD #1.** THE CONDITIONAL USE IS PERMITTED IN THE APPLICABLE ZONE DISTRICT. Billboards are allowed as a conditional use in the District.

**CUP STANDARD #2.** THE CONDITIONAL USE IS CONSISTENT WITH THE PURPOSES OF [THE ADCO STANDARDS].

The proposed billboard is allowed as a conditional use in the District. The proposed billboard meets all applicable performance standards. As such, it is consistent with the purposes of the ADCO Standards.

**CUP STANDARD #3.** THE CONDITIONAL USE WILL COMPLY WITH THE REQUIREMENTS OF [THE ADCO STANDARDS], INCLUDING, BUT NOT LIMITED TO, ALL APPLICABLE PERFORMANCE STANDARDS.

The proposed billboard complies with the requirements of ADCO Standards § 4-15, which set out the performance standards for billboards, as follows:

STANDARD	COMPLIANCE STATEMENT
4-15-03	The Subject Property will contain only one billboard with not more than two faces.
4-15-04	The area of each sign face will not exceed 300 square feet.
4-15-05	The height of the proposed sign is 28 feet, measured as provided in ADCO Standards § 4-15-05.

STANDARD	COMPLIANCE STATEMENT
4-15-06-02	Messages displayed on the electronic sign faces will remain static for a minimum of four seconds per message and instantaneous transitions will be used from one message to the next. The electronic sign faces will have a default mode to turn off the display if it malfunctions. The electronic sign faces will have automatic dimmers and will comply with the County’s brightness standards.
4-15-07 #1	The sign is separated from off-premises signs on the same side of the highway a distance that exceeds the 2,000 foot minimum spacing set out in Section 4-15-07 #1, ADCO Standards. By separate letter, the applicant has withdrawn a nearby application numbered RCU2020-00015.
4-15-07 #2	The leading edge of the sign face is set back from all property lines a distance equal to the height of the billboard (28 feet).
4-15-07 #3	Acknowledged
4-15-07 #4	Acknowledged
4-15-07 #5	This item is a restatement of requirements in ADCO Standards § 4-15-06-02. See response provided to said standards, above.
4-15-07 #6	As shown on the attached site plan, the sign faces will have a “V” configuration with an interior angle of less than 45 degrees, and a maximum distance between sign faces of 15 feet or less.
4-15-07 #7	Acknowledged

**CUP STANDARD #4.** THE CONDITIONAL USE IS COMPATIBLE WITH THE SURROUNDING AREA, HARMONIOUS WITH THE CHARACTER OF THE NEIGHBORHOOD, NOT DETRIMENTAL TO THE IMMEDIATE AREA, NOT DETRIMENTAL TO THE FUTURE DEVELOPMENT OF THE AREA, AND NOT DETRIMENTAL TO THE HEALTH, SAFETY, OR WELFARE OF THE INHABITANTS OF THE AREA AND THE COUNTY. IN MAKING THIS DETERMINATION, THE PLANNING COMMISSION AND THE BOARD OF COUNTY COMMISSIONERS SHALL FIND, AT A MINIMUM, THAT THE CONDITIONAL USE WILL NOT RESULT IN EXCESSIVE TRAFFIC GENERATION, NOISE, VIBRATION, DUST, GLARE, HEAT, SMOKE, FUMES, GAS, ODORS, OR INAPPROPRIATE HOURS OF OPERATION.

The proposed billboard would be located between Cat Lake and the Miller Reservoir, along an interstate highway corridor that includes a mix of vacant land and industrial uses. By way of example, just across I-270 from the subject property is the Metro Wastewater Reclamation District Robert W. Hite Wastewater Treatment Facility and the Suncor Refinery, two of the largest “heavy industries” for miles. The sign is either consistent with or an upgrade to the industrial character of the area in which it is located. It will allow for not only advertising space, but also for “help wanted,” public service, and emergency messaging. As such, it advances the health, safety, and welfare of the inhabitants of the area, the County, and the region.

The sign is located in an area of heavy traffic, noise, smoke, fumes, gas, and odors, but it will not add to those hazards in any way. In fact, the sign will produce no additional traffic, noise, vibration, heat, smoke, fumes, gas, or odors. Light emissions from the sign during nighttime hours will be in compliance with Colorado Department of Transportation (“CDOT”) and Adams County standards.

**CUP STANDARD # 5.** THE CONDITIONAL USE PERMIT HAS ADDRESSED ALL OFF-SITE IMPACTS. The sign will comply with all applicable lighting requirements of the County and CDOT, and will be constructed to building code requirements. The sign is located outside of sight distance triangles. As such, it does not create off-site impacts.

**CUP STANDARD #6.** THE SITE IS SUITABLE FOR THE CONDITIONAL USE INCLUDING ADEQUATE USABLE SPACE, ADEQUATE ACCESS, AND ABSENCE OF ENVIRONMENTAL CONSTRAINTS. The Subject Property is suitable for the proposed billboard. The existing use of the Subject Property is principally outdoor storage. There is room on the Subject Property to include the proposed billboard without interference with the existing use. There are no environmental constraints on the Subject Property that would interfere with the proposed billboard.

**CUP STANDARD #7.** THE SITE PLAN FOR THE PROPOSED CONDITIONAL USE WILL PROVIDE THE MOST CONVENIENT AND FUNCTIONAL USE OF THE LOT INCLUDING THE PARKING SCHEME, TRAFFIC CIRCULATION, OPEN SPACE, FENCING, SCREENING, LANDSCAPING, SIGNAGE, AND LIGHTING. The attached site plan shows the sign placed in a location that provides for the functional use of the lot. The sign is optimized for safe view angles from the adjacent highway.

**CUP STANDARD #8.** SEWER, WATER, STORM WATER DRAINAGE, FIRE PROTECTION, POLICE PROTECTION, AND ROADS ARE TO BE AVAILABLE AND ADEQUATE TO SERVE THE NEEDS OF THE CONDITIONAL USE AS DESIGNED AND PROPOSED. The listed services are currently adequate to serve the principal use, and there will be no perceptible increase in demand for any of the listed services as a result of the installation of a billboard.



PROPERTY MAP

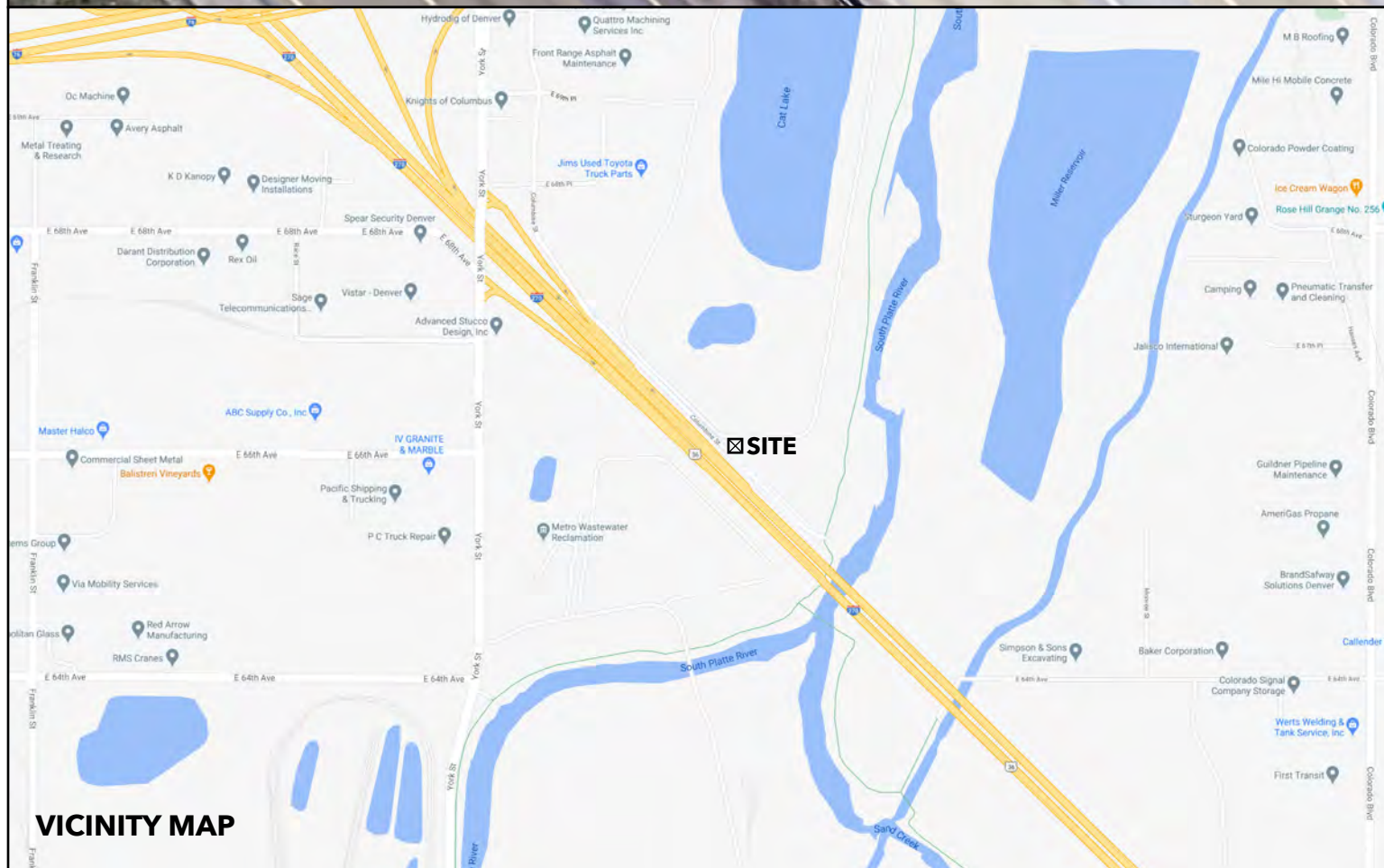

VICINITY MAP

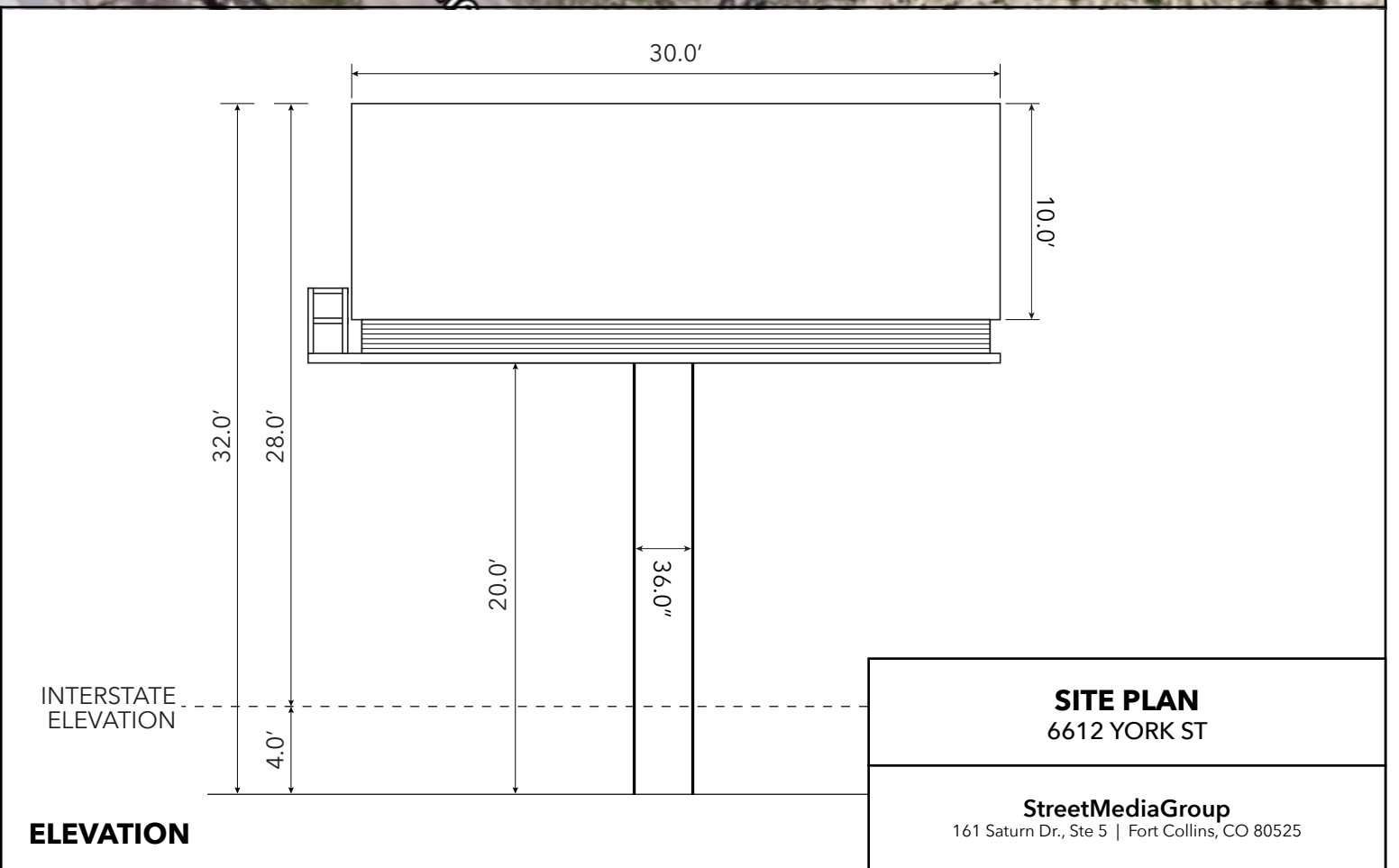

ELEVATION

**SITE PLAN**  
6612 YORK ST

**StreetMediaGroup**  
161 Saturn Dr., Ste 5 | Fort Collins, CO 80525

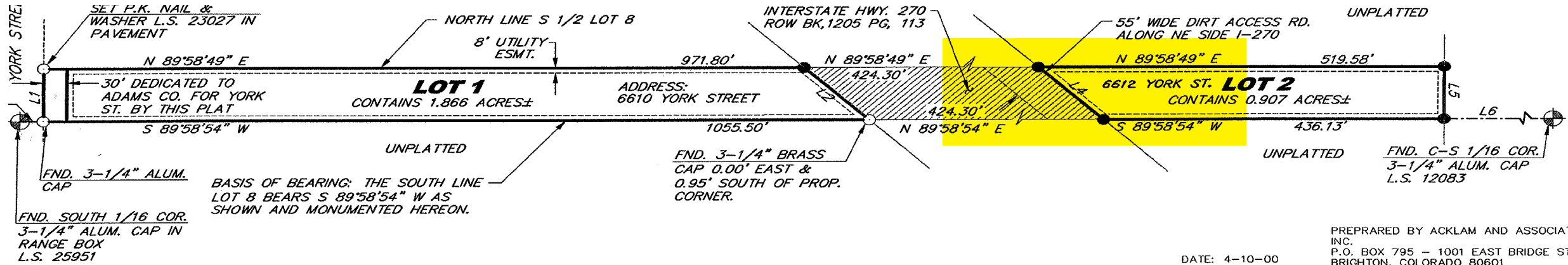
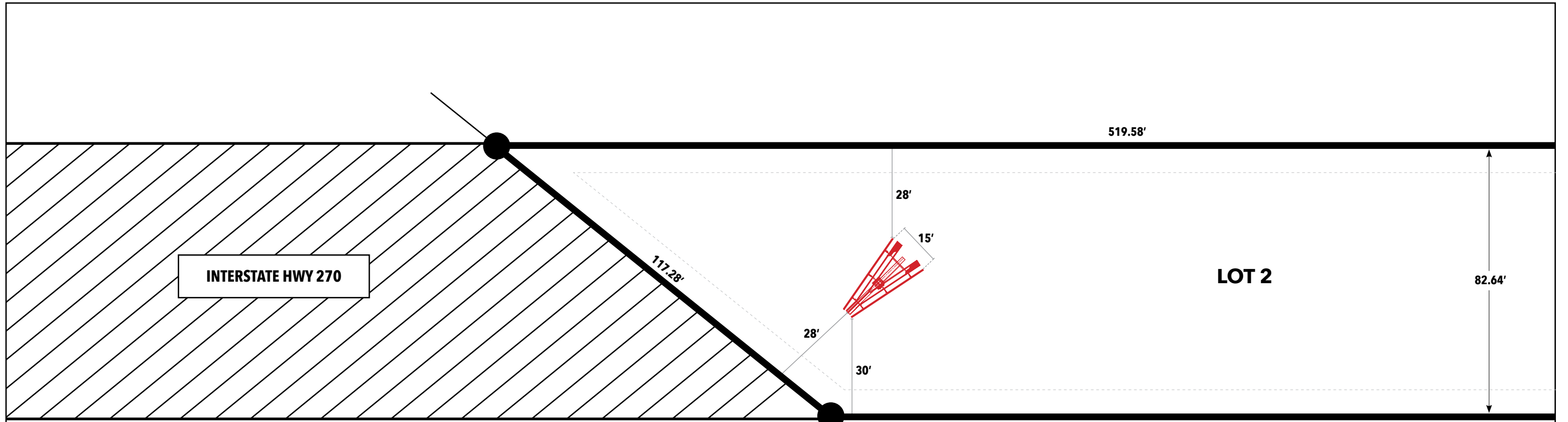

BASIS OF BEARING: THE SOUTH LINE LOT 8 BEARS S 89°58'54" W AS SHOWN AND MONUMENTED HEREON.

LINE	BEARING	DISTANCE
L1	N 00°18'29" E	82.60'
L2	S 45°13'42" E	117.28'
L3	S 89°58'54" W	30.00'
L4	N 45°13'42" W	117.28'
L5	S 00°08'08" W	82.64'
L6	N 89°58'54" E	705.00'

DATE: 4-10-00

PREPARED BY ACKLAM AND ASSOCIATES, INC.  
 P.O. BOX 795 - 1001 EAST BRIDGE STREET  
 BRIGHTON, COLORADO 80601  
 303-659-8546

**SITE PLAN**  
6612 YORK ST

---

**StreetMediaGroup**  
161 Saturn Dr., Ste 5 | Fort Collins, CO 80525

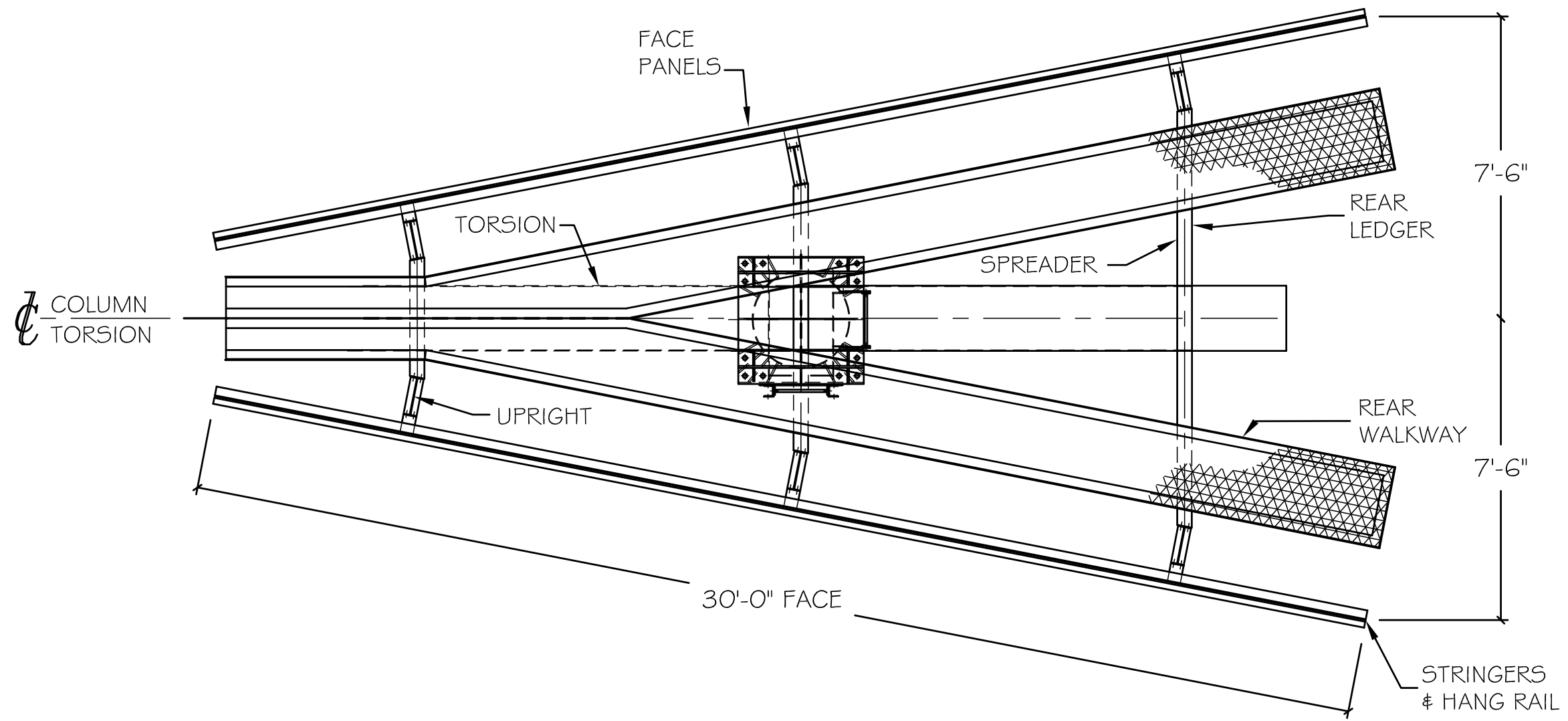

**SITE PLAN**  
6612 YORK ST

**StreetMediaGroup**  
161 Saturn Dr., Ste 5 | Fort Collins, CO 80525





**PROPOSED BILLBOARD**

**No existing billboards  
within 2,000 ft. in  
either direction**

**SITE PLAN**  
6612 YORK ST

**StreetMediaGroup**  
161 Saturn Dr., Ste 5 | Fort Collins, CO 80525



**PHOTOSIMULATION**  
6612 YORK ST

**StreetMediaGroup**  
161 Saturn Dr., Ste 5 | Fort Collins, CO 80525



**PHOTOSIMULATION**  
6612 YORK ST

**StreetMediaGroup**  
161 Saturn Dr., Ste 5 | Fort Collins, CO 80525



695ft  
0.0352fc

373ft  
0.123fc

744ft  
0.0211fc

360ft  
0.132fc

750ft  
0.8307fc





### Development Review Team Comments

**Date:** December 23, 2020  
**Project Number:** RCU2020-00038  
**Project Name:** 6612 York Street Billboard CUP

**Note to Applicant:**

The following review comments and information from the Development Review Team is based on the information you submitted for the Conditional Use Permit Application. The Development Review Team review comments may change if you provide different information during the Resubmittal. At this time, a resubmittal is not being required.

**Commenting Division:** Development Services, Planning  
**Name of Reviewer:** Layla Bajelan  
**Email:** [LBajelan@adcogov.org](mailto:LBajelan@adcogov.org) / 720-523-6863

**PLN01: Request**

Conditional Use Permit for an electronic billboard. The subject property is zoned as C-5 and is visible from Highway 270.

**PLN02: Site Characteristics**

- Address: 6612 York Street
- Current Zoning: C-5
- Future Land Use: Industrial
- Parcel Number: 0182501303023
- Legal Description: SUB:CHAPLINSKIY SUBDIVISION LOT:2
- Parcel Size: .9070 acres

**PLN03: Section 4-15 Off-Premise Advertising Devices (Billboard)**

1. 4-15-03 Maximum Number of Signs; Only one (1) two-faced off-premise advertising device shall be permitted per lot.
  - No other off-premise advertising devices exist or will be permitted on this lot, if this application is approved.
2. 4-15-04 Maximum Size; No off-premise advertising device shall exceed three hundred (300) square feet per face.
  - The subject billboard is proposed to be 30 x 10 feet (300 sq. ft.), which would conform to the regulations.

3. 4-15-05 Maximum Height and Minimum Clearance; No off-premise advertising device shall exceed forty (40) feet in height. Height shall be determined as the distance from the grade of the right-of-way on which the sign fronts to the top of the sign including all projections. If located within one thousand (1,000) feet of an intersection of two (2) or more public rights-of-way, the lowest point of the sign face(s) shall be at least eight (8) feet above the ground.
  - The subject billboard is proposed to be 32 feet tall.
  - Per an email sent to the applicant on 07/21/2020: "The County interprets this section to measure the height for an off-premise sign from the centerline of the adjacent right-of-way." In this case the adjacent ROW is Columbine Street and NOT the nearest interstate/highway. If the applicant would like the County to consider the 28 foot measurement, the applicant must submit a detailed engineering or land survey in order to verify the proposed measurement that is being used to verify the County's maximum height requirement. That survey should show the topography of the site and the adjacent right-of-way, as well as the differences in the height or the spot elevations of the grade of the internal site where the billboard is proposed to be placed vs. the grade of the adjacent right-of-way (Columbine Street).
  - Staff is not requiring the survey for this application, as the billboard does not exceed the 40 foot height limitation.

**PLN04: Section 4-15-06-02 Electronic Sign Restrictions; An electronic sign is permitted to be incorporated into an off-premise sign subject to the following restrictions:**

1. Duration of Message: Each message displayed shall remain static for a minimum of four (4) seconds, with ten (10) seconds optimal. All such signs shall have a default mode to prevent the display from malfunctioning in a flashing or intermittent fashion.
2. Transition of Message: Each message shall transition to the next message instantaneously.
3. Prohibited Electronic Signs: Any sign or attractive device which includes animated images or graphics, scrolling messages, video, moving images similar to television images, emits audible sound, employs stereopticon, or includes motion picture projection. Any sign or attractive device which displays its message or portion thereof for less than four (4) seconds before a change occurs shall be considered flashing or intermittent.
4. Brightness / Luminance: Electronic signs shall be equipped with and employ the use of light monitors and controls that allow sign brightness to automatically adjust to outside conditions. Electronic signs shall not exceed a maximum of 0.3 foot-candles during nighttime hours from sunset to sunrise. A foot-candle is a unit of measure of the intensity of light falling on a surface, equal to one lumen per square foot. The required distance shall be calculated using the following formula: (see section 4-15-06-02)

**PLN05: Section 4-15-07 Other Limitations; All off-premise signs shall meet the following requirements:**

1. All off-premise signs on the same side of a road or highway shall be separated by a minimum of two thousand (2,000) linear feet.

- The applicant has submitted documentation demonstrating they meet this requirement.
  - Staff is aware of the active application at 6750 York Street RCU2020-00015. In the event that RCU2020-00038 6612 York Street is approved, Staff will not support the application at 6750 York Street, due to the proximity of the parcels. I do see in your application that you acknowledge this issue. Maggie Barringer, Case Manager for RCU2020-00015 is under the impression that her case is still active and the applicant intends to pursue the CUP. If this is not the case, please formally submit to Ms. Barringer a request to close her case.
2. The minimum right-of-way and property line setback requirements shall be equal to the height of the billboard as measured from the leading edge of the sign face. Variations in the setback requirement may be granted with the issuance of a Conditional Use Permit.
    - The subject billboard is 32 feet high and would require a 32 foot setback from all property lines. The applicant is requesting a variation in the north (28'), south (30'), and west (28') setback.
    - Setback variations have been granted to the applicant in the past with the condition that the billboard be built to Category 3 Building Code requirements. Staff will apply the same condition of approval to this case for the approval of the variation in the setback.
  3. Setbacks from residentially zoned or used property: Not applicable.
  4. All off-premise signs may be illuminated.
  5. Off-premise signs which contain, include, or are illuminated by a changeable message including electronic, digital, LED, fiber optics, light bulbs, or other illumination devices are allowed and shall remain motionless for periods not less than four (4) seconds, with ten (10) seconds optimal. A Conditional Use Permit, Major Amendment to an existing Conditional Use Permit or Planned Unit Development shall be required prior to installing any electronic means to any off-premise sign.
  6. Where an off-premise sign has two (2) faces that are designed to be back-to back, the faces shall not be more than three and one half (3.5) feet from one another. Where an off-premise sign has two (2) faces arranged in a V-shape, the faces shall be: a maximum of 45 degrees at the interior angle, or a maximum of 15 feet apart at its widest point, whichever is less.
    - Applicant is requesting a V-shaped sign. The sign faces are proposed to be 15 feet apart at its widest point. Staff is requesting that the applicant confirm that 15 feet is less than the maximum 45 degree angle.
  7. Before any off-premise sign is erected, a building permit must be approved and issued by the Director of Community and Economic Development.

**PLN06: Criteria of Approval for a Conditional Use Permit; The Planning Commission, in making their recommendation, and the Board of County Commissioners, in approving a conditional use permit, shall find:**

1. The conditional use is permitted in the applicable zone district.
2. The conditional use is consistent with the purposes of these standards and regulations.
3. The conditional use will comply with the requirements of these standards and regulations, including but not limited to, all applicable performance standards.
4. The conditional use is compatible with the surrounding area, harmonious with the character of the neighborhood, not detrimental to the immediate area, not detrimental to the future development of the area, and not detrimental to the health, safety, or welfare of the inhabitants of the area and the County.
5. The conditional use permit has addressed all off-site impacts.
6. The site is suitable for the proposed conditional use including adequate usable space, adequate access, and absence of environmental constraints.
7. The site plan for the proposed conditional use will provide the most convenient and functional use of the lot including the parking scheme, traffic circulation, open space, fencing, screening, landscaping, signage, and lighting.
8. Sewer, water, storm water drainage, fire protection, police protection, and roads are available and adequate to serve the needs of the conditional use as designed and proposed.

**Commenting Division: Development Services, Engineering:**

**Name of Review:** Greg Labrie

**Email:** [GLabrie@adcogov.org](mailto:GLabrie@adcogov.org) / 720-523-6824

ENG1: Flood Insurance Rate Map – FIRM Panel # (08001C08001H), Federal Emergency Management Agency, March 5, 2007. According to the above reference, the project site is located within a special flood hazard delineated area; A floodplain use permit will be required.

ENG2: The developer is also required to obtain a building permit for the proposed structure.

ENG3: The project site is located in a NRCO district. An environmental assessment is required.

ENG4: Property is in MS4 area. Proposed improvements appear to be less than one acre in size. Applicant is responsible for installation and maintenance of Erosion and Sediment Control BMP's. Builder/developer is responsible for adhering to all the regulations of Adams County Ordinance 11 in regards to illicit discharge.

**Commenting Division: Development Services, Engineering (Right-of Way Review):**

**Name of Review:** David Dittmer

**Email:** [DDittmer@adcogov.org](mailto:DDittmer@adcogov.org) / 720-523-6811

No Comment



**From:** [Carla Gutierrez](#)  
**To:** [Layla Bajelan](#)  
**Subject:** Re: Request For Comments RCU2020-00038; 6612 York Street Billboard CUP  
**Date:** Monday, December 14, 2020 9:04:22 AM  
**Attachments:** [image001.png](#)

---

Please be cautious: This email was sent from outside Adams County

Good morning Layla,

At this time the Fire District has no questions or concerns.

Thank you!

*Carla Gutierrez*

Adams County Fire Rescue  
7980 Elmwood Lane  
Denver, CO 80221  
O: 303-539-6862

---

**From:** Layla Bajelan <LBajelan@adcogov.org>  
**Date:** Wednesday, November 25, 2020 at 9:18 AM  
**To:** Layla Bajelan <LBajelan@adcogov.org>  
**Subject:** Request For Comments RCU2020-00038; 6612 York Street Billboard CUP

## Request for Comments

Case Name: 6612 York St Billboard Conditional Use  
Permit  
Case Number: RCU2020-00038

November 25, 2020

The Adams County Planning Commission is requesting comments on the following application:  
**Conditional Use Permit for an electronic billboard. The subject property is zoned as C-5 and is visible from Highway 270.** This request is located at 6612 YORK ST. The Assessor's Parcel Number is 0182501303023.

Applicant Information:  
GARY YOUNG  
161 SATURN DRIVE UNIT 5A  
FORT COLLINS, CO 80525

**From:** [Jobe - CDOT, Jacquelyn](#)  
**To:** [Layla Bajelan](#); [Steven Loeffler - CDOT](#)  
**Subject:** Request for Comments RCU2020-00038; 6612 York Street Billboard CUP  
**Date:** Wednesday, December 9, 2020 9:45:30 AM

---

Please be cautious: This email was sent from outside Adams County

Layla,

The proposed electronic billboard request, which will advertise to and is visible from I-270, will require an Outdoor Advertising Permit from CDOT should it be approved by Adams County. We have no objection to this request.

Please let us know if you need any additional information from us.

Thank you.

--

Jacquelyn Jobe  
Technician III/Outdoor Advertising Coordinator  
Permits/Utilities/Traffic



P 303.512.4272 | F 303.757.9886

2829 W. Howard Place, 2nd Floor  
Denver, CO 80204

[jacquelyn.jobe@state.co.us](mailto:jacquelyn.jobe@state.co.us) | [www.coloradodot.info](http://www.coloradodot.info) | [www.cotrip.org](http://www.cotrip.org)

*The way to get started is to quit talking and begin doing.  
Walt Disney*



January 6, 2021

Layla Bajelan  
Adams County Community and Economic Development  
4430 South Adams County Parkway, Suite W2000A  
Brighton, CO 80601

RE: 6612 York Street Billboard, RCU2020-00038  
TCHD Case No. 6700

Dear Ms. Bajelan,

Thank you for the opportunity to review and comment on the conditional use permit application for a billboard located at 6612 York Street. Tri-County Health Department (TCHD) staff has reviewed the application for compliance with applicable environmental and public health regulations and principles of healthy community design. After reviewing the application, TCHD has no comments.

Please feel free to contact me at 720-200-1575 or [kboyer@tchd.org](mailto:kboyer@tchd.org) if you have any questions about TCHD's comments.

Sincerely,

A handwritten signature in black ink, appearing to read "K Boyer", with a horizontal line extending to the right.

Kathy Boyer, REHS  
Land Use and Built Environment Specialist III

cc: Sheila Lynch, Monte Deatrich, TCHD



Right of Way & Permits  
1123 West 3<sup>rd</sup> Avenue  
Denver, Colorado 80223  
Telephone: 303.571.3306  
Facsimile: 303.571.3284  
donna.l.george@xcelenergy.com

December 18, 2020

Adams County Community and Economic Development Department  
4430 South Adams County Parkway, 3<sup>rd</sup> Floor, Suite W3000  
Brighton, CO 80601

Attn: Layla Bajelan

**Re: 6612 York Street Billboard Conditional Use Permit, Case # RCU2020-00038**

Public Service Company of Colorado's (PSCo) Right of Way & Permits Referral Desk has reviewed the CUP documentation for **6612 York Street** and has **no apparent conflict**.

Please be aware PSCo owns and operates existing underground electric distribution facilities along Columbine Street. The property owner/developer/contractor must complete the application process for any new electric service, or modification to existing facilities via [xcelenergy.com/InstallAndConnect](http://xcelenergy.com/InstallAndConnect). It is then the responsibility of the developer to contact the Designer assigned to the project for approval of design details. Additional easements may need to be acquired by separate document for new facilities.

As a safety precaution, PSCo would like to remind the developer to call the Utility Notification Center by dialing 811 for utility locates prior to construction.

Donna George  
Right of Way and Permits  
Public Service Company of Colorado dba Xcel Energy  
Office: 303-571-3306 – Email: donna.l.george@xcelenergy.com

Community & Economic  
Development Department  
Development Services Division  
www.adcogov.org



4430 South Adams County Parkway  
1st Floor, Suite W2000B  
Brighton, CO 80601-8218  
PHONE 720.523.6800  
FAX 720.523.6967

## Request for Comments

Case Name: 6612 York St Billboard Conditional Use Permit  
Case Number: RCU2020-00038

November 25, 2020

The Adams County Planning Commission is requesting comments on the following application: **Conditional Use Permit for an electronic billboard. The subject property is zoned as C-5 and is visible from Highway 270.** This request is located at 6612 YORK ST. The Assessor's Parcel Number is 0182501303023.

Applicant Information: StreetMediaGroup, LLC  
GARY YOUNG  
161 SATURN DRIVE UNIT 5A  
FORT COLLINS, CO 80525

Please forward any written comments on this application to the Community and Economic Development Department at 4430 South Adams County Parkway, Suite W2000A Brighton, CO 80601-8216 or call (720) 523-6800 by **12/17/2020** in order that your comments may be taken into consideration in the review of this case. If you would like your comments included verbatim please send your response by way of e-mail to [LBajelan@adcogov.org](mailto:LBajelan@adcogov.org).

Once comments have been received and the staff report written, the staff report and notice of public hearing dates may be forwarded to you upon request. The full text of the proposed request and additional colored maps can be obtained by contacting this office or by accessing the Adams County web site at [www.adcogov.org/planning/currentcases](http://www.adcogov.org/planning/currentcases).

Thank you for your review of this case.

Layla Bajelan  
Planner II

BOARD OF COUNTY COMMISSIONERS

Eva J. Henry  
DISTRICT 1

Charles "Chaz" Tedesco  
DISTRICT 2

Emma Pinter  
DISTRICT 3

Steve O'Doriso  
DISTRICT 4

Mary Hodge  
DISTRICT 5



## Public Hearing Notification

Case Name:	StreetMedia 6612 York Street Billboard CUP
Case Number:	RCU2020-00038
Planning Commission Hearing Date:	01/28/2021 at 6:00 p.m.
Board of County Commissioners Hearing Date:	02/23/2021 at 9:30 a.m.

January 06, 2021

A public hearing has been set by the Adams County Planning Commission and the Board of County Commissioners to consider the following request: Conditional Use Permit for an electronic billboard. The subject property is zoned as C-5 and is visible from Highway 270. The Assessor's Parcel Number(s) 0182501303023.

Applicant Information:  
Gary Young  
StreetMedia Group, LLC.  
161 Saturn Drive Unit 5A  
Fort Collins, CO 80525

Owner Information:  
Euro LLC.  
18577 E. Hamilton Dr.  
Aurora, Colorado 80013

The Planning Commission meeting will be held virtually using the Zoom video conferencing software and members of the public will be able to submit comments prior to the start of the public hearing that will then be entered into the record. For instructions on how to access the public hearing via telephone or internet, or to submit comment, please visit <http://www.adcogov.org/planning-commission> for up to date information.

The Board of County Commissioners meeting is broadcast live on the Adams County YouTube channel and members of the public will be able to submit comments prior to the start of the public hearing that will then be entered into the record. The eComment period opens when the agenda is published and closes at 4:30 p.m. the Monday prior to the noticed meeting. For instructions on how to access the public hearing and submit comments, please visit <http://www.adcogov.org/bocc> for up to date information.

These will be public hearings and any interested parties may attend and be heard. The Applicant and Representative's presence at these hearings is requested. The full text of the proposed request and additional colored maps can be obtained by accessing the Adams County Community and Economic Development Department website at [www.adcogov.org/planning/currentcases](http://www.adcogov.org/planning/currentcases).

Thank you for your review of this case.

A handwritten signature in black ink that reads "Layla Bajelan". The signature is written in a cursive, flowing style.

Layla Bajelan, Long Range Planner II  
[LBajelan@adcogov.org](mailto:LBajelan@adcogov.org)  
720.523.6863

## **PUBLICATION REQUEST**

**Case Name:** StreetMedia 6612 York Street Billboard CUP

**Case Number:** RCU2020-00038

**Planning Commission Hearing Date:** 01/28/2021 at 6:00 p.m.

**Board of County Commissioners Hearing Date:** 02/23/2021 at 9:30 a.m.

**Case Manager:** Layla Bajelan, Long-Range Planner II, [LBajelan@adcogov.org](mailto:LBajelan@adcogov.org) 720.523.6863

**Request:** Conditional Use Permit for an electronic billboard. The subject property is zoned as C-5 and is visible from Highway 270.

**Parcel Number (s):** 0182501303023

**Address of the Request:** 6612 York Street

**Applicant:** Gary Young StreetMedia Group, LLC. 161 Saturn Drive Unit 5A Fort Collins, CO 80525

**Owner:** Euro JG LLC 18577 E. Hamilton Dr. Aurora, Colorado 80013

**Legal Description:** Lot 2, Chaplinskiy Subdivision County of Adams, State of Colorado

### **Virtual Meeting and Public Comment Information:**

These meetings will be held virtually. Please visit <http://www.adcogov.org/planning-commission> and <http://www.adcogov.org/bocc> for up to date information on accessing the public hearings and submitting comment prior to the hearings. The full text of the proposed request and additional colored maps can be obtained by accessing the Adams County Community and Economic Development Department website at [www.adcogov.org/planning/currentcases](http://www.adcogov.org/planning/currentcases).





Referral Listing  
Case Number RCU2020-00038  
6612 York St Billboard Conditional Use Permit

Agency

Contact Information

ADAMS 12 FIVE STAR SCHOOLS

MATT SCHAEFER - PLANNING MANAGER  
1500 E. 128TH AVENUE  
THORNTON CO 80241  
720-972-4289  
matt.schaefer@adams12.org

Adams County Attorney's Office

Christine Fitch  
4430 S Adams County Pkwy  
Brighton CO 80601  
720-523-6352  
CFitch@adcogov.org

Adams County CEDD Development Services Engineer

Devt. Services Engineering  
4430 S. Adams County Pkwy.  
Brighton CO 80601  
720-523-6800

Adams County CEDD Environmental Services Division

Katie Keefe  
4430 S. Adams County Pkwy.  
Brighton CO 80601  
720-523-6986  
kkeefe@adcogov.org

Adams County CEDD Right-of-Way

Mark Alessi  
4430 S. Adams County Pkwy.  
Brighton CO 80601  
720-523-6837  
malessi@adcogov.org

Adams County Community Safety & Wellbeing, Neighborhood Services

Gail Moon  
4430 S. Adams County Pkwy.  
Brighton CO 80601  
720-523-6856  
gmoon@adcogov.org

Adams County Development Services - Building

Justin Blair  
4430 S Adams County Pkwy  
Brighton CO 80601  
720-523-6825  
JBlair@adcogov.org

Adams County Fire Protection District

Carla Gutierrez  
7980 Elmwood Ln.  
Denver CO 80221  
303-539-6862  
cgutierrez@acfpd.org

Agency

Contact Information

---

Adams County Parks and Open Space Department

Marc Pedrucci  
303-637-8014  
mpedrucci@adcogov.org

Adams County Parks and Open Space Department

Aaron Clark  
(303) 637-8005  
aclark@adcogov.org

ADAMS COUNTY SCHOOL DISTRICT 14

Leo Rodriguez  
5291 E. 60th Avenue  
COMMERCE CITY CO 80022  
303.853.3217  
lrodriguez@adams14.org

Adams County Sheriff's Office

Rick Reigenborn  
(303) 654-1850  
rreigenborn@adcogov.org

Adams County Sheriff's Office

--  
303-655-3283  
CommunityConnections@adcogov.org

BERKELEY WATER

Paul Peloquin  
4455 W 58TH AVE UNIT A  
Arvada CO 80002  
(303) 477-1914  
paul.peloquin@denverwater.org

BERKELEY WATER & SAN DISTRICT

SHARON WHITEHAIR  
4455 W 58TH AVE UNIT A  
ARVADA CO 80002  
(303) 477-1914  
berkeleywater@gmail.com

CDPHE

Sean Hackett  
4300 S Cherry Creek Dr  
Denver CO 80246  
303.692.3662 303.691.7702  
cdphe\_localreferral@state.co.us

CDPHE - WATER QUALITY PROTECTION SECT

Patrick Pfaltzgraff  
4300 CHERRY CREEK DRIVE SOUTH  
WQCD-B2  
DENVER CO 80246-1530  
303-692-3509  
cdphe\_localreferral@state.co.us

CDPHE SOLID WASTE UNIT

Andy Todd  
4300 CHERRY CREEK DR SOUTH  
HMWMD-CP-B2  
DENVER CO 80246-1530  
303.691.4049  
cdphe\_localreferral@state.co.us

Century Link, Inc

Brandyn Wiedreich  
5325 Zuni St, Rm 728  
Denver CO 80221  
720-578-3724 720-245-0029

Agency

Contact Information

---

CITY OF THORNTON

JASON O'SHEA  
9500 CIVIC CENTER DR  
THORNTON CO 80229  
0

CITY OF THORNTON

Lori Hight  
9500 CIVIC CENTER DRIVE  
THORNTON CO 80229  
303-538-7670  
developmentsubmittals@cityofthornton.net.

CITY OF THORNTON

JIM KAISER  
12450 N WASHINGTON  
THORNTON CO 80241  
720-977-6266

COLORADO DEPT OF TRANSPORTATION

Steve Loeffler  
2000 S. Holly St.  
Region 1  
Denver CO 80222  
303-757-9891  
steven.loeffler@state.co.us

COLORADO DIVISION OF WILDLIFE

Serena Rocksund  
6060 BROADWAY  
DENVER CO 80216  
3039471798  
serena.rocksund@state.co.us

COLORADO DIVISION OF WILDLIFE

Matt Martinez  
6060 BROADWAY  
DENVER CO 80216-1000  
303-291-7526  
matt.martinez@state.co.us

COMCAST

JOE LOWE  
8490 N UMATILLA ST  
FEDERAL HEIGHTS CO 80260  
303-603-5039

Commerce City Planning Division

Domenic Martinelli  
7887 East 60th Avenue  
COMMERCE CITY CO 80022  
303-289-3693  
dmartinelli@c3gov.com

Crestview Water & Sanitation

Patrick Stock  
7145 Mariposa St  
PO Box 21299  
Denver CO 80221-0299  
303-430-1660 303-434-0607  
PatrickStock@crestviewwater.net

INDUSTRIAL PARK

KEARBY COTTER  
6625 E. 49TH AVE.  
COMMERCE CITY CO 80022  
303-288-1511

Agency

Contact Information

---

MAPLETON SCHOOL DISTRICT #1

CHARLOTTE CIANCIO  
591 E. 80TH AVE  
DENVER CO 80229  
303-853-1015  
charlotte@mapleton.us

METRO WASTEWATER RECLAMATION

CRAIG SIMMONDS  
6450 YORK ST.  
DENVER CO 80229  
303-286-3338  
CSIMMONDS@MWRD.DST.CO.US

Neighborhood Improvement Committee

LARRY QUINTANA  
7780 MAGNOLIA ST  
COMMERCE CITY CO 80022  
3039557758

North Lincoln Water and Sanitation District

JORGE HINOJOS  
1560 Broadway  
Suite 1400  
Denver CO 80202  
303-861-0061  
jorge.hinojos@tetrattech.com

North Lincoln Water and Sanitation District

- -  
-  
nlwsdistrict1@gmail.com

North Pecos Water & Sanitation District

Russell Traska  
6900 Pecos St  
Denver CO 80221  
303-429-5770  
manager@northpecoswater.org

North Washington Street Water & San Dist

Mike DeMattee  
3172 E 78th Ave  
Denver CO 80229  
303-288-6664  
mdemattee@nwsd.com

NS - Code Compliance

Kerry Gress  
kgress@adcogov.org  
720.523.6832  
kgress@adcogov.org

NS - Code Compliance

Gail Moon  
gmoon@adcogov.org  
720.523.6833  
gmoon@adcogov.org

NS - Code Compliance

Brooke Pettry  
4430 S. Adams County Pkwy  
Brighton CO 80601  
720.523.6206  
bpettry@adcogov.org

NS - Code Compliance

Joaquin Flores  
720.523.6207  
jflores@adcogov.org

Agency

Contact Information

---

Pecos Park Logistics Park Metro District

M Mitchell  
4221 Brighton Blvd  
Denver CO 802163719  
303-298-1111  
mmitchell@westfield-co.com

PERL MACK NEIGHBORHOOD GROUP

DAN MICEK - PRESIDENT  
7294 NAVAJO ST.  
DENVER CO 80221  
303-428-8557  
DANMICEK54@COMCAST.NET

REGIONAL TRANSPORTATION DIST.

Engineering RTD  
1560 BROADWAY SUITE 700  
DENVER CO 80202  
303-299-2439  
engineering@rtd-denver.com

SOUTH ADAMS CO. FIRE DISTRICT

Randall Weigum  
6050 Syracuse Street  
COMMERCE CITY CO 80022  
720-573-9790 FAX: 303-288-5977  
rweigum@sacfd.org

SOUTH ADAMS CO. FIRE DISTRICT

- Fire Prevention Division  
6050 Syracuse Street  
Commerce City CO 80022  
303-288-0835  
planreview@sacfd.org

South Adams County Water & San Dist

Abel Moreno  
10200 E 102nd Ave  
Henderson CO 80022  
720-206-0590  
amoreno@sacwds.org

SOUTH ADAMS COUNTY WATER AND SANITATION DISTRICT

NELSON JEFF  
  
10200 E. 102ND AVENUE  
HENDERSON CO 80640  
720.206.0593 720.530.8396  
JNELSON@SACWSD.ORG

THORNTON FIRE DEPARTMENT

Chad Mccollum  
9500 Civic Center Drive  
THORNTON CO 80229-4326  
303-538-7602  
firedept@cityofthornton.net

UNION PACIFIC RAILROAD

Anna Dancer  
1400 DOUGLAS ST STOP 1690  
OMAHA NE 68179  
402-544-2255  
aldancer@up.com

WELBY CITIZEN GROUP

NORMA FRANK  
7401 RACE STREET  
DENVER CO 80229  
(303) 288-3152

Agency

Contact Information

---

WESTMINSTER SCHOOL DISTRICT #50

Jackie Peterson  
7002 Raleigh Street  
WESTMINSTER CO 80030  
720-542-5100  
jpeterson@adams50.org

Xcel Energy

Donna George  
1123 W 3rd Ave  
DENVER CO 80223  
303-571-3306  
Donna.L.George@xcelenergy.com

Xcel Energy

Donna George  
1123 W 3rd Ave  
DENVER CO 80223  
303-571-3306  
Donna.L.George@xcelenergy.com

A T AND W INC  
5370 MAGNOLIA ST  
COMMERCE CITY CO 80022-4308

PUBLIC SERVICE CO OF COLORADO  
C/O PROPERTY AND LOCAL TAXES  
PO BOX 1979  
DENVER CO 80201-1979

ADAMS COUNTY  
4430 SOUTH ADAMS COUNTY PKWY  
BRIGHTON CO 80601-8204

WELAND TODD P  
6750 YORK ST  
DENVER CO 80229-7307

CHRISTENSON JUSTIN D AKA SHIRLEY JUSTIN  
D UND 3/4 INT/KLEIN BEN UND 1/4TH INT  
3775 CHIMAYO ROAD  
LITTLETON CO 80123

CHAPLINSKIY ANATOLIY AND  
CHAPLINSKAYA MARINA  
OR CURRENT RESIDENT  
6610 YORK STREET  
DENVER CO 80221

CITY AND COUNTY OF DENVER ACTING BY AND  
THROUGH ITS BOARD OF WATER COMMISSIONERS  
1600 W 12TH AVE  
DENVER CO 80204-3412

KUHNS LARRY R AND  
KUHN MARIANNE C  
OR CURRENT RESIDENT  
6620 YORK ST  
DENVER CO 80229-7322

CITY OF COMMERCE CITY  
7887 E 60TH AVE  
COMMERCE CITY CO 80022-4199

METROPOLITAN DENVER SEWAGE  
DISPOSAL DIST NO.1  
OR CURRENT RESIDENT  
6450 YORK ST  
DENVER CO 80229-7407

EURO JG LLC  
18577 E HAMILTON DR  
AURORA CO 80013-5722

CURRENT RESIDENT  
6656 YORK ST  
DENVER CO 80229-7322

LAMMERS HAROLD R JR  
14831 CHAMBERS RD  
BRIGHTON CO 80601-6739

CURRENT RESIDENT  
6686 YORK ST  
DENVER CO 80229-7322

METRO WASTEWATER  
RECLAMATION DISTRICT  
6450 YORK ST  
DENVER CO 80229-7407

CURRENT RESIDENT  
2751 E 69TH WAY  
DENVER CO 80229-7512

METRO WASTEWATER RECLAMATION  
DISTRICT  
6450 YORK ST  
DENVER CO 80229-7407

METRO WASTEWATER RECLAMATION DISTRICT  
6450 YORK ST  
DENVER CO 80229-7407

## CERTIFICATE OF POSTING



I, Layla Bajelan, do hereby certify that I had the property posted at

6612 York Street

on January 13, 2021

In accordance with the requirements of the Adams County Zoning Regulations

*Layla Bajelan*

Layla Bajelan



# StreetMedia 6612 York Street Billboard CUP

RCU2020-00038

6612 York Street

February 23, 2021

Board of County Commissioners Public Hearing  
Community and Economic Development Department

Case Manager: Layla Bajelan



# Request

Conditional Use Permit to allow an off-premise electronic sign (billboard) in Commercial-5 (C-5).

# Aerial View



Interstate-270

E. 66th Street

York Street

Site

E 64th Ave

E 64th Ave

270

E 68th Pl

E 68th Ave

E 66th Ave

York St

Aerial View



Site

Approximate  
Location for the  
Billboard

Interstate-270

270

# Current Zoning

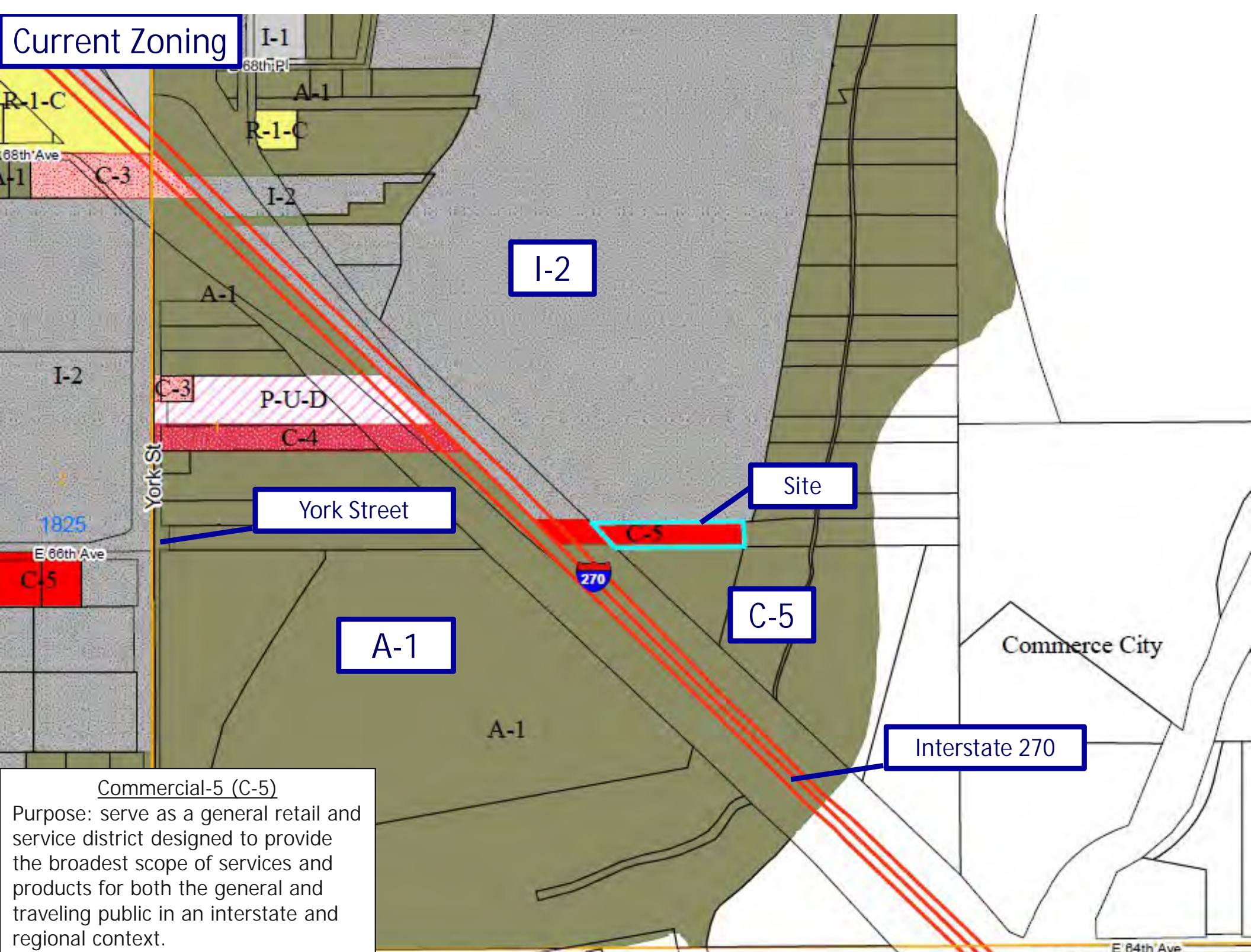

York Street

Site

A-1

C-5

Interstate 270

Commercial-5 (C-5)  
Purpose: serve as a general retail and service district designed to provide the broadest scope of services and products for both the general and traveling public in an interstate and regional context.

# Future Land Use Map

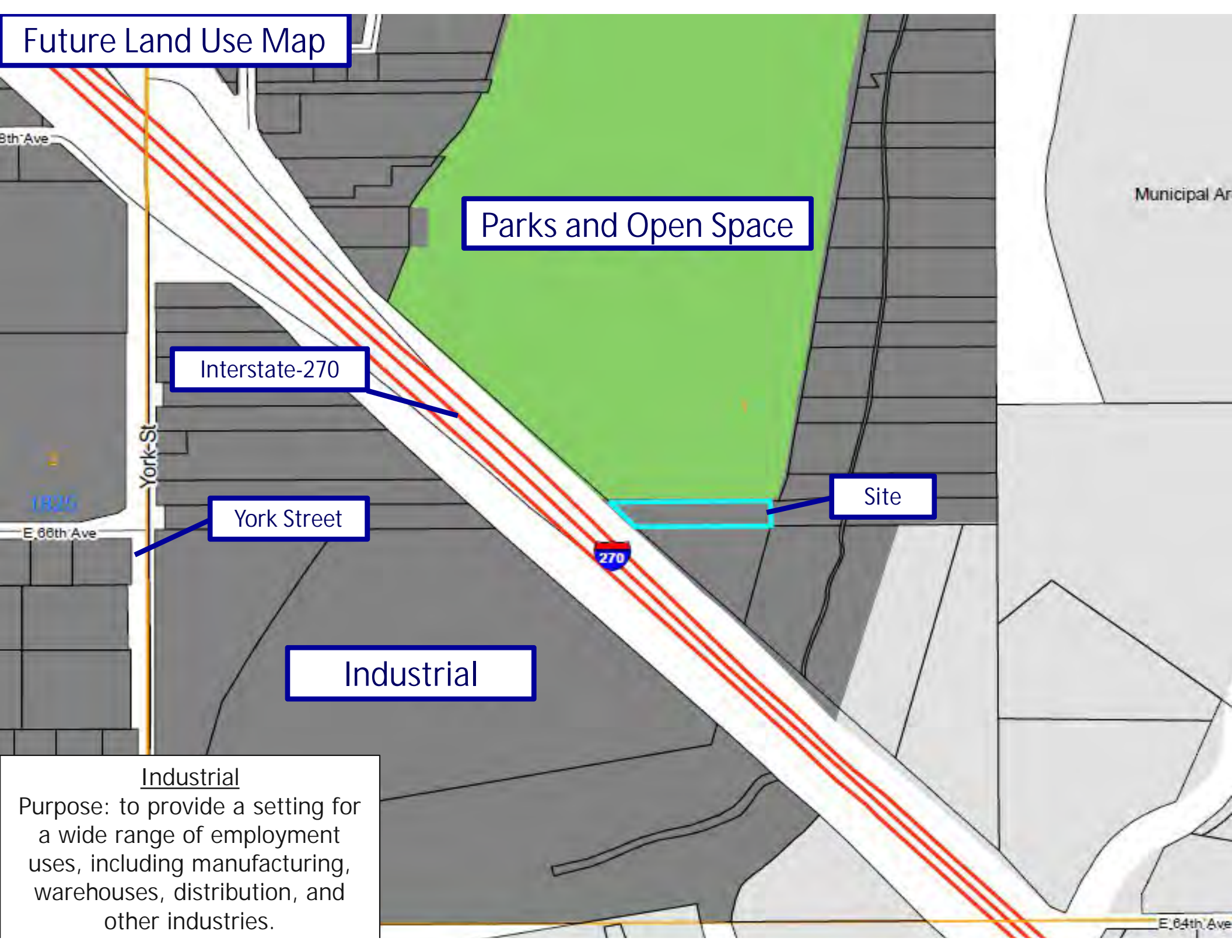

Parks and Open Space

Interstate-270

York Street

Industrial

Site

## Industrial

Purpose: to provide a setting for a wide range of employment uses, including manufacturing, warehouses, distribution, and other industries.

Municipal Ar

E 64th Ave

# Criteria for Conditional Use

Section 2-02-09-06

1. Permitted in zone district
2. Consistent with regulations
3. Complies with performance standards
4. Harmonious & compatible
5. Addressed all off-site impacts
6. Site suitable for use
7. Site plan adequate for use
8. Adequate services

# Performance Standards

- Maximum Height: 40 feet, 32 ft proposed
- Maximum Size: 300 sq. ft. , 300 sq. ft proposed
- Only one two-faced off-premise sign
- Setback equal to the height
  - Variations in setback may be permitted
- Minimum of 2,000 ft. on the same side of the road
- Sign faces
  - V-Shaped: Maximum of 45 degrees or 15 feet apart, whichever is less.
- Remain motionless for a min. of 4 seconds, 10 is optimal

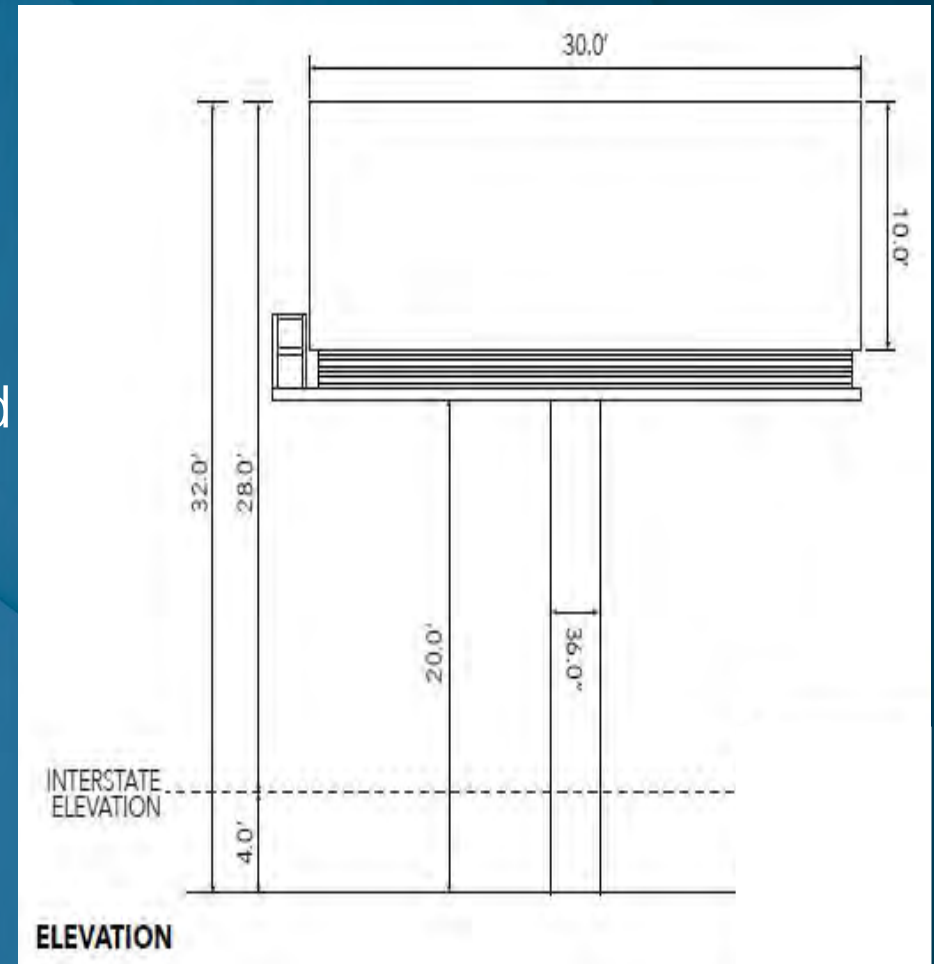



# Applicant Vicinity Map



No existing billboards  
within 2,000 ft. in  
either direction

PROPOSED BILLBOARD

**SITE PLAN**  
6612 YORK ST

**StreetMediaGroup**  
161 Saturn Dr., Ste 5 | Fort Collins, CO 80525

# Applicant Site Plan

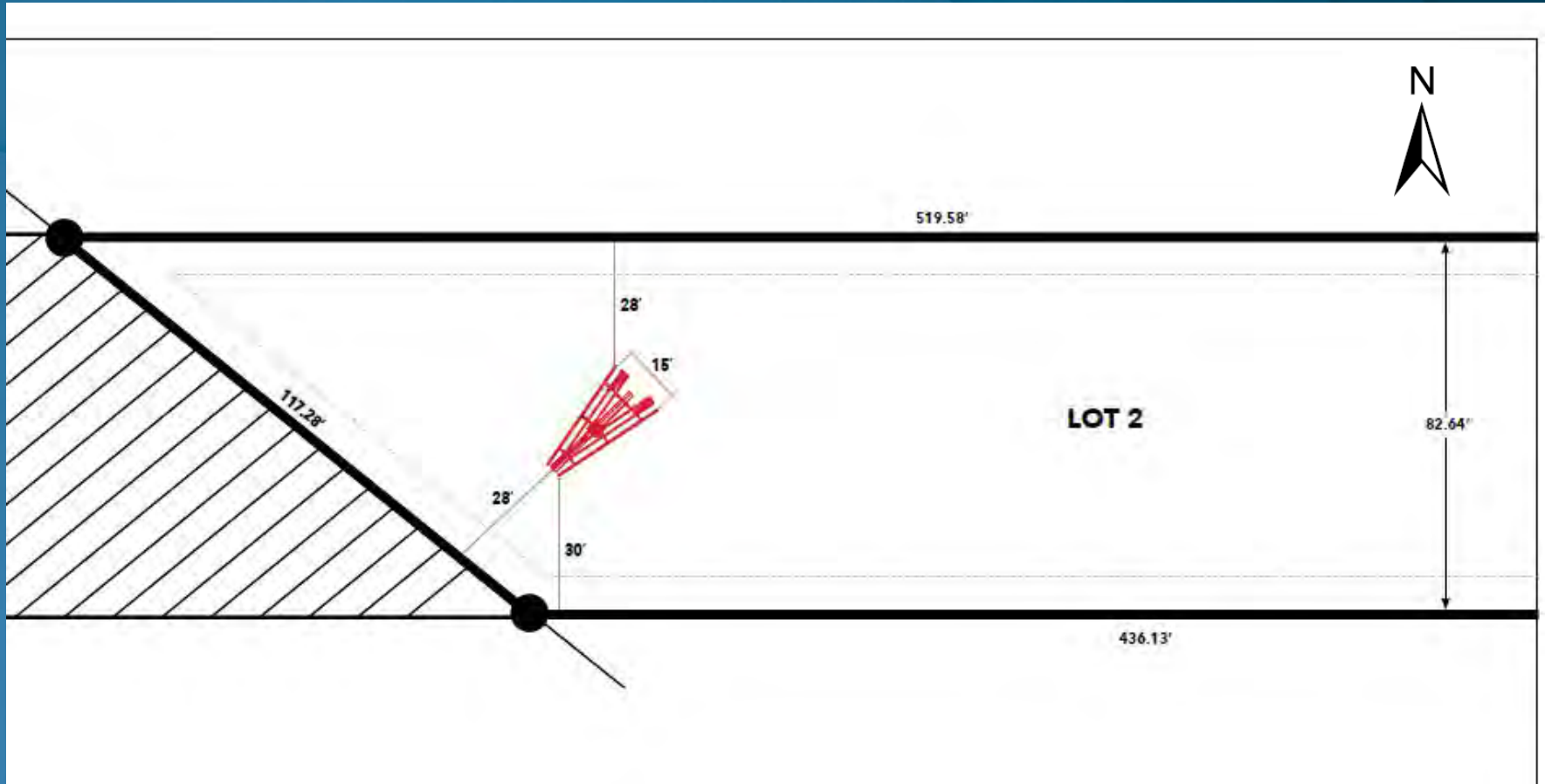

# Variation in Setback

Applicant is requesting a variation in setback.

- 32 feet required
- Requested setbacks:
  - Northern and Western Setbacks: 28 feet
  - Southern Setback: 30 feet

## Recommended Condition of Approval:

- The Applicant shall build the billboard to a Category Three Building Code standard, which will be reviewed at the time of Building Permit application.







# Photosimulation



**PHOTOSIMULATION**  
6612 YORK ST

**StreetMediaGroup**  
161 Saturn Dr., Ste 5 | Fort Collins, CO 80525

# Referral Comments

Notifications Sent*	# Comments Received
18	0

\*Property owners and occupants within 1,000 ft.

Referral Agencies:

Responding without concern: CDOT, TCHD, XCEL

No major concerns were identified



# PC Update

- PC Hearing- January 28, 2021
- Planning Commission voted to recommend approval (6-1) of the subject request WITH the applicant's request for a variation in the setback, with 8 Findings-of-Fact, 6 Conditions, and 3 Notes to the applicant.
- No major concerns identified by PC

# Staff Recommendation

(RCU2020-00038 StreetMedia 6612 York Street Billboard CUP)

Staff recommends APPROVAL of the subject request (RCU2020-00038) WITH the applicant's request for a variation in the setback, with 8 Findings-of-Fact, 6 Conditions, and 3 Notes to the applicant.

# Recommended Findings-of-Fact

1. The conditional use is permitted in the applicable zone district.
2. The conditional use is consistent with the purposes of these standards and regulations.
3. The conditional use will comply with the requirements of these standards and regulations, including but not limited to, all applicable performance standards.
4. The conditional use is compatible with the surrounding area, harmonious with the character of the neighborhood, not detrimental to the immediate area, not detrimental to the future development of the area, and not detrimental to the health, safety, or welfare of the inhabitants of the area and the County.
5. The conditional use permit has addressed all off-site impacts.
6. The site is suitable for the proposed conditional use including adequate usable space, adequate access, and absence of environmental constraints.
7. The site plan for the proposed conditional use will provide the most convenient and functional use of the lot including the parking scheme, traffic circulation, open space, fencing, screening, landscaping, signage, and lighting.
8. Sewer, water, storm water drainage, fire protection, police protection, and roads are available and adequate to serve the needs of the conditional use as designed and proposed.

# Recommended Conditions

1. The applicant must show compliance with all the requirements of the Colorado Outdoor Advertising Act, C.R.S. 43-1-401 et. Seq. and the Colorado rules and regulations promulgated thereunder by the Colorado Department of Transportation.
2. The applicant shall obtain an Outdoor Advertising Permit from the Colorado Department of Transportation.
3. The applicant shall obtain a building permit from Adams County for the billboard, including all required building permit inspections.
4. Each message displayed on the billboard shall remain static for a minimum of four (4) seconds and must transition immediately to the next message displayed.
5. The approval of the off-premise sign shall expire February 23, 2031 unless renewed.
6. The Applicant shall build the billboard to a Category Three Building Code standard, which will be reviewed at the time of Building Permit application.

# Recommended Note to the Applicant

1. All applicable building, zoning, health, fire, and engineering requirements and codes shall be adhered to with this request. The applicant may submit an alternative design that can be approved through a Minor Amendment to this Conditional Use Permit by staff, as long as the design complies with the Adams County Development Standards and Regulations at the time of building permit application.
2. The conditional use permit shall expire on February 23, 2022 if sign permits are not obtained from Adams County.
3. Any sign or attractive device which includes animated images or graphics, scrolling messages, video, moving images similar to television images, emits audible sounds, employs stereopticon, or includes motion picture projection is prohibited.

# Light Analysis



# V-Shaped Billboard

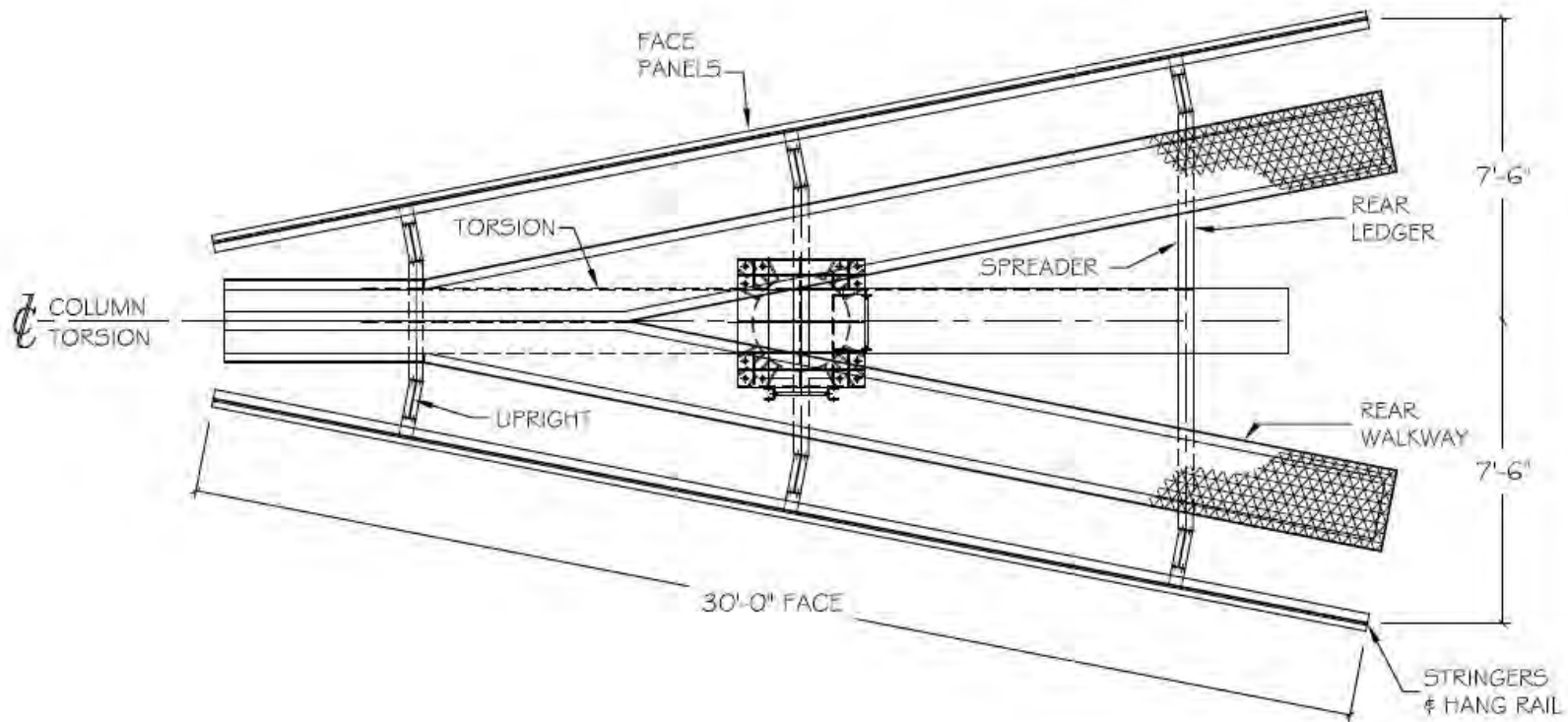

**SITE PLAN**  
6612 YORK ST

**StreetMediaGroup**  
141 Saturn Dr. Ste 5 | Fort Collins, CO 80525

# Southwest Area Framework Plan

- Policy 14.7 to Enhance the area's role as an important County Gateway. Strategies in completing the goals include:
  - 1) 14.7.a. Entryway Image
  - 2) 14.7.b. Screening and Buffering
  - 3) 14.7.c Signs- Review and update the sign regulation provisions, including control of off-premise signs, applicable to private lands visible from I-70, I-25, and I-76 and key highway exits into the County.





COMMUNITY AND ECONOMIC DEVELOPMENT  
DEPARTMENT

CASE NO.: RCU2020-00014

CASE NAME: StreetMedia 7154 Washington Billboard CUP

**TABLE OF CONTENTS**

**EXHIBIT 1 – BoCC Staff Report**

**EXHIBIT 2 – Maps**

- 2.1 Aerial Map
- 2.2 Zoning Map
- 2.3 Future Land Use Map
- 2.4 Simple Map

**EXHIBIT 3 – Applicant Information**

- 3.1 Applicant Written Explanation
- 3.2 Applicant Site Plan
- 3.3 Applicant Vicinity Map
- 3.4 Applicant Photos
- 3.5 Applicant Photometric Plan

**EXHIBIT 4 – Referral Comments**

- 4.1 Referral Comment (Adams County 1<sup>st</sup> Review)
- 4.2 Referral Comment (Adams County 2<sup>nd</sup> Review)
- 4.3 Referral Comment (Colorado Department of Transportation)
- 4.4 Referral Comment (Regional Transportation District)
- 4.5 Referral Comment (Tri-County Health Department)
- 4.6 Referral Comment (Xcel Energy)

**EXHIBIT 5 – Associated Case Materials**

- 5.1 Request for Comments
- 5.2 Public Hearing Notice
- 5.3 Newspaper Publication
- 5.4 Referral Agency Labels
- 5.5 Property Owner and Resident Labels
- 5.6 Certificate of Posting



**COMMUNITY AND ECONOMIC DEVELOPMENT  
DEPARTMENT  
STAFF REPORT**

**Board of County Commissioners**

**February 23, 2021**

<b>CASE No.: RCU2020-00014 CASE NAME: StreetMedia 7154 Washington Billboard CUP</b>	
Owner's Name:	Center Land Properties, Inc.
Applicant's Name:	StreetMedia Group, LLC
Applicant's Address:	161 Saturn Drive, Unit 5A, Fort Collins, CO 80525
Location of Request:	7154 Washington Street (Parcel # 0182502202021)
Nature of Request:	Conditional Use Permit for an off-premise electronic advertising device (billboard) in the C-5 zone district visible from I-270
Zone District:	Commercial-5 (C-5)
Future Land Use:	Mixed Use Employment
Site Size:	4.32 acres (188,179 sq. ft.)
Proposed Use:	Business Park, Office, and Warehousing with an electronic billboard located on site
Existing Use:	Business Park Office, and Warehousing
Hearing Date(s):	<b>PC: January 28, 2021/ 6:00 pm</b>
	<b>BoCC: February 23, 2021/ 9:30 am</b>
Report Date:	January 21, 2021
Case Manager:	Holden Pederson
Staff Recommendation:	APPROVAL with 8 Findings-of-Fact, 6 Conditions, and 3 Notes

**SUMMARY OF APPLICATION**

**Background:**

The subject property is located in the North Side Gardens Subdivision recorded in 1926.

In 2018, the property was approved for a rezone (RCU2017-00050) from Commercial-4 (C-4) to Commercial-5 (C-5).

In 2019, the property was approved for a conditional use permit (RCU2018-00028) in order to allow a 40' tall off-premise electronic advertising device (billboard) on the site, with an expiration date of January 15, 2029.

The applicant, StreetMedia Group, is requesting a new Conditional Use Permit in order to allow a 40' tall off-premise electronic advertising device (billboard) in the C-5 zone district.

Although a conditional use permit for a 40' billboard was previously approved for the site in 2019, this new conditional use permit application is required according to Section 2-02-09-09 of the County's Development Standards and Regulations (DSR). This section states that if at the expiration of one year, a building permit has not been issued for the use for which the conditional use permit was approved or the approved conditional use has not been established, the conditional use permit shall expire and the use of the property shall revert to its formerly allowed used without action by the Board of County Commissioners.

**Site Characteristics:**

The subject property is located in the C-5 zone district and is approximately 4.32 acres. The lot has frontage and direct access to Washington Street to the west, Interstate-270 to the north, and Interstate-25 to the west. The existing use at the site is called the Clear Creek Valley Business Park. The property is developed with two multi-tenant commercial buildings, associated parking, and landscaping. It is primarily utilized for business park uses such as warehousing and offices.

The site is located adjacent to the nearby interstate and in general has excellent visibility from I-270 to the north. The location of the subject billboard would be in the northeast corner of the site within a paved area. There is an existing building along the north property line that prevents the billboard's placement directly next to the interstate. Instead, the billboard will need to be placed on the south end of the building with the billboard face stretching north above the structure so that it is visible from the nearby interstate.

The billboard pole is proposed to be setback 107' from the north property line and 106' from the east property line, while the billboard face is proposed to be setback 45' from the north property line and 94' from the east property line. The site's parking and vehicle use area is located in the middle of the property between the two structures, and the proposed billboard will not interfere with vehicle circulation throughout the site due to its close proximity to the north building and the interstate.

**Development Standards and Regulations:**

The property is zoned C-5. Per Section 3-25-01 of the County's Development Standards and Regulations, the purpose of the Commercial-5 District is to serve as a general retail and service district designed to provide the broadest scope of services and products for both the general and traveling public in an interstate and regional context. In certain situations, it may be appropriate through a conditional use permit to allow a mix of uses in this zone district – allowing both residential and commercial uses within one building.

Section 4-16 of the County's Development Standards and Regulations outlines the required design and performance standards for billboards, which include standards for electronic signs. These standards ensure outdoor advertising devices are properly located to minimize visual and physical impacts to surrounding properties. Required design standards include the following: maximum height, maximum sign area, number of billboards allowed per lot, minimum setbacks from property lines, and minimum spacing from other off-premise signs.

Section 4-16-07 of the County's Development Standards and Regulations outlines other limitations for off-premise signs. The minimum right-of-way and property line setback requirements must be equal to the height of the billboard, as measured from the leading edge of the base of the sign face. The applicant is requesting a 45' setback from the north property line and a 94' setback from the east property line from the leading edge of the sign face for a 40' tall sign, which meets the minimum setback requirement.

The applicant has submitted a site plan and elevation drawings with the subject request. The proposed sign has two advertising faces, with each being 300 square feet per sign face. The proposed height and size of the billboard conforms to the County's required maximum height of 40' and maximum sign area of 300 square feet for each single sign face. When a sign has two faces arranged in a V-shape, the faces may be a maximum of 45 degrees at the interior angle or a maximum of 15' apart at its widest point, whichever is less. The proposed billboard also conforms to the County's required maximum spacing between sign faces.

Per Section 4-16-03 of the County's DSR, only one off-premise sign is permitted per lot. In addition, per Section 4-16-07, all off-premise signs located on the same side of a road or highway must be separated by a minimum of 2,000 linear feet. The proposed billboard will be the only billboard permitted on the property and the applicant has provided documentation demonstrating that no other billboards are located within 2,000 linear feet of the subject site. According to the applicant, no existing billboards are located within 3,000 linear feet to the east or west of the proposed billboard. A recent site visit and drive-by has confirmed compliance with the requirement.

Per Section 4-16-06-02 of the County's DSR, an electronic sign is permitted as part of a billboard. Performance standards for electronic signs include duration of message, transition of message, prohibited electronic devices, and maximum brightness. According to the DSR, each message displayed must remain static for a minimum of four seconds and must transition immediately to the next message displayed. In accordance with Section 4-16-06-02 of the County's DSR, electronic devices must not display animated images or graphics, scrolling messages, videos, or emit audible sounds. In addition, each sign must be equipped with light monitors and controls that automatically adjust to environmental conditions. According to the applicant, the proposed billboard will conform to all electronic sign performance standards. Messages will remain static for a minimum of four seconds per message and instantaneous transitions will be used from one message to the next. The sign will display only static messages and will be equipped with auto-dimming technology to reduce intensity of light as ambient light decreases. There will also be a default mode to turn off the display if it malfunctions.

In addition to the Adams County Development Standards and Regulations, the proposed billboard must show compliance with all the requirements of the Colorado Outdoor Advertising Act, C.R.S. 43-1-401 et. Seq. and the Colorado rules and regulations promulgated thereunder by the Colorado Department of Transportation (CDOT). CDOT reviewed the subject request and stated an Outdoor Advertising permit will be required after approval from the County (i.e a local jurisdiction).

**Future Land Use Designation/Comprehensive Plan:**

The future land use designation on the property is Mixed Use Employment. Per Chapter 5 of the Adams County Comprehensive Plan, the purpose of the Mixed-Use Employment future land use designation is to accommodate a range of employment uses with a mix of supporting uses to serve employment needs. In addition, Mixed-Used Employment areas are designated in locations that have transportation access and visibility but are not suitable for residential development. Mixed-Use Employment areas may include offices, light manufacturing, distribution, indoor warehousing, clean industry, and supporting retail businesses.

The subject property is located within the Welby Subarea Plan. This property is considered to be part of the South Welby Area of this plan, which is identified as transitioning to industrial uses.

The recommendation of approval for the subject billboard is based strictly on the criteria of approval for a Conditional Use Permit; however, it is important to discuss the project's compliance with the applicable subarea plans. The Comprehensive Plan and its adopted subarea plans are intended to provide guidance for future development within the County. The subject parcel is located within the Southwest Area Framework Plan. The Southwest Area Framework Plan is an adopted plan in the Comprehensive plan. The plan includes a Policy 14.7 to *Enhance the area's role as an important County Gateway*. Strategies in completing the goals include:

1. 14.7.a. *Entryway Image* – Initiate landscaping, streetscaping, and buffering programs to improve the entryway image of the County as viewed from I-70, I-25, and I-76 and key highway exits into the County;
2. 14.7.b. *Screening and Buffering* – Require improved buffering for new development along the I-70, I-25, and I-76 corridors, and require screening for new outdoor storage and activities visible from I-70, I-25, and I-76; and
3. 14.7.c *Signs* – Review and update the sign regulation provisions, including control of off-premise signs, applicable to private lands visible from I-70, I-25, and I-76 and key highway exits into the County.

Strategy 14.7.c suggests that the County should update the sign code to potentially control the number of off-premise signs permitted along gateways into Adams County. The plan also suggests that setbacks and buffers from I-25 and I-76 should be greater than in other areas of the County.

**Surrounding Zoning Designations and Existing Use Activity:**

<p style="text-align: center;"><b>Northwest I-1 and C-3 Office and Warehousing</b></p>	<p style="text-align: center;"><b>North I-2 Business Park, Office, and Warehousing</b></p>	<p style="text-align: center;"><b>Northeast I-3 Office and Warehousing</b></p>
<p style="text-align: center;"><b>West R-2 Interstate Right-of-Way and Small Lakes or Drainage Facilities</b></p>	<p style="text-align: center;"><b>Subject Property C-5 Business Park, Office, and Warehousing</b></p>	<p style="text-align: center;"><b>East I-1 Manufacturing, Office, and Warehousing</b></p>
<p style="text-align: center;"><b>Southwest I-2 Interstate Right-of-Way and Small Lakes or Drainage Facilities</b></p>	<p style="text-align: center;"><b>South A-1 and I-1 Vacant Land and a Single- Family Residence</b></p>	<p style="text-align: center;"><b>Southeast I-1 Manufacturing, Office, and Warehousing</b></p>

**Compatibility with the Surrounding Area:**

The subject property is located at the southeastern corner of Washington Street and I-270. The surrounding properties include a mix of zone districts but are primarily located within the Industrial-1 (I-1) zone district and are developed for business park, office, warehousing, and manufacturing uses. There are scattered single-family residential uses throughout the area, many of which remain within the Agriculture-1 (A-1) zone district, including directly south of the subject property. Directly to the east of the subject property is the TruStile Doors headquarters, which includes manufacturing, office, and warehousing uses. The properties to the north and across Interstate 270 are developed and used commercially for multi-tenant buildings. I-270 is located directly to the north of the site, while the I-25 ramps that provide access to the interstate highway are located to the west of the site. The properties to the immediate south are mostly vacant, except one single-family residential dwelling located to the southeast of the site. Overall, the subject request for a an off-premise advertising device is generally compatible with the surrounding area and uses.

**Planning Commission Update:**

The Planning Commission considered this request on January 28, 2021, and recommended approval with a 7-0 vote and 8 Findings-of-Fact, 6 Conditions, and 6 Notes to the applicant. No members of the public spoke in support or opposition of the request during the public hearing.

At the hearing, the Planning Commission inquired about the minimum four seconds that each message must be displayed on the billboard as compared to the optimal ten seconds that the County’s Development Standards and Regulations recommends that each message should be displayed on the billboard. The Planning Commission also acknowledged that Conditional Use Permit approval for the same use on this site was previously considered and granted through public hearing in 2019.

**Staff Recommendation:**

**Based upon the application, the criteria for rezoning approval, and a recent site visit, staff recommends Approval of this request with 8 Findings-of-Fact, 6 Conditions, and 3 Notes:**

**Recommended Findings-of-Fact:**

1. The conditional use is permitted in the applicable zone district.
2. The conditional use is consistent with the purposes of these standards and regulations.
3. The conditional use will comply with the requirements of these standards and regulations including, but not limited to, all applicable performance standards.
4. The conditional use is compatible with the surrounding area, harmonious with the character of the neighborhood, not detrimental to the immediate area, not detrimental to the future development of the area, and not detrimental to the health, safety, or welfare of the inhabitants of the area and the County. In making this determination, the Planning Commission and the Board of County Commissioners shall find, at a minimum, that the conditional use will not result in excessive traffic generation, noise, vibration, dust, glare, heat, smoke, fumes, gas, odors, or inappropriate hours of operation.
5. The conditional use permit has addressed all off-site impacts.
6. The site is suitable for the conditional use including adequate usable space, adequate access, and absence of environmental constraints.
7. The site plan for the proposed conditional use will provide the most convenient and functional use of the lot including the parking scheme, traffic circulation, open space, fencing, screening, landscaping, signage, and lighting.
8. Sewer, water, storm water drainage, fire protection, police protection, and roads are to be available and adequate to serve the needs of the conditional use as designed and proposed.

**Recommended Conditions of Approval:**

1. The applicant must show compliance with all the requirements of the Colorado Outdoor Advertising Act, C.R.S. 43-1-401 et. Seq. and the Colorado rules and regulations promulgated thereunder by the Colorado Department of Transportation.
2. The applicant shall obtain an Outdoor Advertising Permit from the Colorado Department of Transportation.
3. The applicant shall obtain a building permit from Adams County for the billboard, including all required building permit inspections.
4. Each message displayed on the billboard shall remain static for a minimum of four (4) seconds and must transition immediately to the next message displayed.
5. The leading edge of the billboard sign pole must be placed equal to or greater than the height of the structure from the north property line, in accordance with the County's Development Standards and Regulations. A site plan demonstrating compliance shall be submitted with the building permit application.
6. The approval of the off-premise sign shall expire February 23, 2031, unless renewed.

**Recommended Notes to the Applicant:**

1. All applicable building, zoning, health, fire, and engineering requirements and codes shall be adhered to with this request. The applicant may submit an alternative design that can be approved through a Minor Amendment to this Conditional Use Permit by staff, as

long as the design complies with the Adams County Development Standards and Regulations at the time of building permit application.

2. The Conditional Use Permit shall expire on February 23, 2022, if sign permits are not obtained from Adams County.
3. Any sign or attractive device which includes animated images or graphics, scrolling messages, video, moving images similar to television images, emits audible sounds, employs stereopticon, or includes motion picture projection is prohibited.

**CITIZEN COMMENTS**

Notifications Sent	Comments Received
243	0

All property owners and occupants within 1,000’ of the subject property were notified of the request. As of writing this report, staff has received 0 responses from neighboring property owners or residents.

**COUNTY AGENCY COMMENTS**

Staff reviewed the request and had no concerns with the proposed conditional use permit. The Engineering Review confirmed that the proposed location is not in a floodplain, and the Right-of-Way Review confirmed through the submitted Title Commitment that no other party’s interests are being encroached upon as a result of this proposal.

**REFERRAL AGENCY COMMENTS**

**Responding with Concerns:**

None.

**Responding without Concerns:**

Colorado Department of Transportation  
 Regional Transportation District  
 Tri-County Health Department  
 Xcel Energy

**Notified but not Responding / Considered a Favorable Response:**

Adams 12 Five Star Schools  
 Adams County Attorney’s Office  
 Adams County Fire Protection District  
 Adams County School District 14  
 Adams County Sheriff’s Office  
 Colorado Department of Public Health and Environment  
 Century Link, Inc.  
 City of Federal Heights  
 City of Federal Heights Water and Sanitation Department  
 City of Thornton  
 Colorado Division of Wildlife  
 Comcast  
 Commerce City Planning Division



Crestview Water and Sanitation  
Federal Heights Fire Department  
Mapleton School District #1  
Metro Wastewater Reclamation  
North Pecos Water and Sanitation District  
North Washington Street Water and Sanitation District  
Perl Mack Neighborhood Group  
South Adams County Fire District  
South Adams County Water and Sanitation District  
Thornton Fire Department  
Union Pacific Railroad  
Welby Citizen Group  
Westminster School District #50

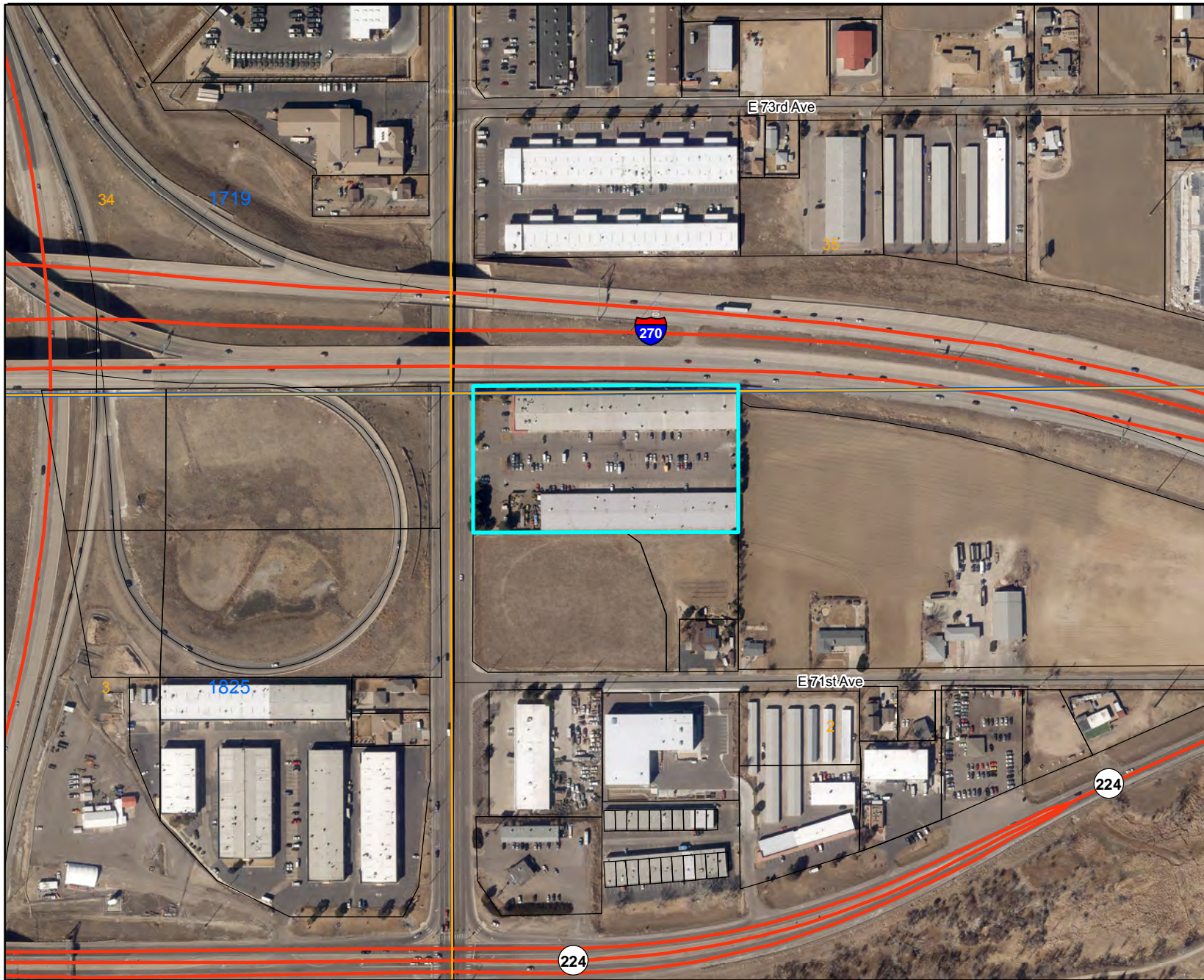

**Legend**

- Railroad
- Major Water
- Zoning Line
- Sections

**Zoning Districts**

- A-1
- A-2
- A-3
- R-E
- R-1-A
- R-1-C
- R-2
- R-3
- R-4
- M-H
- C-0
- C-1
- C-2
- C-3
- C-4
- C-5
- I-1
- I-2
- I-3
- CO
- PL
- AV
- DIA
- P-U-D
- P-U-D(P)
- Conditions

**Aerial Map**

**Case Number: RCU2020-00014**



For display purposes only.



This map is made possible by the Adams County GIS group, which assumes no responsibility for its accuracy

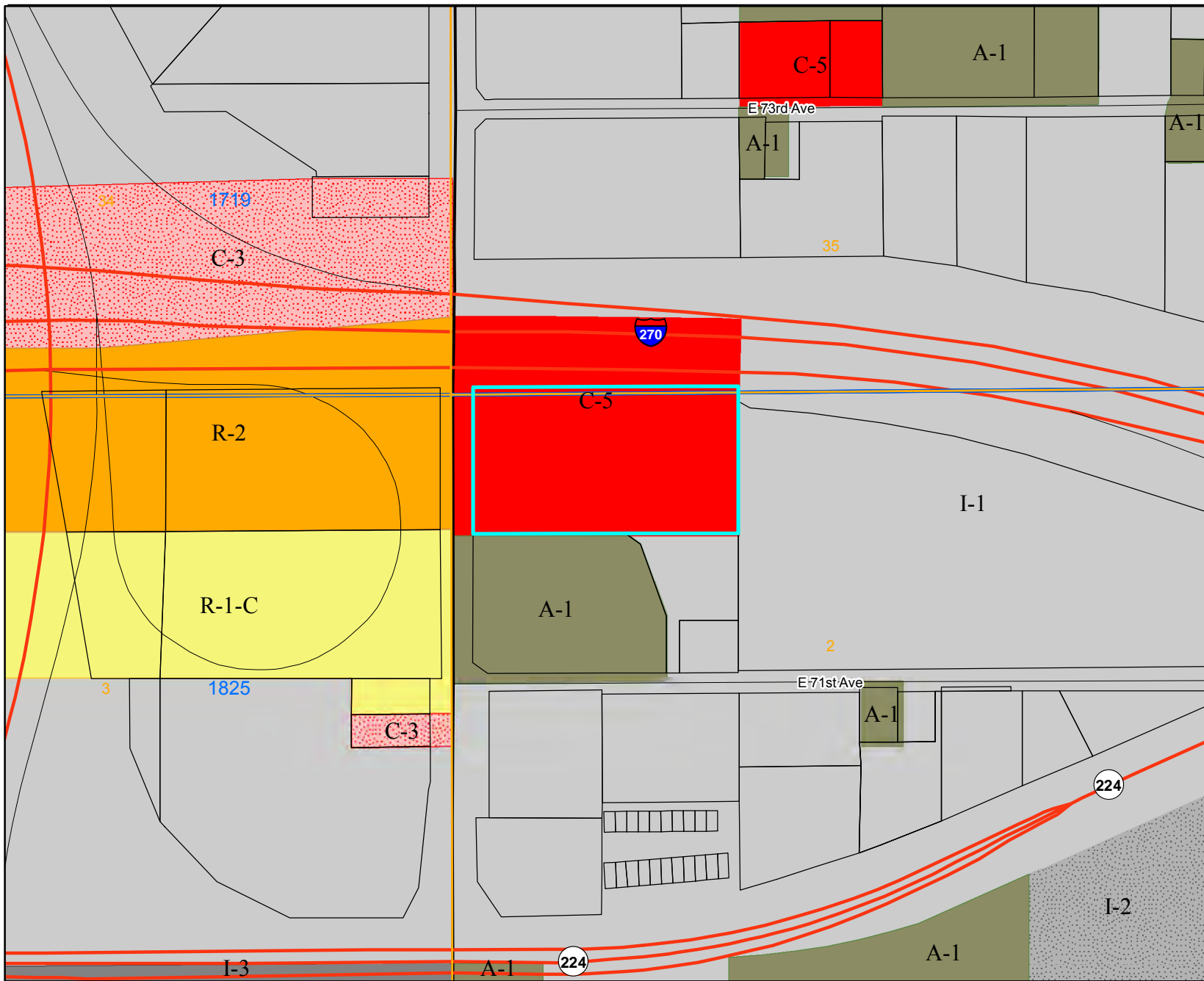

**Legend**

- Railroad
- Major Water
- Zoning Line
- Sections
- Zoning Districts**
- A-1
- A-2
- A-3
- R-E
- R-1-A
- R-1-C
- R-2
- R-3
- R-4
- M-H
- C-0
- C-1
- C-2
- C-3
- C-4
- C-5
- I-1
- I-2
- I-3
- CO
- PL
- AV
- DIA
- P-U-D
- P-U-D(P)
- Conditions

**Zoning Map**

**Case Number: RCU2020-00014**



For display purposes only.



This map is made possible by the Adams County GIS group, which assumes no responsibility for its accuracy

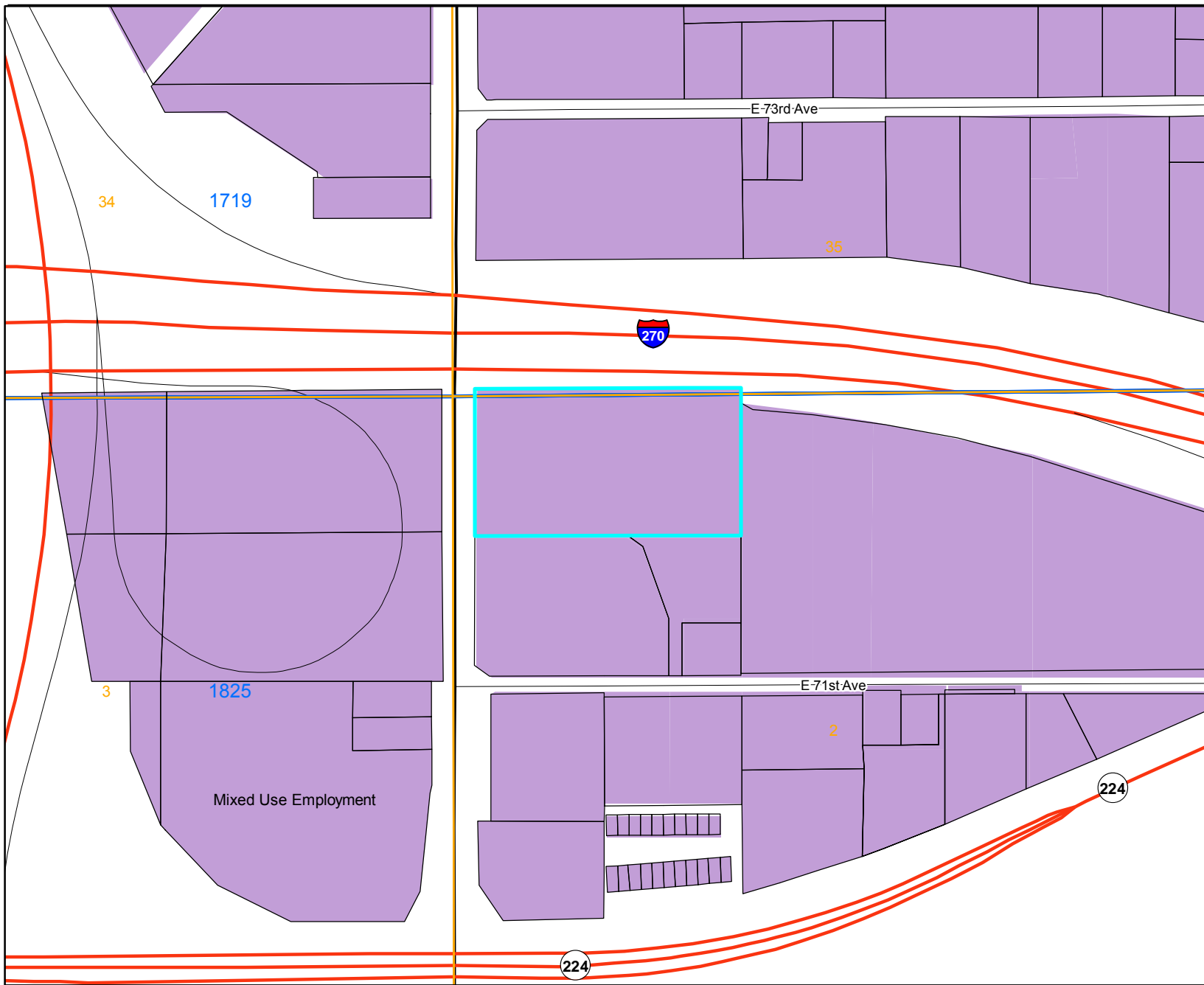

**Legend**

- Railroad
- Major Water
- Zoning Line
- Sections
- Zoning Districts**
- A-1
- A-2
- A-3
- R-E
- R-1-A
- R-1-C
- R-2
- R-3
- R-4
- M-H
- C-0
- C-1
- C-2
- C-3
- C-4
- C-5
- I-1
- I-2
- I-3
- CO
- PL
- AV
- DIA
- P-U-D
- P-U-D(P)
- Conditions

**Future Land Use Planning Map**  
**Case Number: RCU2020-00014**



For display purposes only.



This map is made possible by the Adams County GIS group, which assumes no responsibility for its accuracy

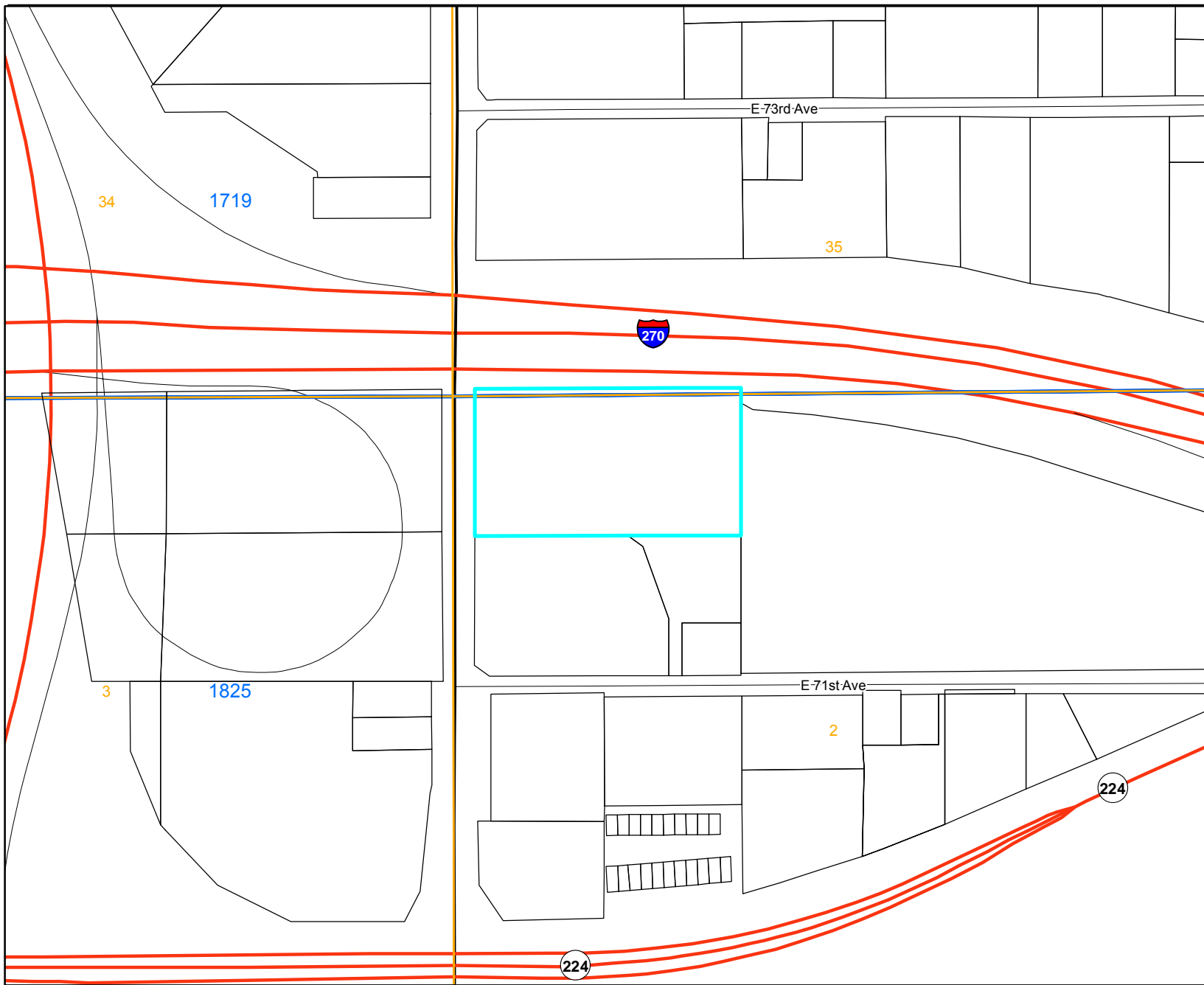

**Legend**

- Railroad
- Major Water
- Zoning Line
- Sections
- Zoning Districts**
- A-1
- A-2
- A-3
- R-E
- R-1-A
- R-1-C
- R-2
- R-3
- R-4
- M-H
- C-0
- C-1
- C-2
- C-3
- C-4
- C-5
- I-1
- I-2
- I-3
- CO
- PL
- AV
- DIA
- P-U-D
- P-U-D(P)
- Conditions

**Simple Map**

**Case Number: RCU2020-00014**



For display purposes only.



This map is made possible by the Adams County GIS group, which assumes no responsibility for its accuracy

APPLICATION FOR CONDITIONAL USE PERMIT APPROVAL  
FOR OFF-PREMISE ADVERTISING DEVICE (BILLBOARD)

Applicant: StreetMedia Group, LLC

Location: 7190 North Washington Street

**WRITTEN EXPLANATION OF THE PROJECT**

StreetMedia Group proposes to conduct an off-premise advertising device (billboard) at the south side of I-270 and east side of North Washington Street, which is commonly known as 7190 North Washington Street ("SUBJECT PROPERTY") (PIN 0182502202021) in the location shown on the enclosed site plan. The Subject Property is 4.32 acres in area and is zoned C-5 ("DISTRICT"). The existing use of the Subject Property is office and warehouse for multiple commercial tenants, a permitted use in the District. The Subject Property is located in a developing light industrial area.

Billboards are allowed in the District with an approved Conditional Use Permit ("CUP"). CUPs are subject to the approval criteria set out in Section 2-02-09-06, Adams County Development Standards and Regulations ("ADCO STANDARDS"). Billboard performance standards are set out in ADCO Standards § 4-15. No other ADCO Standards apply during the conditional use permit process.

The proposed billboard complies with all applicable CUP and performance standards, as follows:

**CUP STANDARD #1.** THE CONDITIONAL USE IS PERMITTED IN THE APPLICABLE ZONE DISTRICT. Billboards are allowed as a conditional use in the District.

**CUP STANDARD #2.** THE CONDITIONAL USE IS CONSISTENT WITH THE PURPOSES OF [THE ADCO STANDARDS].

The proposed billboard is allowed as a conditional use in the District. The proposed billboard meets all applicable performance standards. As such, it is consistent with the purposes of the ADCO Standards.

**CUP STANDARD #3.** THE CONDITIONAL USE WILL COMPLY WITH THE REQUIREMENTS OF [THE ADCO STANDARDS], INCLUDING, BUT NOT LIMITED TO, ALL APPLICABLE PERFORMANCE STANDARDS.

The proposed billboard complies with the requirements of ADCO Standards § 4-15, which set out the performance standards for billboards, as follows:

STANDARD	COMPLIANCE STATEMENT
4-15-03	The Subject Property will contain only one billboard with not more than two faces.
4-15-04	The area of each sign face will not exceed 300 square feet.
4-15-05	The height of the sign does not exceed 40 feet, measured as provided in ADCO Standards § 4-14-05.

STANDARD	COMPLIANCE STATEMENT
4-15-06-02	Messages displayed on the electronic sign face(s) will remain static for a minimum of four seconds per message and instantaneous transitions will be used from one message to the next. The electronic sign face(s) will have a default mode to turn off the display if it malfunctions. Subsection 4-15-06-02 #4 is unenforceable as written, but the display will comply with the spirit of that standard (and with CDOT standards) as shown in the photometric plans that are attached to the site plan.
4-15-07 #1	The sign is separated from off-premises signs on the same side of the highway a distance that exceeds the 2,000 foot minimum spacing set out in Section 4-15-07 #1, ADCO Standards.
4-15-07 #2	The leading edge of the pole of the proposed billboard is set back a distance equal to the height of the billboard. A variation in the standard setback requirement of, ADCO Standards § 4-15-07 #2 is not requested with this application.
4-15-07 #3	Acknowledged
4-15-07 #4	Acknowledged
4-15-07 #5	This item is a restatement of requirements in ADCO Standards § 4-15-06-02. See response provided to said standards, above.
4-15-07 #6	As shown on the attached site plan, the sign faces will be aligned back to back, and spaced not more than 3.5 feet from each other. The applicant understands that the County is currently processing amendments to the ADCO Standards that may allow for a "V-shaped" configuration of sign faces. The applicant respectfully requests that the following note be added to the conditional use permit should this application be approved by the Board of County Commissioners:  <p style="margin-left: 40px;">All applicable building, zoning, health, fire, and engineering requirements and codes shall be adhered to with this request. The applicant may submit an alternative design that can be approved through a Minor Amendment to this Conditional Use Permit by staff, as long as the design complies with the Adams County Development Standards and Regulations at the time of building permit application.</p>
4-15-07 #7	Acknowledged

**CUP STANDARD #4.** THE CONDITIONAL USE IS COMPATIBLE WITH THE SURROUNDING AREA, HARMONIOUS WITH THE CHARACTER OF THE NEIGHBORHOOD, NOT DETRIMENTAL TO THE IMMEDIATE AREA, NOT DETRIMENTAL TO THE FUTURE DEVELOPMENT OF THE AREA, AND NOT DETRIMENTAL TO THE HEALTH, SAFETY, OR WELFARE OF THE INHABITANTS OF THE AREA AND THE

COUNTY. IN MAKING THIS DETERMINATION, THE PLANNING COMMISSION AND THE BOARD OF COUNTY COMMISSIONERS SHALL FIND, AT A MINIMUM, THAT THE CONDITIONAL USE WILL NOT RESULT IN EXCESSIVE TRAFFIC GENERATION, NOISE, VIBRATION, DUST, GLARE, HEAT, SMOKE, FUMES, GAS, ODORS, OR INAPPROPRIATE HOURS OF OPERATION.

The proposed billboard is consistent with the industrial character of the area in which it is located. It will allow for not only advertising space for businesses in the area, but also for "help wanted," public service, and emergency messaging. As such, it advances the health, safety, and welfare of the inhabitants of the area, the County, and the region.

The sign will produce no additional traffic, noise, vibration, heat, smoke, fumes, gas, or odors. Light emissions from the sign during nighttime hours will be in compliance with Colorado Department of Transportation ("CDOT") and Adams County standards.

**CUP STANDARD #5.** THE CONDITIONAL USE PERMIT HAS ADDRESSED ALL OFF-SITE IMPACTS.

The sign will comply with all applicable lighting requirements of the County and CDOT, and will be constructed to building code requirements. The sign is located outside of sight distance triangles. As such, it does not create off-site impacts.

**CUP STANDARD #6.** THE SITE IS SUITABLE FOR THE CONDITIONAL USE INCLUDING ADEQUATE USABLE SPACE, ADEQUATE ACCESS, AND ABSENCE OF ENVIRONMENTAL CONSTRAINTS.

The Subject Property is suitable for the proposed billboard. The existing use of the Subject Property is commercial office and warehouse. There is room on the Subject Property to include the proposed billboard without interference with the existing use. There are no environmental constraints on the Subject Property that would interfere with the proposed billboard.

**CUP STANDARD #7.** THE SITE PLAN FOR THE PROPOSED CONDITIONAL USE WILL PROVIDE THE MOST CONVENIENT AND FUNCTIONAL USE OF THE LOT INCLUDING THE PARKING SCHEME, TRAFFIC CIRCULATION, OPEN SPACE, FENCING, SCREENING, LANDSCAPING, SIGNAGE, AND LIGHTING.

The attached site plan shows the sign placed in a location that provides for the most functional use of the lot in terms of parking, circulation, open space, fencing, screening, landscaping, signage, and lighting. The sign does not interfere with the principal use, and is optimized for safe view angles from the adjacent highway.

**CUP STANDARD #8.** SEWER, WATER, STORM WATER DRAINAGE, FIRE PROTECTION, POLICE PROTECTION, AND ROADS ARE TO BE AVAILABLE AND ADEQUATE TO SERVE THE NEEDS OF THE CONDITIONAL USE AS DESIGNED AND PROPOSED.

The listed services are currently available to the Subject Property to serve the principal use, and there will be no perceptible increase in demand for any of the listed services as a result of the installation of a billboard.





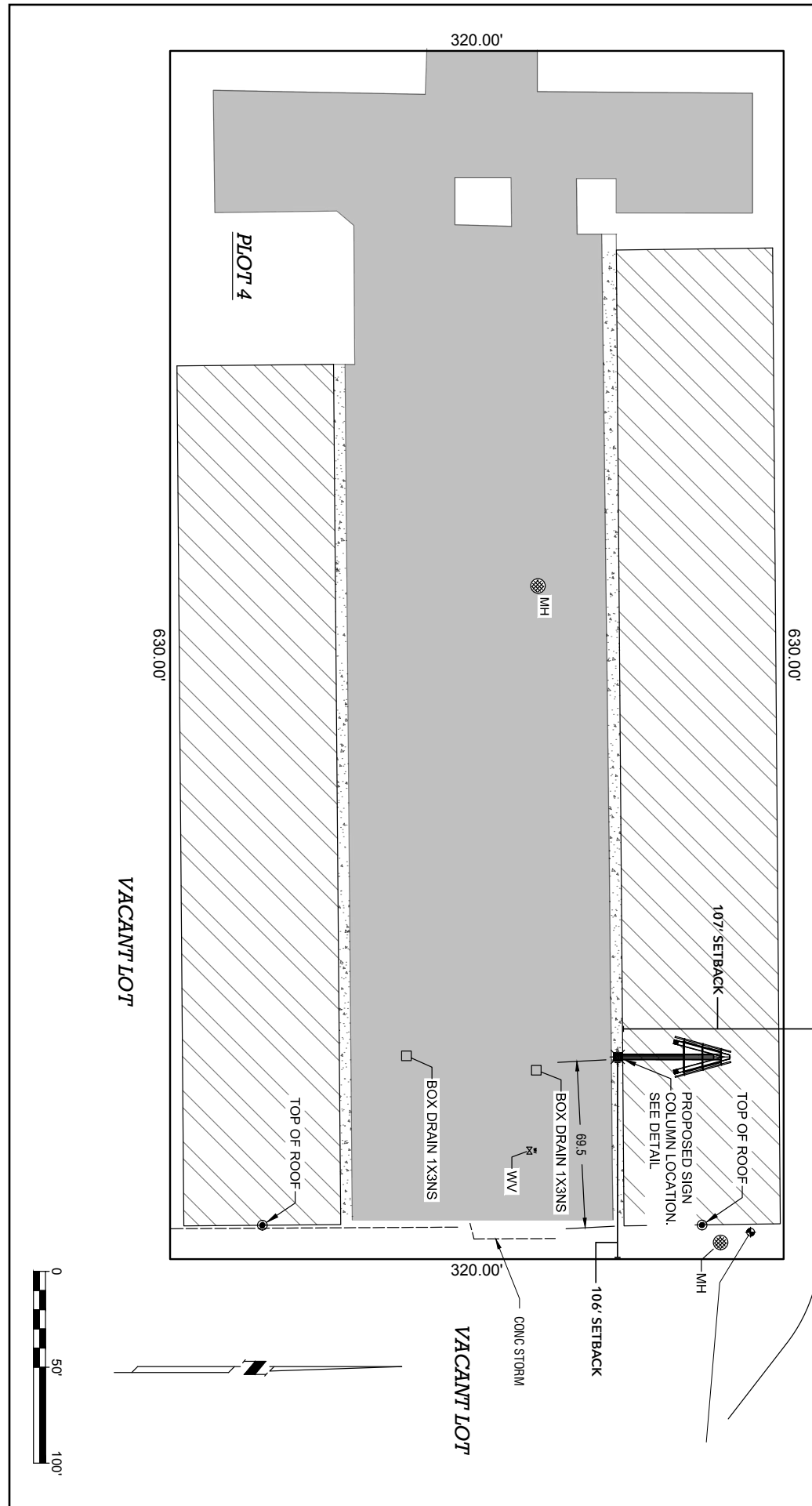

I-76

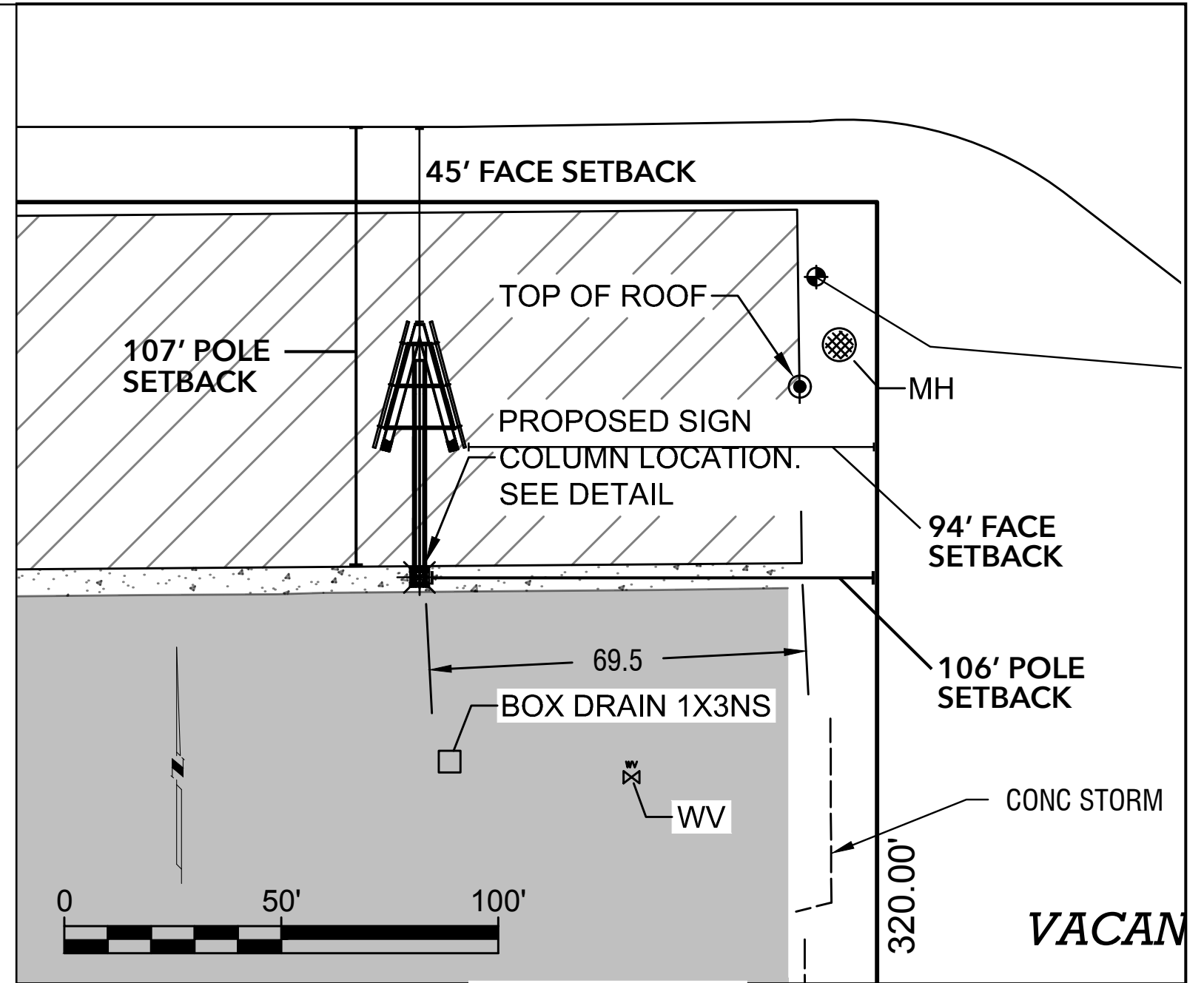

**SURVEYOR'S CERTIFICATION:**

I, JOSEPH W. STICE III BEING A REGISTERED LAND SURVEYOR IN THE STATE OF COLORADO, PLS 36072, DO HEREBY CERTIFY THAT IN MAY 2018, A SURVEY WAS PERFORMED TO ESTABLISH THE LOCATION OF A NEW BILLBOARD, THE GRAPHIC REPRESENTATIONS SHOWN HEREIN OF THE DESCRIBED LOCATION WAS COMPLETED UNDER MY DIRECT SUPERVISION, AND WERE ACCURATE AT THE TIME OF THE SURVEY.

FOR AND ON BEHALF OF TIMBERLINE SURVEYING:  
JOSEPH W. STICE III

<p><b>SITE PLAN</b> 7190 WASHINGTON STREET</p>
<p><b>StreetMediaGroup</b> 161 Saturn Dr., Ste 5   Fort Collins, CO 80525</p>

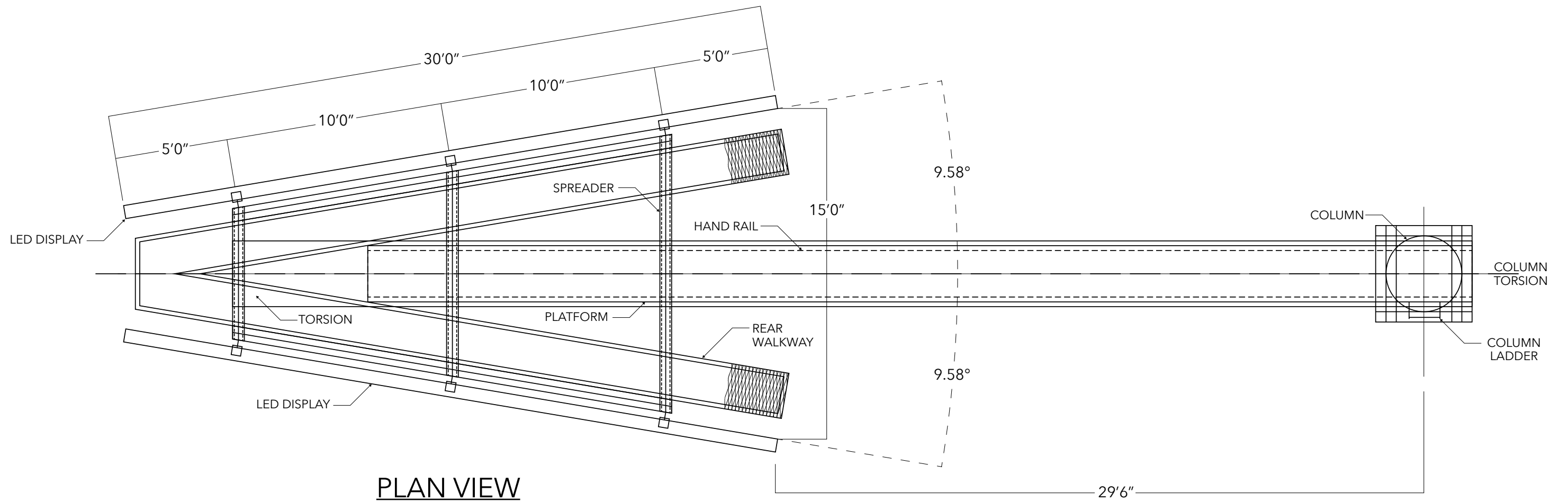

PLAN VIEW

**SITE PLAN**  
7190 WASHINGTON STREET

**StreetMediaGroup**  
161 Saturn Dr., Ste 5 | Fort Collins, CO 80525



No existing billboards within 3,000 ft.

PROPOSED BILLBOARD

No existing billboards within 3,000 ft.

**SITE PLAN**  
7190 WASHINGTON STREET

**StreetMediaGroup**  
161 Saturn Dr., Ste 5 | Fort Collins, CO 80525



No existing billboards within 3,000 ft.

PROPOSED BILLBOARD

No existing billboards within 3,000 ft.

**SITE PLAN**  
7190 WASHINGTON STREET

**StreetMediaGroup**  
161 Saturn Dr., Ste 5 | Fort Collins, CO 80525



**PHOTOSIMULATION**  
7190 WASHINGTON STREET

**StreetMediaGroup**  
161 Saturn Dr., Ste 5 | Fort Collins, CO 80525



©2016 Google

**PHOTOSIMULATION**  
7190 WASHINGTON STREET

**StreetMediaGroup**  
161 Saturn Dr., Ste 5 | Fort Collins, CO 80525

**Yellow Lines** illustrate how the sign brightness drops rapidly from **80% to 20% to 1%** due to the incorporation of **Siteline Blocking Louvers Technology**.

**Yellow** represents calculated illuminance figures at selected locations in **foot-candles[fc]**. A full moon has a light impact of approximately **0.03 fc**. A value less than this is considered **negligible**.

**Parameters:**

- Display Luminance = 300 NITS

Calculations made by Shehab Rustom, Engineering Product Manager





### Development Team Review Comments

The following comments have been provided by reviewers of your land use application. At this time, a resubmittal of your application is required before this case is ready to be scheduled for public hearing.

To prepare your resubmittal, you will be expected to provide:

- A response to each comment with a description of the revisions and the page of the response on the site plan;
- Any revised plans or renderings; and
- A list identifying any additional changes made to the original submission other than those required by staff.

Resubmittal documents must be provided in person to the One-Stop Customer Service Center of the Community and Economic Development Department. The following items will be expected by our One-Stop Customer Service Center:

- One paper copy of all new materials
  - Paper copies shall not exceed 11"x17" (exception shall be made only for construction drawings or engineering plan review)
  - All paper copies shall be accompanied by the attached Resubmittal Form
- One digital copy of all new materials
  - All digital materials shall be in a single PDF document
  - The single PDF document shall be bookmarked
  - If a Subdivision Improvements Agreement, Legal Description, or Development Agreement is required, then an additional Microsoft Word version of these documents shall also be provided



## Re-submittal Form

Case Name/ Number: \_\_\_\_\_

Case Manager: \_\_\_\_\_

### Re-submitted Items:

- Development Plan/ Site Plan
- Plat
- Parking/ Landscape Plan
- Engineering Documents
- Subdivision Improvements Agreement
- Other: \_\_\_\_\_

**\* All re-submittals must have this cover sheet and a cover letter addressing review comments.**

**Please note the re-submittal review period is 21 days.**

The cover letter must include the following information:

- Restate each comment that requires a response
- Provide a response below the comment with a description of the revisions
- Identify any additional changes made to the original document

For County Use Only:

Date Accepted:

Staff (accepting intake):

Resubmittal Active: ~~Addressing, Building Safety, Neighborhood Services,~~

~~Engineering, Environmental, Parks, Planner, ROW, SIA - Finance, SIA - Attorney~~

**Commenting Division:** Planning

**Resubmittal Required**

**Name of Reviewer:** Holden Pederson

**Email and Phone Number:** [HPederson@adcogov.org](mailto:HPederson@adcogov.org) / 720-523-6847

PLN1: Electronic billboard would be visible from I-270. According to the applicant, the existing use of the property is office and warehousing for multiple tenants. Off-premise advertising devices are permitted with an approved Conditional Use Permit in the C-5 zone district.

PLN2: The subject request meets the following performance standards for off-premise advertising devices (billboards):

- The property would contain only 1 two-faced off-premise advertising device (Section 4-15-03).
- The maximum size of the billboard face would not exceed 300 square feet (Section 4-15-04).
- The maximum height of the billboard would not exceed 40 feet and the lowest point of the sign face would be at least 8 feet above the ground (Section 4-15-06).
- All electronic sign restrictions have been confirmed and acknowledged by the applicant (Section 4-15-06-02).
- The billboard would be separated by a minimum of 2,000 linear feet from the nearest off-premise sign on the same side of the road or highway (Section 4-15-07).
- The two faces of the billboard would be back to back and would not be greater than 3.5 feet from one another (Section 4-15-07).

PLN3: Applicant has requested that the following note be added to the Conditional Use Permit if the application is approved by the Board of County Commissioners in order to address future code amendments that would allow a "V-shaped" configuration of sign-faces: "All applicable building, zoning, health, fire, and engineering requirements and codes shall be adhered to with this request. The applicant may submit an alternative design that can be approved through a Minor Amendment to this Conditional Use Permit by staff, as long as the design complies with the Adams County Development Standards and Regulations at the time of building permit application."

PLN4: Applicant must provide a site plan that shows the setback of the proposed billboard to the exact location of the property line. A higher quality site plan is required than the current aerial photo that was provided in the application submittal and must clearly show all property lines and setback distances. Applicant must also confirm whether they are measuring the setback from the leading edge of the pole or the leading edge of the sign face.

PLN5: Applicant must provide Certificate of Notice to Mineral Estate Owners/and Lessees, as well as Certificate of Surface Development as part of the resubmittal. These documents are required 30 days before the initial public hearing is held. They are listed as items #10 and 11 within the Conditional Use Permit application checklist and are included on pages 6 through 9 on the application.

**Commenting Division:** Engineering

**Complete**

**Name of Reviewer:** Greg Labrie

**Email and Phone Number:** [GLabrie@adcogov.org](mailto:GLabrie@adcogov.org) / 720-523-6824

ENG1: The proposed location is not in a floodplain. A floodplain use permit is not required. If the land use application is approved, the applicant must apply for a building permit to construct the sign on site.

**Commenting Division:** Right-of-Way

**Resubmittal Required**

**Name of Reviewer:** Mark Alessi

**Email and Phone Number:** [MAlessi@adcogov.org](mailto:MAlessi@adcogov.org) / 720-523-6825

ROW1: Please submit a title commitment which should be used to depict the applicable recordings on the plat. Send Adams County a copy of the title commitment with your application dated no later than 30 days to review in order to ensure that any other party's interests are not encroached upon. All applicable easements/exceptions should be accurately shown and labeled on the plat.



**COLORADO**  
Department of  
Transportation

Region «Region» Traffic Section  
2829 West Howard Place  
«City», Colorado 80204  
Phone (303) 512-4272 Fax (303) 757-9886

July 14, 2020

Holden Pederson  
Planner II  
Community and Economic Development Department  
4430 South Adams County Parkway, Suite W200A  
Brighton, CO 80601-8216

**RE: Case Name: Street Media Washington Billboard CUP**  
**Case Number: RCU2020-00014**

Dear Mr. Pederson:

I have reviewed the referral for the CUP to allow an electronic billboard in the C-5 zone district, visible from I-270, located at 7190 N. Washington St., and have the following comments:

- This proposed digital billboard sign, which will advertise to Interstate 270, will require an Outdoor Advertising Permit from CDOT.
- This proposed sign must meet all Applicable rules governing outdoor advertising in Colorado per 2 CCR 601-3.
- Application packet, when completed, should be sent to Jacquelyn Jobe at 2829 W. Howard Place, 2<sup>nd</sup> Floor, Denver, CO 80204.

Thank you for the opportunity to review this referral.

Please feel free to contact me at the office listed above if I can of any further assistance in this or any other matter.

Sincerely,

Jacquelyn Jobe  
Region 1 Outdoor Advertising Representative  
(303) 512-4272



**From:** [Woodruff, Clayton](#)  
**To:** [Holden Pederson](#)  
**Subject:** RE Street Media Washington Billboard CUP  
**Date:** Tuesday, June 30, 2020 8:26:30 AM

---

Please be cautious: This email was sent from outside Adams County

Holden,

The RTD has no comment on this project.



**C. Scott Woodruff**  
**Engineer III**

Regional Transportation District  
1560 Broadway, Suite 700, FAS-73 | Denver, CO 80202

o 303.299.2943 | m 303-720-2025  
[clayton.woodruff@rd-denver.com](mailto:clayton.woodruff@rd-denver.com)



July 1, 2020

Holden Pederson  
Adams County Community and Economic Development  
4430 South Adams County Parkway, Suite W2000A  
Brighton, CO 80601

RE: StreetMedia Washington Billboard, RCU2020-00014  
TCHD Case No. 6345

Dear Mr. Pederson,

Thank you for the opportunity to review and comment on the Conditional Use Permit for an electronic billboard in the Commercial-5 (C-5) zone district located at 7190 N Washington Street. Tri-County Health Department (TCHD) staff has reviewed the application for compliance with applicable environmental and public health regulations and principles of healthy community design. After reviewing the application, TCHD has no comments.

Please feel free to contact me at 720-200-1585 or [ahenrich@tchd.org](mailto:ahenrich@tchd.org) if you have any questions.

Sincerely,

A handwritten signature in black ink that reads "AHF".

Annemarie Heinrich Fortune, MPH/MURP  
Land Use and Built Environment Specialist

cc: Sheila Lynch, Monte Deatrich, TCHD



Right of Way & Permits  
1123 West 3<sup>rd</sup> Avenue  
Denver, Colorado 80223  
Telephone: 303.571.3306  
Facsimile: 303.571.3284  
donna.l.george@xcelenergy.com

July 16, 2020

Adams County Community and Economic Development Department  
4430 South Adams County Parkway, 3<sup>rd</sup> Floor, Suite W3000  
Brighton, CO 80601

Attn: Holden Pederson

**Re: StreetMedia Washington Billboard, Case # RCU2020-00014**

Public Service Company of Colorado's (PSCo) Right of Way & Permits Referral Desk has reviewed the documentation for **StreetMedia Washington Billboard** and has **no apparent conflict**.

Please be aware PSCo owns and operates existing natural gas service facilities near the base of the proposed sign. As a safety precaution, PSCo would like to remind the developer to call the Utility Notification Center by dialing 811 for utility locates prior to construction. Use caution and hand dig when excavating within 18-inches of each side of the marked facilities. Please be aware that all risk and responsibility for this request are unilaterally that of the Applicant/Requestor.

Donna George  
Right of Way and Permits  
Public Service Company of Colorado dba Xcel Energy  
Office: 303-571-3306 – Email: donna.l.george@xcelenergy.com





## Development Team Review Comments

The following comments have been provided by reviewers of your land use application. At this time, a resubmittal of your application is required before this case is ready to be scheduled for public hearing.

To prepare your resubmittal, you will be expected to provide:

- A response to each comment with a description of the revisions and the page of the response on the site plan;
- Any revised plans or renderings; and
- A list identifying any additional changes made to the original submission other than those required by staff.

Resubmittal documents must be provided electronically through e-mail or a flash drive delivered to the One-Stop Customer Service Center. The following items will be expected by our One-Stop Customer Service Center:

- One digital copy of all new materials
  - All digital materials shall be in a single PDF document
  - The single PDF document shall be bookmarked
  - If a Subdivision Improvements Agreement, Legal Description, or Development Agreement is required, then an additional Microsoft Word version of these documents shall also be provided
  - Electronic copies can be emailed to [epermitcenter@adcogov.org](mailto:epermitcenter@adcogov.org) as a PDF attachment. If the files are too large to attach, the email should include an unlocked Microsoft OneDrive link. Alternatively, the resubmittal can be delivered to the One-Stop counter on a flash drive.



## Re-submittal Form

Case Name/ Number: \_\_\_\_\_

Case Manager: \_\_\_\_\_

### Re-submitted Items:

- Development Plan/ Site Plan
- Plat
- Parking/ Landscape Plan
- Engineering Documents
- Subdivision Improvements Agreement
- Other: \_\_\_\_\_

**\* All re-submittals must have this cover sheet and a cover letter addressing review comments.**

**Please note the re-submittal review period is 21 days.**

The cover letter must include the following information:

- Restate each comment that requires a response
- Provide a response below the comment with a description of the revisions
- Identify any additional changes made to the original document

For County Use Only:

Date Accepted:

Staff (accepting intake):

Resubmittal Active: Addressing, Building Safety, Neighborhood Services,

Engineering, Environmental, Parks, Planner, ROW, SIA - Finance, SIA - Attorney

**RCU2020-00013**

**Commenting Division:** Planning

**Resubmittal Required**

**Name of Reviewer:** Holden Pederson

**Email and Phone Number:** [HPederson@adcogov.org](mailto:HPederson@adcogov.org) / 720-523-6847

PLN1: Applicant must still provide the Certificate of Notice to Mineral Estate Owners/and Lessees, as well as the Certificate of Surface Development prior to staff scheduling this request for public hearings.

PLN2: Applicant has provided a site plan that confirms that the leading edge of the sign pole will be setback equal to or greater than the height of the proposed billboard from the south property line; however, the applicant's site plan only provides a 40' setback from the north property line where a 50' setback is required.

- a. Applicant must revise their site plan in order to demonstrate that the required setbacks from both the south and north property lines will be met through this proposal.
- b. Alternatively, if the applicant is requesting a "Variation" from the setback requirement as part of this Conditional Use Permit request, they must provide a detailed explanation in order to justify why the required setbacks cannot be met and to describe any existing conditions on the site that have necessitated the placement of the proposed billboard in the chosen location.

PLN3: Applicant has provided a response that meets TCHD's requirements. This commitment will be memorialized as a proposed condition of approval.

---

**RCU2020-00014**

**Commenting Division:** Planning

**Resubmittal Required**

**Name of Reviewer:** Holden Pederson

**Email and Phone Number:** [HPederson@adcogov.org](mailto:HPederson@adcogov.org) / 720-523-6847

PLN1: Applicant must still provide the Certificate of Notice to Mineral Estate Owners/and Lessees, as well as the Certificate of Surface Development prior to staff scheduling this request for public hearings.

PLN2: The Title Report submitted by the applicant shows that there is a previous Conditional Use Permit approval for this site (RCU2019-00028) that expires on January 15, 2029. Applicant must describe why this second Conditional Use Permit approval is being requested and how this proposal differs from the separate approval that was recently granted in 2019.

PLN3: Applicant has provided a site plan that confirms that the leading edge of the sign pole will be setback equal to or greater than the height of the proposed billboard from all property lines.

PLN4: Applicant has provided a response that meets TCHD's requirements. This commitment will be memorialized as a proposed condition of approval.



**COLORADO**  
Department of  
Transportation

Region «Region» Traffic Section  
2829 West Howard Place  
«City», Colorado 80204  
Phone (303) 512-4272 Fax (303) 757-9886

July 14, 2020

Holden Pederson  
Planner II  
Community and Economic Development Department  
4430 South Adams County Parkway, Suite W200A  
Brighton, CO 80601-8216

**RE: Case Name: Street Media Washington Billboard CUP**  
**Case Number: RCU2020-00014**

Dear Mr. Pederson:

I have reviewed the referral for the CUP to allow an electronic billboard in the C-5 zone district, visible from I-270, located at 7190 N. Washington St., and have the following comments:

- This proposed digital billboard sign, which will advertise to Interstate 270, will require an Outdoor Advertising Permit from CDOT.
- This proposed sign must meet all Applicable rules governing outdoor advertising in Colorado per 2 CCR 601-3.
- Application packet, when completed, should be sent to Jacquelyn Jobe at 2829 W. Howard Place, 2<sup>nd</sup> Floor, Denver, CO 80204.

Thank you for the opportunity to review this referral.

Please feel free to contact me at the office listed above if I can of any further assistance in this or any other matter.

Sincerely,

Jacquelyn Jobe  
Region 1 Outdoor Advertising Representative  
(303) 512-4272



**From:** [Woodruff, Clayton](#)  
**To:** [Holden Pederson](#)  
**Subject:** RE Street Media Washington Billboard CUP  
**Date:** Tuesday, June 30, 2020 8:26:30 AM

---

Please be cautious: This email was sent from outside Adams County

Holden,

The RTD has no comment on this project.



**C. Scott Woodruff**  
**Engineer III**

Regional Transportation District  
1560 Broadway, Suite 700, FAS-73 | Denver, CO 80202

o 303.299.2943 | m 303-720-2025  
[clayton.woodruff@rd-denver.com](mailto:clayton.woodruff@rd-denver.com)



July 1, 2020

Holden Pederson  
Adams County Community and Economic Development  
4430 South Adams County Parkway, Suite W2000A  
Brighton, CO 80601

RE: StreetMedia Washington Billboard, RCU2020-00014  
TCHD Case No. 6345

Dear Mr. Pederson,

Thank you for the opportunity to review and comment on the Conditional Use Permit for an electronic billboard in the Commercial-5 (C-5) zone district located at 7190 N Washington Street. Tri-County Health Department (TCHD) staff has reviewed the application for compliance with applicable environmental and public health regulations and principles of healthy community design. After reviewing the application, TCHD has no comments.

Please feel free to contact me at 720-200-1585 or [ahenrich@tchd.org](mailto:ahenrich@tchd.org) if you have any questions.

Sincerely,

A handwritten signature in black ink that reads "AHF".

Annemarie Heinrich Fortune, MPH/MURP  
Land Use and Built Environment Specialist

cc: Sheila Lynch, Monte Deatrich, TCHD



Right of Way & Permits  
1123 West 3<sup>rd</sup> Avenue  
Denver, Colorado 80223  
Telephone: 303.571.3306  
Facsimile: 303.571.3284  
donna.l.george@xcelenergy.com

July 16, 2020

Adams County Community and Economic Development Department  
4430 South Adams County Parkway, 3<sup>rd</sup> Floor, Suite W3000  
Brighton, CO 80601

Attn: Holden Pederson

**Re: StreetMedia Washington Billboard, Case # RCU2020-00014**

Public Service Company of Colorado's (PSCo) Right of Way & Permits Referral Desk has reviewed the documentation for **StreetMedia Washington Billboard** and has **no apparent conflict**.

Please be aware PSCo owns and operates existing natural gas service facilities near the base of the proposed sign. As a safety precaution, PSCo would like to remind the developer to call the Utility Notification Center by dialing 811 for utility locates prior to construction. Use caution and hand dig when excavating within 18-inches of each side of the marked facilities. Please be aware that all risk and responsibility for this request are unilaterally that of the Applicant/Requestor.

Donna George  
Right of Way and Permits  
Public Service Company of Colorado dba Xcel Energy  
Office: 303-571-3306 – Email: donna.l.george@xcelenergy.com



## Request for Comments

Case Name: StreetMedia Washington Billboard CUP  
Case Number: RCU2020-00014

June 23, 2020

The Adams County Planning Commission is requesting comments on the following application: **Conditional Use Permit for an electronic billboard in the C-5 zone district visible from I-270.** This request is located at 7190 N WASHINGTON ST. The Assessor's Parcel Number is 0182502202021.

Applicant Information: STREET MEDIA GROUP LLC  
GARY YOUNG  
161 SATURN DRIVE  
FT. COLLINS, CO 80525

Please forward any written comments on this application to the Community and Economic Development Department at 4430 South Adams County Parkway, Suite W2000A Brighton, CO 80601-8216 or call (720) 523-6800 by **07/16/2020** in order that your comments may be taken into consideration in the review of this case. If you would like your comments included verbatim please send your response by way of e-mail to [HPederson@adcogov.org](mailto:HPederson@adcogov.org).

Once comments have been received and the staff report written, the staff report and notice of public hearing dates may be forwarded to you upon request. The full text of the proposed request and additional colored maps can be obtained by contacting this office or by accessing the Adams County web site at [www.adcogov.org/planning/currentcases](http://www.adcogov.org/planning/currentcases).

Thank you for your review of this case.

Holden Pederson  
Planner II





## Public Hearing Notification

Case Name:	StreetMedia 7154 Washington Billboard CUP
Case Number:	RCU2020-00014
Planning Commission Hearing Date:	01/28/2021 at 6:00 p.m.
Board of County Commissioners Hearing Date:	02/23/2021 at 9:30 a.m.

January 5, 2021

A public hearing has been set by the Adams County Planning Commission and the Board of County Commissioners to consider the following request:

**Conditional Use Permit for an electronic billboard in the C-5 zone district visible from I-270.**

The proposed use will be Commercial. This request is located at 7154 N WASHINGTON ST on undetermined parcel size.

The Assessor's Parcel Number(s) 0182502202021

Applicant Information: TROY HAMMOND  
Street Media Group LLC

This meeting is broadcast live on the Adams County YouTube channel. You can view the meeting live through the county YouTube Channel link: <https://www.youtube.com/channel/UC7KDbF1XykrY1xnfhEH5XVA/> and post comments on this agenda through the web at <https://adcogov.legistar.com/Calendar.aspx>

Members of the public may submit written comments on any matter within the Board's subject matter jurisdiction, post comments on this specific agenda item, or request to speak at the meeting through our eComment system at <https://adcogov.legistar.com/Calendar.aspx>

Residents are encouraged to submit comments, prior to the meeting, through written comment using eComment; eComment is integrated with the published meeting agenda and individuals may review the agenda item details and indicate their position on each item. A request to speak at the meeting may also be submitted using the eComment feature. You will be prompted to set up a user profile to allow you to comment, which will become part of the official public record. The eComment period opens when the agenda is published and closes at 4:30 p.m. the Monday prior to the noticed meeting.

BOARD OF COUNTY COMMISSIONERS

Eva J. Henry  
DISTRICT 1

Charles "Chaz" Tedesco  
DISTRICT 2

Emma Pinter  
DISTRICT 3

Steve O'Doriso  
DISTRICT 4

Mary Hodge  
DISTRICT 5

The full text of the proposed request and additional colored maps can be obtained by contacting this office or by accessing the Adams County web site at [www.adcogov.org/planning/currentcases](http://www.adcogov.org/planning/currentcases).

Thank you for your review of this case.

A handwritten signature in black ink, appearing to read "Holden Pederson". The signature is fluid and cursive, with the first name "Holden" and last name "Pederson" clearly distinguishable.

Holden Pederson  
Planner II

# PUBLICATION REQUEST

## StreetMedia 7154 Washington Billboard CUP

**Case Number:** RCU2020-00014  
**Planning Commission Hearing Date:** 01/28/2021 at 6:00 p.m.  
**Board of County Commissioners Hearing Date:** 02/23/2021 at 9:30 a.m.

**Request:** Conditional Use Permit for an electronic billboard in the C-5 zone district visible from I-270.

**Location:** 7154 N WASHINGTON ST  
**Parcel Number:** 0182502202021  
**Case Manager:** Holden Pederson  
**Case Technician:** Rayleen Swarts  
**Applicant:** TROY HAMMOND Street  
Media Group LLC  
**Owner:** CENTER LAND PROPERTIES  
7285 GILPIN WAY SUITE 100  
DENVER, CO 80229

**Representative:**

**Legal Description:** SUB:NORTH SIDE GARDENS DESC: PLOT 4 EXC RD

---

---

---

---



Referral Listing  
Case Number RCU2020-00014  
StreetMedia Washington Billboard CUP

Agency

Contact Information

ADAMS 12 FIVE STAR SCHOOLS

MATT SCHAEFER - PLANNING MANAGER  
1500 E. 128TH AVENUE  
THORNTON CO 80241  
720-972-4289  
matt.schaefer@adams12.org

Adams County Attorney's Office

Christine Fitch  
CFitch@adcogov.org  
4430 S Adams County Pkwy  
Brighton CO 80601  
720-523-6352

Adams County CEDD Development Services Engineer

Devt. Services Engineering  
4430 S. Adams County Pkwy.  
Brighton CO 80601  
720-523-6800

Adams County CEDD Environmental Services Division

Katie Keefe  
4430 S Adams County Pkwy  
Brighton CO 80601  
720-523-6986  
kkeefe@adcogov.org

Adams County CEDD Right-of-Way

Mark Alessi  
4430 S. Adams County Pkwy.  
Brighton CO 80601  
720-523-6837  
malessi@adcogov.org

Adams County Community Safety & Wellbeing, Neighborhood Services

Gail Moon  
gmoon@adcogov.org  
4430 S. Adams County Pkwy.  
Brighton CO 80601  
720-523-6856  
gmoon@adcogov.org

Adams County Development Services - Building

Justin Blair  
4430 S Adams County Pkwy  
Brighton CO 80601  
720-523-6825  
JBlair@adcogov.org

Adams County Fire Protection District

Chris Wilder  
8055 N. WASHINGTON ST.  
DENVER CO 80229  
(303) 289-4683  
cwilder@acfpd.org

AgencyContact Information

---

Adams County Parks and Open Space Department

Aaron Clark  
(303) 637-8005  
aclark@adcogov.org

Adams County Parks and Open Space Department

Marc Pedrucci  
303-637-8014  
mpedrucci@adcogov.org

ADAMS COUNTY SCHOOL DISTRICT 14

Leo Rodriguez  
5291 E. 60th Avenue  
COMMERCE CITY CO 80022  
303.853.3217  
lrodriguez@adams14.org

Adams County Sheriff's Office: SO-HQ

Rick Reigenborn  
(303) 654-1850  
rreigenborn@adcogov.org

Adams County Sheriff's Office: SO-SUB

- -  
303-655-3283  
CommunityConnections@adcogov.org

CDOT Colorado Department of Transportation

Bradley Sheehan  
2829 W. Howard Pl.  
2nd Floor  
Denver CO 80204  
303.757.9891  
bradley.sheehan@state.co.us

CDPHE

Sean Hackett  
4300 S Cherry Creek Dr  
Denver CO 80246  
303.692.3662 303.691.7702  
cdphe\_localreferral@state.co.us

CDPHE

Sean Hackett  
4300 S Cherry Creek Dr  
Denver CO 80246  
30  
sean.hackett@state.co.us

CDPHE - AIR QUALITY

Richard Coffin  
4300 CHERRY CREEK DRIVE SOUTH  
DENVER CO 80246-1530  
303.692.3127  
richard.coffin@state.co.us

CDPHE - WATER QUALITY PROTECTION SECT

Patrick Pfaltzgraff  
4300 CHERRY CREEK DRIVE SOUTH  
WQCD-B2  
DENVER CO 80246-1530  
303-692-3509  
patrick.j.pfaltzgraff@state.co.us

CDPHE SOLID WASTE UNIT

Andy Todd  
4300 CHERRY CREEK DR SOUTH  
HMWMD-CP-B2  
DENVER CO 80246-1530  
303.691.4049  
Andrew.Todd@state.co.us

Agency

Contact Information

---

Century Link, Inc

Brandyn Wiedreich  
5325 Zuni St, Rm 728  
Denver CO 80221  
720-578-3724 720-245-0029  
brandyn.wiedrich@centurylink.com

CITY OF FEDERAL HEIGHTS

Renae Stavros  
2380 W. 90th Ave.  
Federal Heights CO 80260  
303.412.3530  
rstavros@fedheights.org

CITY OF FEDERAL HEIGHTS

TIM WILLIAMS  
2380 W 90TH AVE.  
FEDERAL HEIGHTS CO 80260  
303-428-3526  
twilliams@fedheights.org

CITY OF FEDERAL HEIGHTS - WATER AND SAN. DEPT.

VIRGINIA MULLIN  
2380 W 90TH AVE.  
FEDERAL HEIGHTS CO 80260  
303-428-3526

CITY OF THORNTON

JASON O'SHEA  
9500 CIVIC CENTER DR  
THORNTON CO 80229  
0

CITY OF THORNTON

Lori Hight  
9500 CIVIC CENTER DRIVE  
THORNTON CO 80229  
303-538-7670  
developmentsubmittals@cityofthornton.net.

CITY OF THORNTON

JIM KAISER  
12450 N WASHINGTON  
THORNTON CO 80241  
720-977-6266

COLORADO DEPT OF TRANSPORTATION

Steve Loeffler  
2000 S. Holly St.  
Region 1  
Denver CO 80222  
303-757-9891  
steven.loeffler@state.co.us

COLORADO DIVISION OF WILDLIFE

Serena Rocksund  
6060 BROADWAY  
DENVER CO 80216  
3039471798  
serena.rocksund@state.co.us

COLORADO DIVISION OF WILDLIFE

Matt Martinez  
6060 BROADWAY  
DENVER CO 80216-1000  
303-291-7526  
matt.martinez@state.co.us

Agency

Contact Information

---

COMCAST

JOE LOWE  
8490 N UMITILLA ST  
FEDERAL HEIGHTS CO 80260  
303-603-5039  
thomas\_lowe@cable.comcast.com

Commerce City Planning Division

Domenic Martinelli  
7887 East 60th Avenue  
COMMERCE CITY CO 80022  
303-289-3693  
dmartinelli@c3gov.com

Crestview Water & Sanitation

Patrick Stock  
7145 Mariposa St  
PO Box 21299  
Denver CO 80221-0299  
303-430-1660 303-434-0607  
PatrickStock@crestviewwater.net

FEDERAL HEIGHTS FIRE DEPT.

ANDREW MARSH  
2400 W. 90TH AVE.  
FEDERAL HEIGHTS CO 80260  
303-428-3526 x 260

MAPLETON SCHOOL DISTRICT #1

CHARLOTTE CIANCIO  
591 E. 80TH AVE  
DENVER CO 80229  
303-853-1015  
charlotte@mapleton.us

METRO WASTEWATER RECLAMATION

CRAIG SIMMONDS  
6450 YORK ST.  
DENVER CO 80229  
303-286-3338  
CSIMMONDS@MWRD.DST.CO.US

North Pecos Water & Sanitation District

Russell Traska  
6900 Pecos St  
Denver CO 80221  
303-429-5770  
manager@northpecoswater.org

North Washington Street Water & San Dist

Joe Jamsay  
3172 E 78th Ave  
Denver CO 80229  
303-288-6664  
jjames@nswsd.com

NS - Code Compliance

Kerry Gress  
kgress@adcogov.org  
720.523.6832  
kgress@adcogov.org

NS - Code Compliance

Gail Moon  
gmoon@adcogov.org  
720.523.6833  
gmoon@adcogov.org

Agency

Contact Information

---

NS - Code Compliance

Caleb Bachelor  
4430 S. Adams County Pkwy  
Brighton CO 80601  
720.523.6206  
cbachelor@adcogov.org

NS - Code Compliance

Joaquin Flores  
720.523.6207  
jflores@adcogov.org

PERL MACK NEIGHBORHOOD GROUP

DAN MICEK - PRESIDENT  
7294 NAVAJO ST.  
DENVER CO 80221  
303-428-8557  
DANMICEK54@COMCAST.NET

REGIONAL TRANSPORTATION DIST.

Engineering RTD  
1560 BROADWAY SUITE 700  
DENVER CO 80202  
303-299-2439  
engineering@rtd-denver.com

SOUTH ADAMS CO. FIRE DISTRICT

Randall Weigum  
6050 Syracuse Street  
COMMERCE CITY CO 80022  
720-573-9790 FAX: 303-288-5977  
rweigum@sacfd.org

SOUTH ADAMS CO. FIRE DISTRICT

- Fire Prevention Division  
6050 Syracuse Street  
Commerce City CO 80022  
303-288-0835  
planreview@sacfd.org

South Adams County Water & San Dist

Abel Moreno  
10200 E 102nd Ave  
Henderson CO 80022  
720-206-0590  
amoreno@sacwsd.org

THORNTON FIRE DEPARTMENT

Chad Mccollum  
9500 Civic Center Drive  
THORNTON CO 80229-4326  
303-538-7602  
firedept@cityofthornton.net

UNION PACIFIC RAILROAD

Anna Dancer  
1400 DOUGLAS ST STOP 1690  
OMAHA NE 68179  
402-544-2255  
aldancer@up.com

WELBY CITIZEN GROUP

NORMA FRANK  
7401 RACE STREET  
DENVER CO 80229  
(303) 288-3152



Agency

Contact Information

---

WESTMINSTER SCHOOL DISTRICT #50

Jackie Peterson  
7002 Raleigh Street  
WESTMINSTER CO 80030  
720-542-5100  
jpeterson@adams50.org

Xcel Energy

Donna George  
1123 W 3rd Ave  
DENVER CO 80223  
303-571-3306  
Donna.L.George@xcelenergy.com

Xcel Energy

Donna George  
1123 W 3rd Ave  
DENVER CO 80223  
303-571-3306  
Donna.L.George@xcelenergy.com

1000 EAST 73RD AVENUE  
4565 AUHAY DR  
SANTA BARBARA CA 93110-1705

CENTER PLAZA LLC  
1480 E 73RD AVE  
DENVER CO 80229-6902

851 E HWY 224 LLC  
1420 BELLAIRE ST  
DENVER CO 80220-2413

CENTRAL CONNECTION LLC  
1855 S PEARL ST STE 20  
DENVER CO 80210-3181

851224 LLC  
5040 ACOMA ST  
DENVER CO 80216-2010

CENTRAL CONNECTION LLC  
1855 S PEARL ST STE 20  
DENVER CO 80210-3181

A & B PROPERTY LLC  
851 E COLORADO HIGHWAY 224 UNIT A5  
DENVER CO 80229-6854

CHAPMAN JERROD SCOTT  
1613 E 164TH PL  
BRIGHTON CO 80602-7664

A AND R LLC  
7754 PARFET ST  
ARVADA CO 80005

CHESROWN COLLISION CENTER INC  
7420 N WASHINGTON STREET  
DENVER CO 80229

ABP INVESTMENTS LLC  
1620 W 74TH WAY  
DENVER CO 80221-3401

CITY OF THORNTON THE  
9500 CIVIC CENTER DR  
DENVER CO 80229-4326

BARRANDEY IRENE ACOSTA AND  
RODRIGUEZ OCTAVIO TORRES  
1437 S WOLCOTT WAY  
DENVER CO 80219-3615

COLORADO DEPARTMENT OF  
TRANSPORTATION  
2000 SOUTH HOLLY ST  
DENVER CO 80222-4818

BURKEY MANAGEMENT COMPANY  
12021 PENNSYLVANIA ST STE 102  
THORNTON CO 80241-3151

CONDON MICHAEL L  
8681 ROSEMARY ST  
COMMERCE CITY CO 80022-5052

CARJO L L C  
213 GRAND VIEW CIR  
MEAD CO 80542-9001

DEPARTMENT OF TRANSPORTATION  
2829 W HOWARD PL  
DENVER CO 80204-2305

CENTER LAND PROPERTIES  
7285 GILPIN WAY SUITE 100  
DENVER CO 80229

DOMENICO CAROLYN  
3558 W 111TH DR UNIT A  
WESTMINSTER CO 80031

DOMENICO CAROLYN M  
3558 WEST 111TH DRIVE NO. A  
WESTMINSTER CO 80031-6851

KRIEGER ELIZABETH ANN AND JIULIANO  
ELIZABETH ANN AND JIULIANO JOSEPH NICK J  
7095 N WASHINGTON ST  
DENVER CO 80229-6703

GACCETTA BERNICE REVOCABLE LIVING TRUST  
GACCETTA FRANK REVOCABLE LIVING TRUST  
5247 EAGLE MEADOW DR  
DACONO CO 80514-8539

LEVIN GARY  
4565 AUHAY DR  
SANTA BARBARA CA 93110-1705

GACCETTA DANNY AND  
GACCETTA BRIANNA  
13252 ELIZABETH ST  
THORNTON CO 80241-2063

MADRID JORGE CURIEL  
4075 W 51ST AVE  
DENVER CO 80212-2657

HACK CHRISTOPHER LEE  
11755 AIRPORT WAY STE 149  
BROOMFIELD CO 80021-2502

MARLYNC LLC  
16670 JASMINE ST  
BRIGHTON CO 80602-6053

HALEIGH S HOPE INC  
6525 GUNPARK DR STE 370-236  
BOULDER CO 80301-3346

MAURER SCOTT AND  
MAURER KIMBERLEY W  
9114 E 29TH PL  
DENVER CO 80238-2718

HEGGE JOEL AND  
HEGGE KAREN  
13320 CHERRY CIR  
THORNTON CO 80241-1528

MC DANIEL LARRY E AND NANCY J  
3105 MEGAN WAY  
BERTHOUD CO 80513-8078

HIGH NOON ASSOCIATES  
4565 AUHAY DR  
SANTA BARBARA CA 93110-1705

NLT LLC  
891 E 71ST AVE  
DENVER CO 80229-6806

HIRED HAND DENVER LLC  
2 DALEWOOD TER  
ORINDA CA 94563-1224

PETERSON DONALD O  
12055 WELD CO RD NO. 2  
BRIGHTON CO 80601

JOHNSTON CHARLES S  
PO BOX 341  
BRIGHTON CO 80601

PRIMA CAR CARE LLC  
6660 FERN DR  
DENVER CO 80221-2645

K L WERTH LLC  
2555 E 70TH AVENUE  
DENVER CO 80229

R MOORE PROPERTIES LLC  
2721 E 138TH PL  
THORNTON CO 80602-7226

RENERIA ROSENDO VETANCOURTH AND  
RENERIA NICOLAS BETANCOURT  
355 JULIAN ST  
DENVER CO 80219-1435

BURTON KAY A  
OR CURRENT RESIDENT  
1161 E 73RD AVE  
DENVER CO 80229-6851

RYAN FAMILY LLC  
1075 W 140TH DR  
WESTMINSTER CO 80023-9351

NLT LLC  
OR CURRENT RESIDENT  
891 E 71ST AVE  
DENVER CO 80229-6806

STATE HIGHWAY DEPT  
2000 S HOLLY ST  
DENVER CO 80222-4818

SAYLOR JAMES M AND  
SAYLOR HARRY M  
OR CURRENT RESIDENT  
940 E 73RD AVE  
DENVER CO 80229-6817

TMA PROPERTIES LLC  
6725 W 97TH PL  
BROOMFIELD CO 80021-5404

VIVA A&R LLC  
OR CURRENT RESIDENT  
1040 E 71ST AVE  
DENVER CO 80229-6810

TRUSTILE DOORS LLC  
1780 E 66TH AVE  
DENVER CO 80229

CURRENT RESIDENT  
7314 WASHINGTON ST  
DENVER CO 80229-6302

WASHINGTON COMMERCE CENTER LLC  
C/O COMPTON DANDO, INC  
DENVER CO 80239-3454

CURRENT RESIDENT  
7316 WASHINGTON ST  
DENVER CO 80229-6302

WASHINGTON GARDENS BPT LLC UND 50% AND  
WASHINGTON GARDENS RANDALL LLC UND 50%  
C/O COMPTON DANDO INC  
DENVER CO 80239-3454

CURRENT RESIDENT  
7318 WASHINGTON ST  
DENVER CO 80229-6302

WERSHAW ROBERT L AND  
WERSHAW ESTHER B  
1566 WINONA CT  
DENVER CO 80204-1143

CURRENT RESIDENT  
7330 WASHINGTON ST  
DENVER CO 80229-6302

7295 HOLDING COMPANY LLC  
C/O LUNA GOURMET COFFEE AND TEA CO LLC  
OR CURRENT RESIDENT  
7295 WASHINGTON ST  
DENVER CO 80229-6707

CURRENT RESIDENT  
7334 WASHINGTON ST  
DENVER CO 80229-6302

A&B PROPERTY LLC  
OR CURRENT RESIDENT  
851 E HIGHWAY 224 UNIT A5  
DENVER CO 80229-6853

CURRENT RESIDENT  
7338 WASHINGTON ST  
DENVER CO 80229-6302

CURRENT RESIDENT  
7346 WASHINGTON ST  
DENVER CO 80229-6302

CURRENT RESIDENT  
525 E 70TH AVE UNIT 1E  
DENVER CO 80229-6712

CURRENT RESIDENT  
7348 WASHINGTON ST  
DENVER CO 80229-6302

CURRENT RESIDENT  
525 E 70TH AVE UNIT 1W  
DENVER CO 80229-6712

CURRENT RESIDENT  
7352 WASHINGTON ST  
DENVER CO 80229-6302

CURRENT RESIDENT  
525 E 70TH AVE UNIT 2E  
DENVER CO 80229-6712

CURRENT RESIDENT  
7354 WASHINGTON ST  
DENVER CO 80229-6302

CURRENT RESIDENT  
525 E 70TH AVE UNIT 2W  
DENVER CO 80229-6712

CURRENT RESIDENT  
7420 WASHINGTON ST  
DENVER CO 80229-6304

CURRENT RESIDENT  
525 E 70TH AVE UNIT 3E  
DENVER CO 80229-6712

CURRENT RESIDENT  
7091 WASHINGTON ST  
DENVER CO 80229-6703

CURRENT RESIDENT  
525 E 70TH AVE UNIT 3W  
DENVER CO 80229-6712

CURRENT RESIDENT  
7095 WASHINGTON ST  
DENVER CO 80229-6703

CURRENT RESIDENT  
565 E 70TH AVE UNIT 1E  
DENVER CO 80229-6713

CURRENT RESIDENT  
7150 WASHINGTON ST  
DENVER CO 80229-6706

CURRENT RESIDENT  
565 E 70TH AVE UNIT 1W  
DENVER CO 80229-6713

CURRENT RESIDENT  
7154 WASHINGTON ST  
DENVER CO 80229-6706

CURRENT RESIDENT  
565 E 70TH AVE UNIT 2E  
DENVER CO 80229-6713

CURRENT RESIDENT  
7261 WASHINGTON ST  
DENVER CO 80229-6707

CURRENT RESIDENT  
565 E 70TH AVE UNIT 2W  
DENVER CO 80229-6713

CURRENT RESIDENT  
565 E 70TH AVE UNIT 3E  
DENVER CO 80229-6713

CURRENT RESIDENT  
565 E 70TH AVE UNIT 8E  
DENVER CO 80229-6713

CURRENT RESIDENT  
565 E 70TH AVE UNIT 3W  
DENVER CO 80229-6713

CURRENT RESIDENT  
565 E 70TH AVE UNIT 8W  
DENVER CO 80229-6713

CURRENT RESIDENT  
565 E 70TH AVE UNIT 4E  
DENVER CO 80229-6713

CURRENT RESIDENT  
605 E 70TH AVE UNIT 1  
DENVER CO 80229-6714

CURRENT RESIDENT  
565 E 70TH AVE UNIT 4W  
DENVER CO 80229-6713

CURRENT RESIDENT  
605 E 70TH AVE UNIT 2  
DENVER CO 80229-6714

CURRENT RESIDENT  
565 E 70TH AVE UNIT 5E  
DENVER CO 80229-6713

CURRENT RESIDENT  
605 E 70TH AVE UNIT 3  
DENVER CO 80229-6714

CURRENT RESIDENT  
565 E 70TH AVE UNIT 5W  
DENVER CO 80229-6713

CURRENT RESIDENT  
605 E 70TH AVE UNIT 4  
DENVER CO 80229-6714

CURRENT RESIDENT  
565 E 70TH AVE UNIT 6E  
DENVER CO 80229-6713

CURRENT RESIDENT  
605 E 70TH AVE UNIT 5  
DENVER CO 80229-6714

CURRENT RESIDENT  
565 E 70TH AVE UNIT 6W  
DENVER CO 80229-6713

CURRENT RESIDENT  
605 E 70TH AVE UNIT 6  
DENVER CO 80229-6714

CURRENT RESIDENT  
565 E 70TH AVE UNIT 7E  
DENVER CO 80229-6713

CURRENT RESIDENT  
605 E 70TH AVE UNIT 7  
DENVER CO 80229-6714

CURRENT RESIDENT  
565 E 70TH AVE UNIT 7W  
DENVER CO 80229-6713

CURRENT RESIDENT  
605 E 70TH AVE UNIT 8  
DENVER CO 80229-6714

CURRENT RESIDENT  
625 E 70TH AVE UNIT 1  
DENVER CO 80229-6726

CURRENT RESIDENT  
665 E 70TH AVE UNIT 4  
DENVER CO 80229-6727

CURRENT RESIDENT  
625 E 70TH AVE UNIT 2  
DENVER CO 80229-6726

CURRENT RESIDENT  
665 E 70TH AVE UNIT 5  
DENVER CO 80229-6727

CURRENT RESIDENT  
625 E 70TH AVE UNIT 3  
DENVER CO 80229-6726

CURRENT RESIDENT  
665 E 70TH AVE UNIT 6  
DENVER CO 80229-6727

CURRENT RESIDENT  
625 E 70TH AVE UNIT 4  
DENVER CO 80229-6726

CURRENT RESIDENT  
7174 WASHINGTON ST STE A  
DENVER CO 80229-6731

CURRENT RESIDENT  
625 E 70TH AVE UNIT 5  
DENVER CO 80229-6726

CURRENT RESIDENT  
7174 WASHINGTON ST STE B  
DENVER CO 80229-6731

CURRENT RESIDENT  
625 E 70TH AVE UNIT 6  
DENVER CO 80229-6726

CURRENT RESIDENT  
7174 WASHINGTON ST STE C  
DENVER CO 80229-6731

CURRENT RESIDENT  
665 E 70TH AVE UNIT 1  
DENVER CO 80229-6727

CURRENT RESIDENT  
750 E 71ST AVE UNIT A  
DENVER CO 80229-6800

CURRENT RESIDENT  
665 E 70TH AVE UNIT 2  
DENVER CO 80229-6727

CURRENT RESIDENT  
750 E 71ST AVE UNIT B  
DENVER CO 80229-6800

CURRENT RESIDENT  
665 E 70TH AVE UNIT 2B  
DENVER CO 80229-6727

CURRENT RESIDENT  
750 E 71ST AVE UNIT C  
DENVER CO 80229-6800

CURRENT RESIDENT  
665 E 70TH AVE UNIT 3  
DENVER CO 80229-6727

CURRENT RESIDENT  
750 E 71ST AVE UNIT D  
DENVER CO 80229-6800

CURRENT RESIDENT  
750 E 71ST AVE UNIT E  
DENVER CO 80229-6800

CURRENT RESIDENT  
981 E HIGHWAY 224 UNIT G  
DENVER CO 80229-6811

CURRENT RESIDENT  
1015 E 70TH AVE  
DENVER CO 80229-6803

CURRENT RESIDENT  
981 E HIGHWAY 224 UNIT H  
DENVER CO 80229-6811

CURRENT RESIDENT  
1041 E 70TH AVE  
DENVER CO 80229-6803

CURRENT RESIDENT  
981 E HIGHWAY 224 UNIT I  
DENVER CO 80229-6811

CURRENT RESIDENT  
1061 E 70TH AVE  
DENVER CO 80229-6803

CURRENT RESIDENT  
981 E HIGHWAY 224 UNIT J  
DENVER CO 80229-6811

CURRENT RESIDENT  
800 E 71ST AVE  
DENVER CO 80229-6808

CURRENT RESIDENT  
981 E HIGHWAY 224 UNIT K  
DENVER CO 80229-6811

CURRENT RESIDENT  
1020 E 71ST AVE  
DENVER CO 80229-6810

CURRENT RESIDENT  
981 E HIGHWAY 224 UNIT L  
DENVER CO 80229-6811

CURRENT RESIDENT  
981 E HIGHWAY 224 UNIT B  
DENVER CO 80229-6811

CURRENT RESIDENT  
981 E HIGHWAY 224 UNIT M  
DENVER CO 80229-6811

CURRENT RESIDENT  
981 E HIGHWAY 224 UNIT C  
DENVER CO 80229-6811

CURRENT RESIDENT  
981 E HIGHWAY 224 UNIT N  
DENVER CO 80229-6811

CURRENT RESIDENT  
981 E HIGHWAY 224 UNIT D  
DENVER CO 80229-6811

CURRENT RESIDENT  
981 E HIGHWAY 224 UNIT O  
DENVER CO 80229-6811

CURRENT RESIDENT  
981 E HIGHWAY 224 UNIT F  
DENVER CO 80229-6811

CURRENT RESIDENT  
981 E HIGHWAY 224 UNIT P  
DENVER CO 80229-6811



CURRENT RESIDENT  
1100 E 73RD AVE UNIT A  
DENVER CO 80229-6812

CURRENT RESIDENT  
1100 E 73RD AVE UNIT K  
DENVER CO 80229-6812

CURRENT RESIDENT  
1100 E 73RD AVE UNIT B  
DENVER CO 80229-6812

CURRENT RESIDENT  
1100 E 73RD AVE UNIT L  
DENVER CO 80229-6812

CURRENT RESIDENT  
1100 E 73RD AVE UNIT C  
DENVER CO 80229-6812

CURRENT RESIDENT  
821 E 73RD AVE  
DENVER CO 80229-6815

CURRENT RESIDENT  
1100 E 73RD AVE UNIT D  
DENVER CO 80229-6812

CURRENT RESIDENT  
825 E 73RD AVE  
DENVER CO 80229-6815

CURRENT RESIDENT  
1100 E 73RD AVE UNIT E  
DENVER CO 80229-6812

CURRENT RESIDENT  
831 E 73RD AVE  
DENVER CO 80229-6815

CURRENT RESIDENT  
1100 E 73RD AVE UNIT F  
DENVER CO 80229-6812

CURRENT RESIDENT  
835 E 73RD AVE  
DENVER CO 80229-6815

CURRENT RESIDENT  
1100 E 73RD AVE UNIT G  
DENVER CO 80229-6812

CURRENT RESIDENT  
841 E 73RD AVE  
DENVER CO 80229-6815

CURRENT RESIDENT  
1100 E 73RD AVE UNIT H  
DENVER CO 80229-6812

CURRENT RESIDENT  
845 E 73RD AVE  
DENVER CO 80229-6815

CURRENT RESIDENT  
1100 E 73RD AVE UNIT I  
DENVER CO 80229-6812

CURRENT RESIDENT  
851 E 73RD AVE  
DENVER CO 80229-6815

CURRENT RESIDENT  
1100 E 73RD AVE UNIT J  
DENVER CO 80229-6812

CURRENT RESIDENT  
853 E 73RD AVE  
DENVER CO 80229-6815

CURRENT RESIDENT  
855 E 73RD AVE  
DENVER CO 80229-6815

CURRENT RESIDENT  
1210 E 73RD AVE  
DENVER CO 80229-6821

CURRENT RESIDENT  
859 E 73RD AVE  
DENVER CO 80229-6815

CURRENT RESIDENT  
851 E HIGHWAY 224 UNIT A11  
DENVER CO 80229-6829

CURRENT RESIDENT  
861 E 73RD AVE  
DENVER CO 80229-6815

CURRENT RESIDENT  
851 E HIGHWAY 224 UNIT A1  
DENVER CO 80229-6853

CURRENT RESIDENT  
863 E 73RD AVE  
DENVER CO 80229-6815

CURRENT RESIDENT  
851 E HIGHWAY 224 UNIT A10  
DENVER CO 80229-6853

CURRENT RESIDENT  
865 E 73RD AVE  
DENVER CO 80229-6815

CURRENT RESIDENT  
851 E HIGHWAY 224 UNIT A2  
DENVER CO 80229-6853

CURRENT RESIDENT  
881 E 73RD AVE  
DENVER CO 80229-6815

CURRENT RESIDENT  
851 E HIGHWAY 224 UNIT A3  
DENVER CO 80229-6853

CURRENT RESIDENT  
901 E 73RD AVE  
DENVER CO 80229-6816

CURRENT RESIDENT  
851 E HIGHWAY 224 UNIT A4  
DENVER CO 80229-6853

CURRENT RESIDENT  
983 E 73RD AVE  
DENVER CO 80229-6816

CURRENT RESIDENT  
851 E HIGHWAY 224 UNIT A6  
DENVER CO 80229-6853

CURRENT RESIDENT  
950 E 73RD AVE  
DENVER CO 80229-6817

CURRENT RESIDENT  
851 E HIGHWAY 224 UNIT A7  
DENVER CO 80229-6853

CURRENT RESIDENT  
1051 E 73RD AVE  
DENVER CO 80229-6818

CURRENT RESIDENT  
851 E HIGHWAY 224 UNIT A8  
DENVER CO 80229-6853

CURRENT RESIDENT  
851 E HIGHWAY 224 UNIT A9  
DENVER CO 80229-6853

CURRENT RESIDENT  
851 E HIGHWAY 224 UNIT B9  
DENVER CO 80229-6854

CURRENT RESIDENT  
851 E HIGHWAY 224 UNIT B1  
DENVER CO 80229-6854

CURRENT RESIDENT  
800 E 73RD AVE UNIT 1  
DENVER CO 80229-6855

CURRENT RESIDENT  
851 E HIGHWAY 224 UNIT B10  
DENVER CO 80229-6854

CURRENT RESIDENT  
800 E 73RD AVE UNIT 10  
DENVER CO 80229-6855

CURRENT RESIDENT  
851 E HIGHWAY 224 UNIT B2  
DENVER CO 80229-6854

CURRENT RESIDENT  
800 E 73RD AVE UNIT 11  
DENVER CO 80229-6855

CURRENT RESIDENT  
851 E HIGHWAY 224 UNIT B3  
DENVER CO 80229-6854

CURRENT RESIDENT  
800 E 73RD AVE UNIT 12  
DENVER CO 80229-6855

CURRENT RESIDENT  
851 E HIGHWAY 224 UNIT B4  
DENVER CO 80229-6854

CURRENT RESIDENT  
800 E 73RD AVE UNIT 13  
DENVER CO 80229-6855

CURRENT RESIDENT  
851 E HIGHWAY 224 UNIT B5  
DENVER CO 80229-6854

CURRENT RESIDENT  
800 E 73RD AVE UNIT 14  
DENVER CO 80229-6855

CURRENT RESIDENT  
851 E HIGHWAY 224 UNIT B6  
DENVER CO 80229-6854

CURRENT RESIDENT  
800 E 73RD AVE UNIT 15  
DENVER CO 80229-6855

CURRENT RESIDENT  
851 E HIGHWAY 224 UNIT B7  
DENVER CO 80229-6854

CURRENT RESIDENT  
800 E 73RD AVE UNIT 16  
DENVER CO 80229-6855

CURRENT RESIDENT  
851 E HIGHWAY 224 UNIT B8  
DENVER CO 80229-6854

CURRENT RESIDENT  
800 E 73RD AVE UNIT 17  
DENVER CO 80229-6855

CURRENT RESIDENT  
800 E 73RD AVE UNIT 18  
DENVER CO 80229-6855

CURRENT RESIDENT  
800 E 73RD AVE UNIT 7  
DENVER CO 80229-6855

CURRENT RESIDENT  
800 E 73RD AVE UNIT 19  
DENVER CO 80229-6855

CURRENT RESIDENT  
800 E 73RD AVE UNIT 8  
DENVER CO 80229-6855

CURRENT RESIDENT  
800 E 73RD AVE UNIT 2  
DENVER CO 80229-6855

CURRENT RESIDENT  
800 E 73RD AVE UNIT 9  
DENVER CO 80229-6855

CURRENT RESIDENT  
800 E 73RD AVE UNIT 20  
DENVER CO 80229-6855

CURRENT RESIDENT  
850 E 73RD AVE UNIT 1  
DENVER CO 80229-6856

CURRENT RESIDENT  
800 E 73RD AVE UNIT 21  
DENVER CO 80229-6855

CURRENT RESIDENT  
850 E 73RD AVE UNIT 10  
DENVER CO 80229-6856

CURRENT RESIDENT  
800 E 73RD AVE UNIT 25  
DENVER CO 80229-6855

CURRENT RESIDENT  
850 E 73RD AVE UNIT 12  
DENVER CO 80229-6856

CURRENT RESIDENT  
800 E 73RD AVE UNIT 3  
DENVER CO 80229-6855

CURRENT RESIDENT  
850 E 73RD AVE UNIT 2  
DENVER CO 80229-6856

CURRENT RESIDENT  
800 E 73RD AVE UNIT 4  
DENVER CO 80229-6855

CURRENT RESIDENT  
850 E 73RD AVE UNIT 3  
DENVER CO 80229-6856

CURRENT RESIDENT  
800 E 73RD AVE UNIT 5  
DENVER CO 80229-6855

CURRENT RESIDENT  
850 E 73RD AVE UNIT 4  
DENVER CO 80229-6856

CURRENT RESIDENT  
800 E 73RD AVE UNIT 6  
DENVER CO 80229-6855

CURRENT RESIDENT  
850 E 73RD AVE UNIT 5  
DENVER CO 80229-6856

CURRENT RESIDENT  
850 E 73RD AVE UNIT 6  
DENVER CO 80229-6856

CURRENT RESIDENT  
1000 E 73RD AVE UNIT 14  
DENVER CO 80229-6860

CURRENT RESIDENT  
850 E 73RD AVE UNIT 7  
DENVER CO 80229-6856

CURRENT RESIDENT  
1000 E 73RD AVE UNIT 15  
DENVER CO 80229-6860

CURRENT RESIDENT  
850 E 73RD AVE UNIT 8  
DENVER CO 80229-6856

CURRENT RESIDENT  
1000 E 73RD AVE UNIT 16  
DENVER CO 80229-6860

CURRENT RESIDENT  
850 E 73RD AVE UNIT 9  
DENVER CO 80229-6856

CURRENT RESIDENT  
1000 E 73RD AVE UNIT 2  
DENVER CO 80229-6860

CURRENT RESIDENT  
981 E HIGHWAY 224 UNIT A  
DENVER CO 80229-6858

CURRENT RESIDENT  
1000 E 73RD AVE UNIT 3  
DENVER CO 80229-6860

CURRENT RESIDENT  
1000 E 73RD AVE UNIT 1  
DENVER CO 80229-6860

CURRENT RESIDENT  
1000 E 73RD AVE UNIT 4  
DENVER CO 80229-6860

CURRENT RESIDENT  
1000 E 73RD AVE UNIT 10  
DENVER CO 80229-6860

CURRENT RESIDENT  
1000 E 73RD AVE UNIT 5  
DENVER CO 80229-6860

CURRENT RESIDENT  
1000 E 73RD AVE UNIT 11  
DENVER CO 80229-6860

CURRENT RESIDENT  
1000 E 73RD AVE UNIT 6  
DENVER CO 80229-6860

CURRENT RESIDENT  
1000 E 73RD AVE UNIT 12  
DENVER CO 80229-6860

CURRENT RESIDENT  
1000 E 73RD AVE UNIT 7  
DENVER CO 80229-6860

CURRENT RESIDENT  
1000 E 73RD AVE UNIT 13  
DENVER CO 80229-6860

CURRENT RESIDENT  
1000 E 73RD AVE UNIT 8  
DENVER CO 80229-6860

CURRENT RESIDENT  
1000 E 73RD AVE UNIT 9  
DENVER CO 80229-6860

CURRENT RESIDENT  
981 E HIGHWAY 224 UNIT E  
DENVER CO 80229-6861

CURRENT RESIDENT  
850 E 73RD AVE UNIT 11  
DENVER CO 80229-6862

# CERTIFICATE OF POSTING



I, **Holden Pederson**, do hereby certify that I had the property posted at

7154 Washington Street

on January 13, 2021

in accordance with the requirements of the Adams County Zoning Regulations

---

**Holden Pederson**

# **StreetMedia 7154 Washington Billboard CUP**

RCU2020-00014

7154 Washington Street

February 23, 2021

Board of County Commissioners Public Hearing  
Community and Economic Development Department

Case Manager: Holden Pederson





# Request

Conditional Use Permit to allow an off-premise electronic sign (billboard) in the Commercial-5 (C-5) zone district.

A previous Conditional Use Permit approval was granted for the same use on this site but has since expired (RCU2018-00028).

# Aerial View

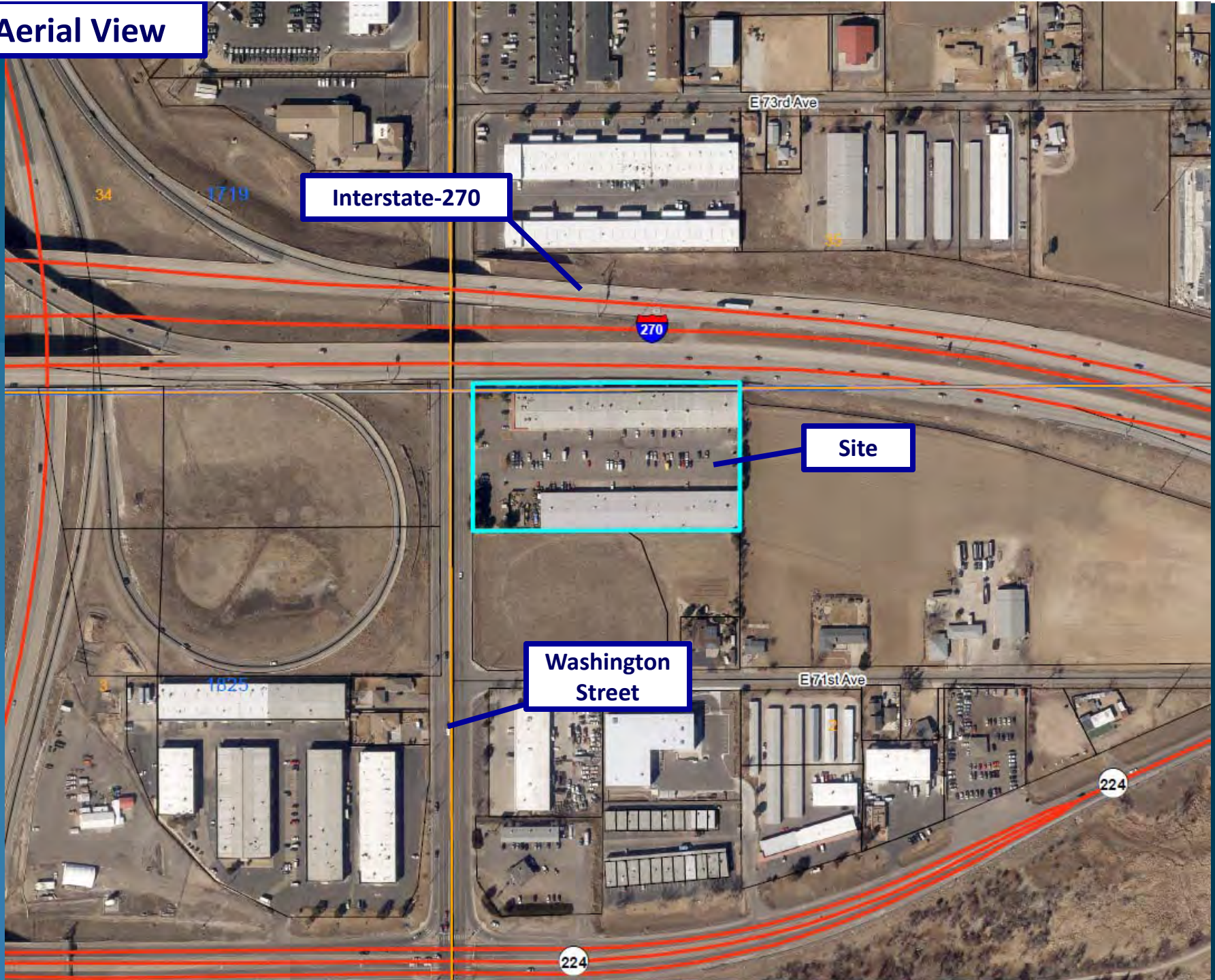

Interstate-270

Site

Washington Street

E73rd Ave

E71st Ave

224

224

34

1719

1825

# Aerial View

Interstate-270

Washington St

Proposed  
Billboard  
Location

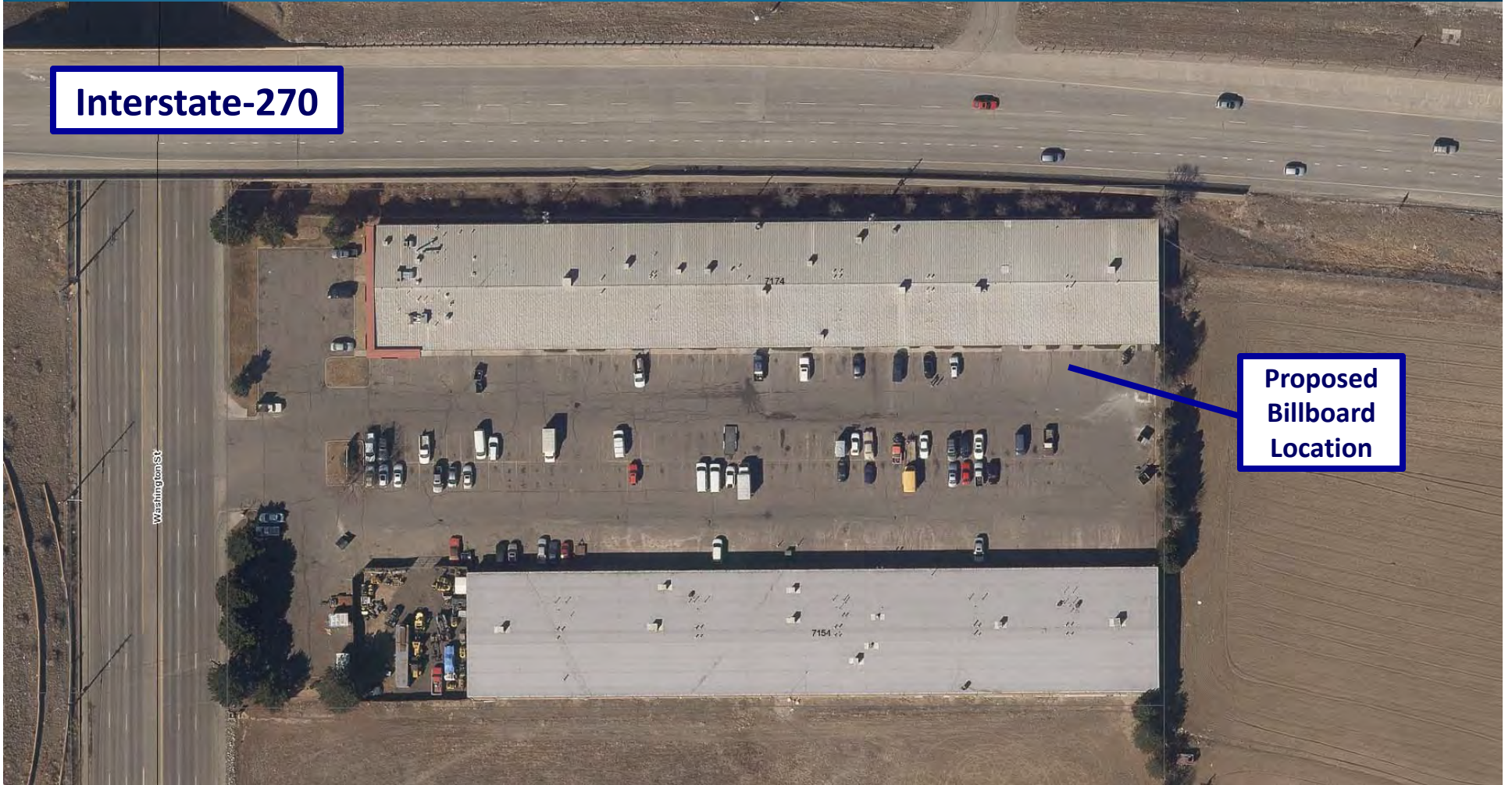

## Current Zoning

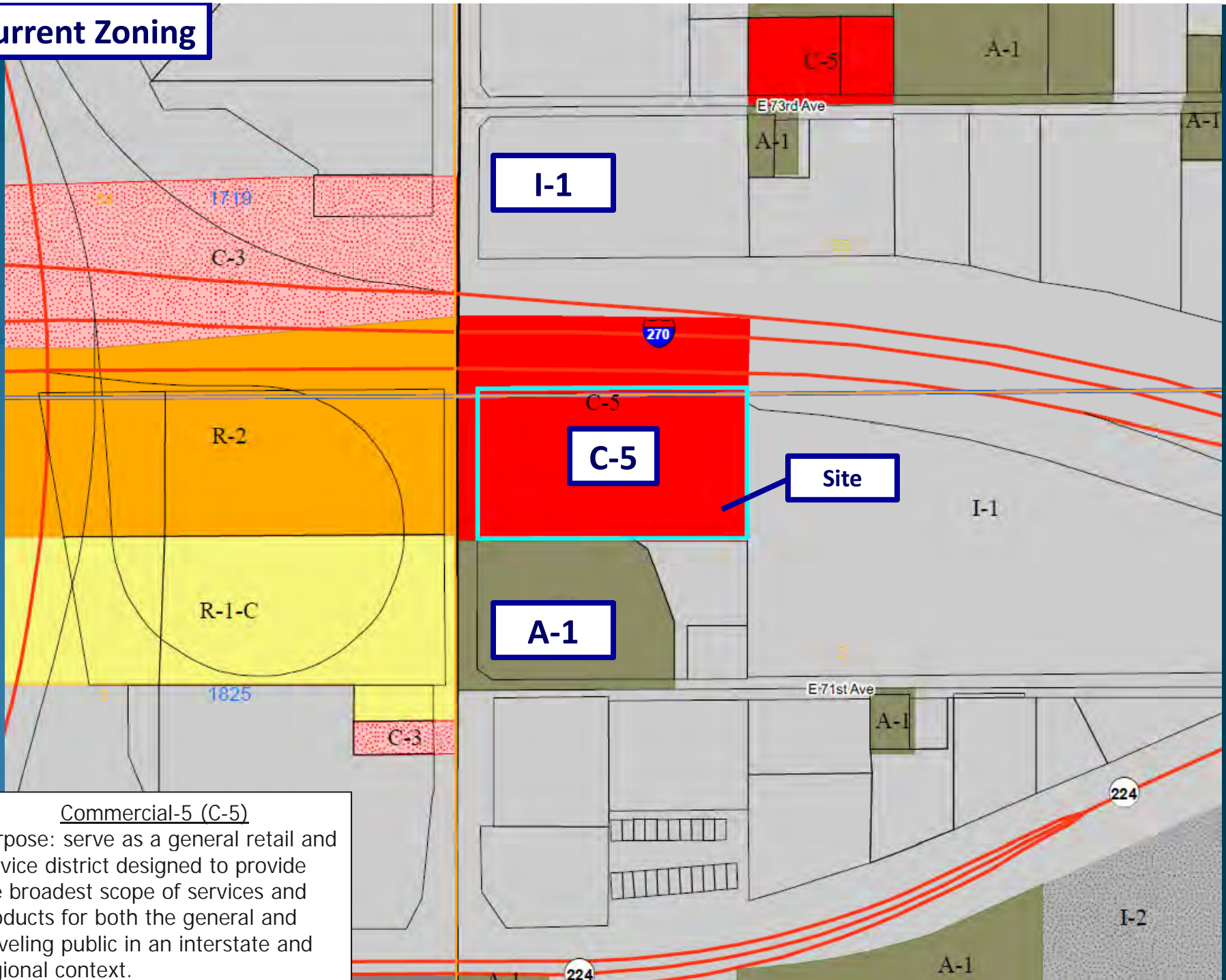

### Commercial-5 (C-5)

Purpose: serve as a general retail and service district designed to provide the broadest scope of services and products for both the general and traveling public in an interstate and regional context.

# Future Land Use Map

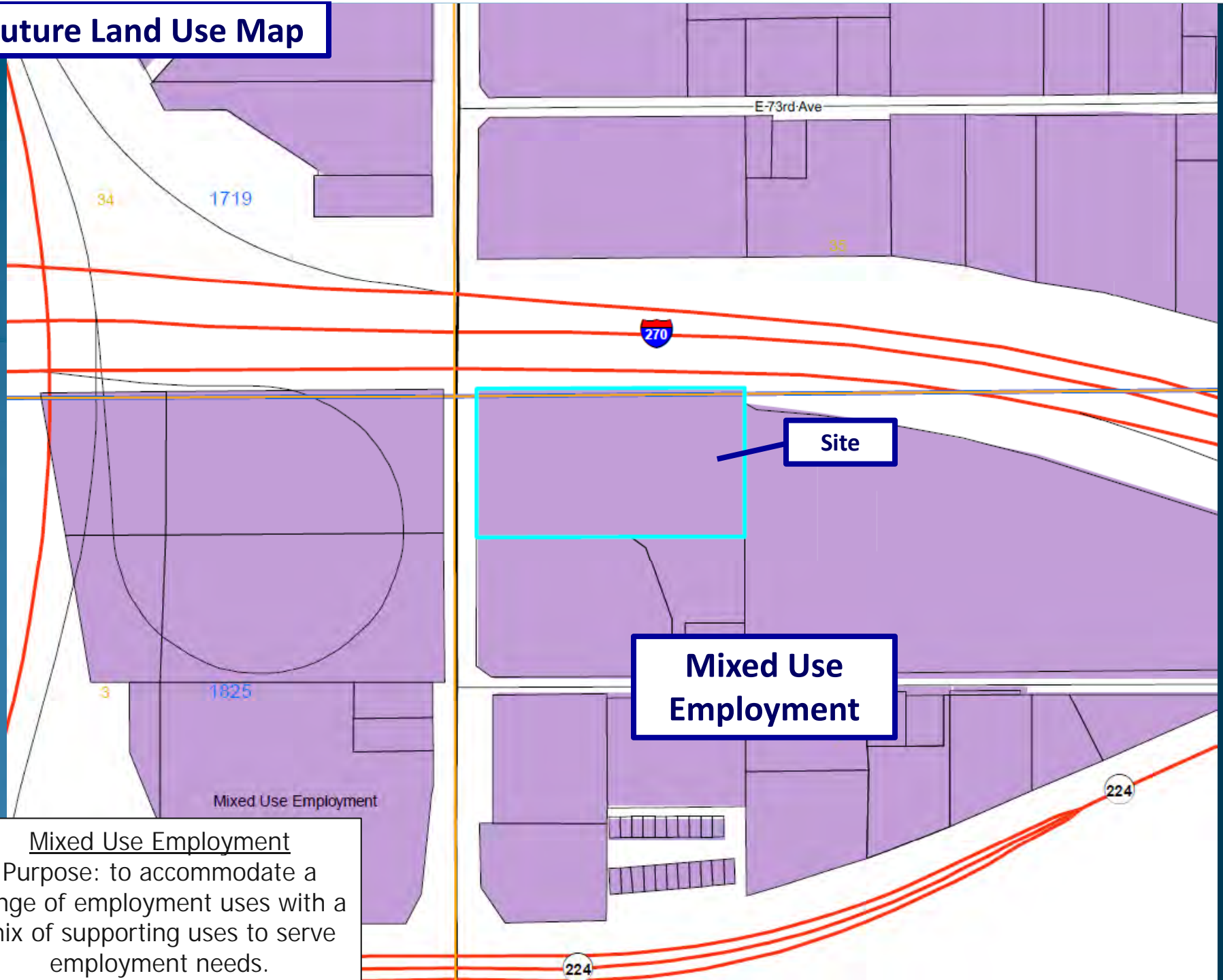

Mixed Use Employment  
Purpose: to accommodate a range of employment uses with a mix of supporting uses to serve employment needs.

# Criteria for Conditional Use

Section 2-02-09-06

1. Permitted in zone district
2. Consistent with regulations
3. Complies with performance standards
4. Harmonious & compatible
5. Addressed all off-site impacts
6. Site suitable for use
7. Site plan adequate for use
8. Adequate services

# Performance Standards

- Maximum Height: 40 feet
- Maximum Size: 300 square feet
- Only one two-faced off-premise sign
- Setback equal to the height
- Minimum 2,000 linear feet spacing between billboards on the same side of the road or interstate
- Sign faces
  - V-Shaped: Maximum of 45 degrees at the interior angle or 15 feet apart at its widest point, whichever is less
- Images must remain motionless for a minimum of 4 seconds with 10 seconds being optimal

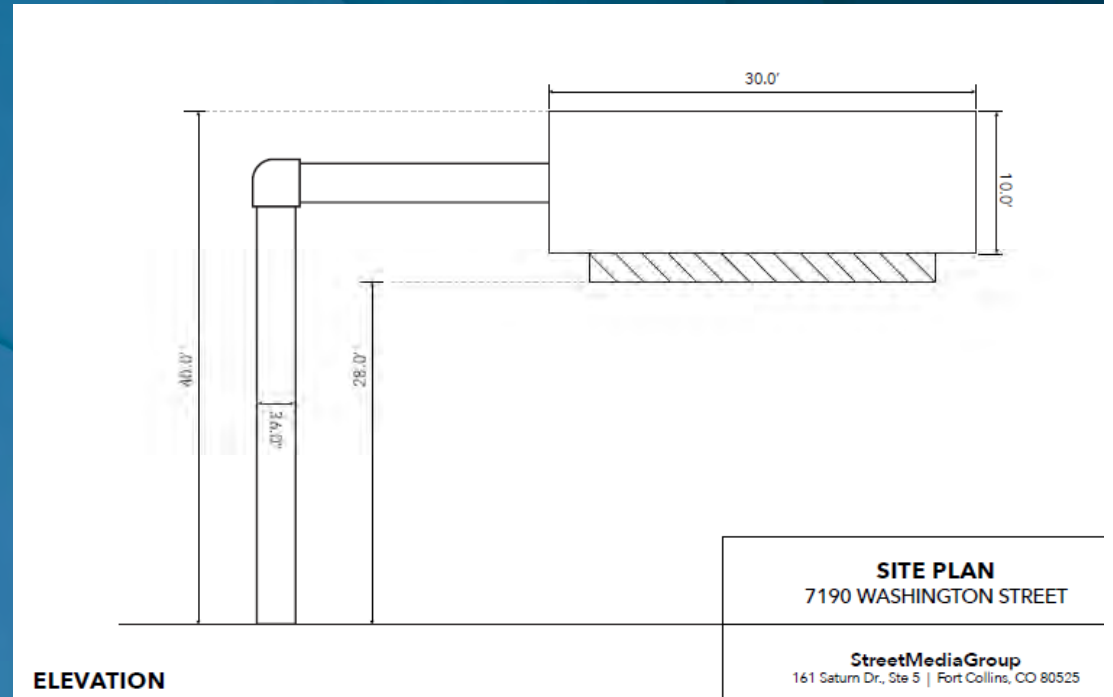

# Applicant Site Plan

I-270

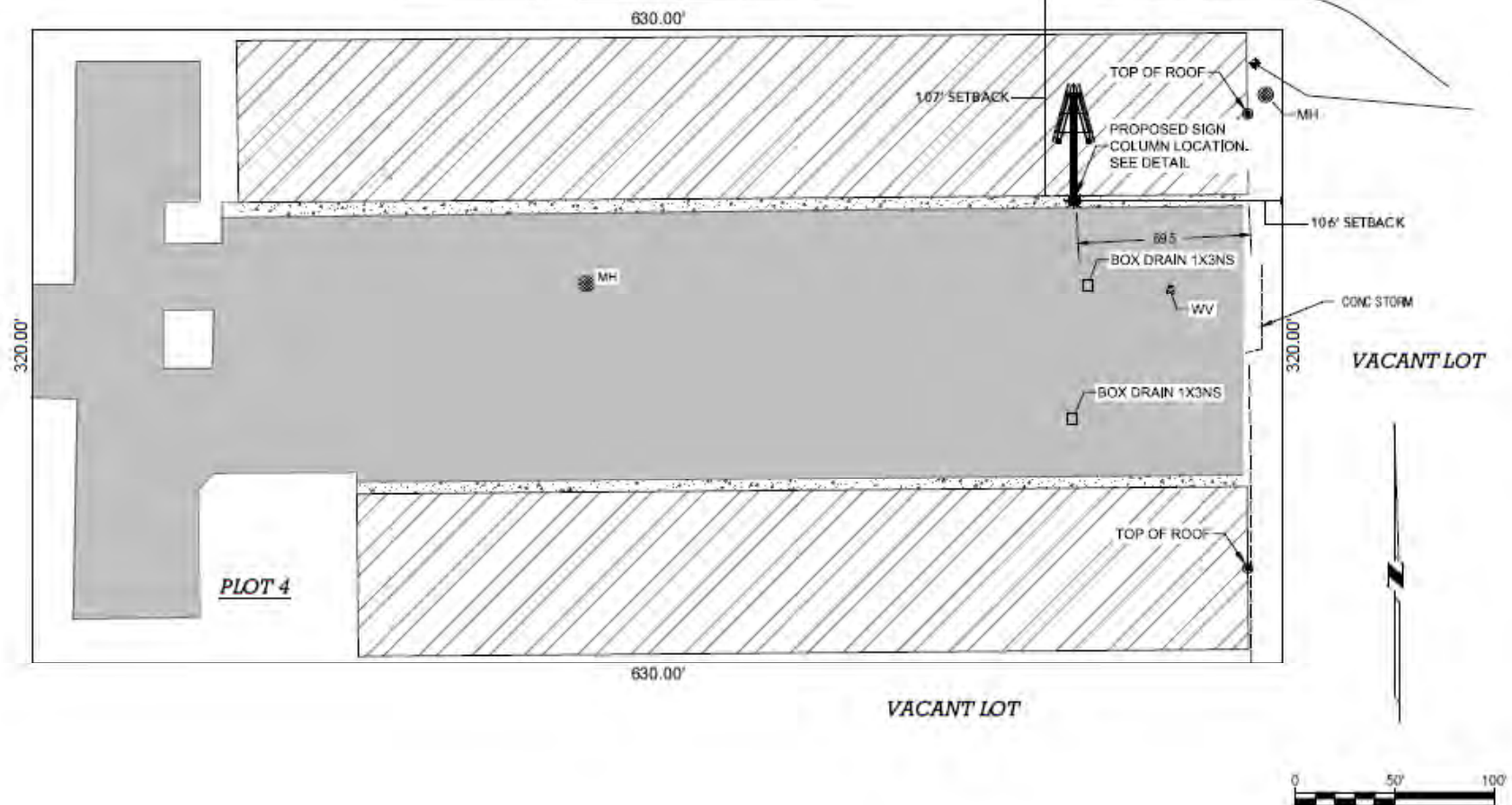



# Applicant Site Plan

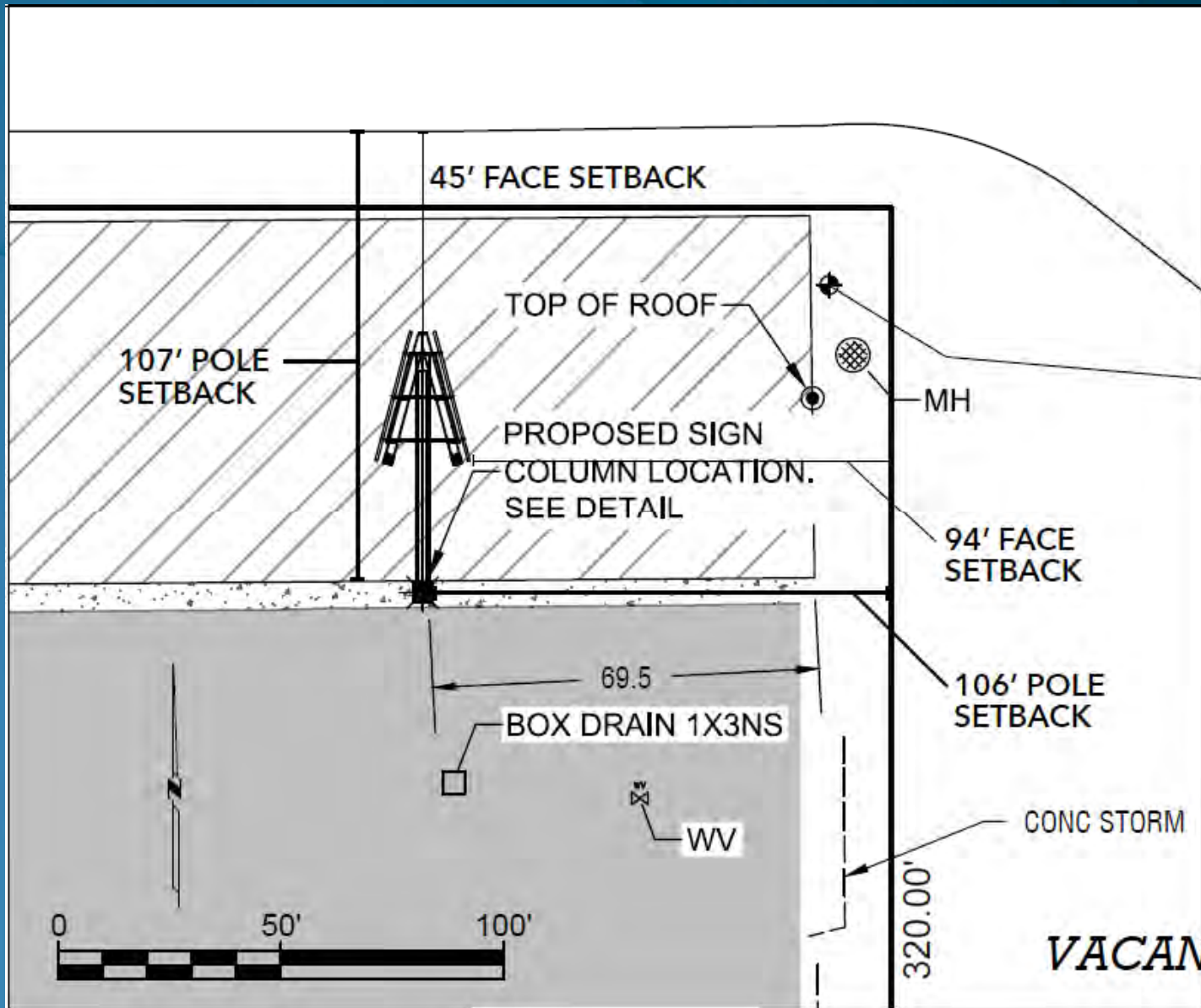

# Applicant Vicinity Map









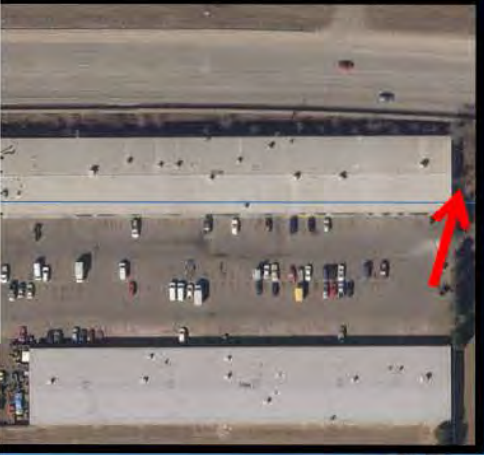

# Applicant Photo with Billboard



PHOTOSIMULATION

# Applicant Photo with Billboard

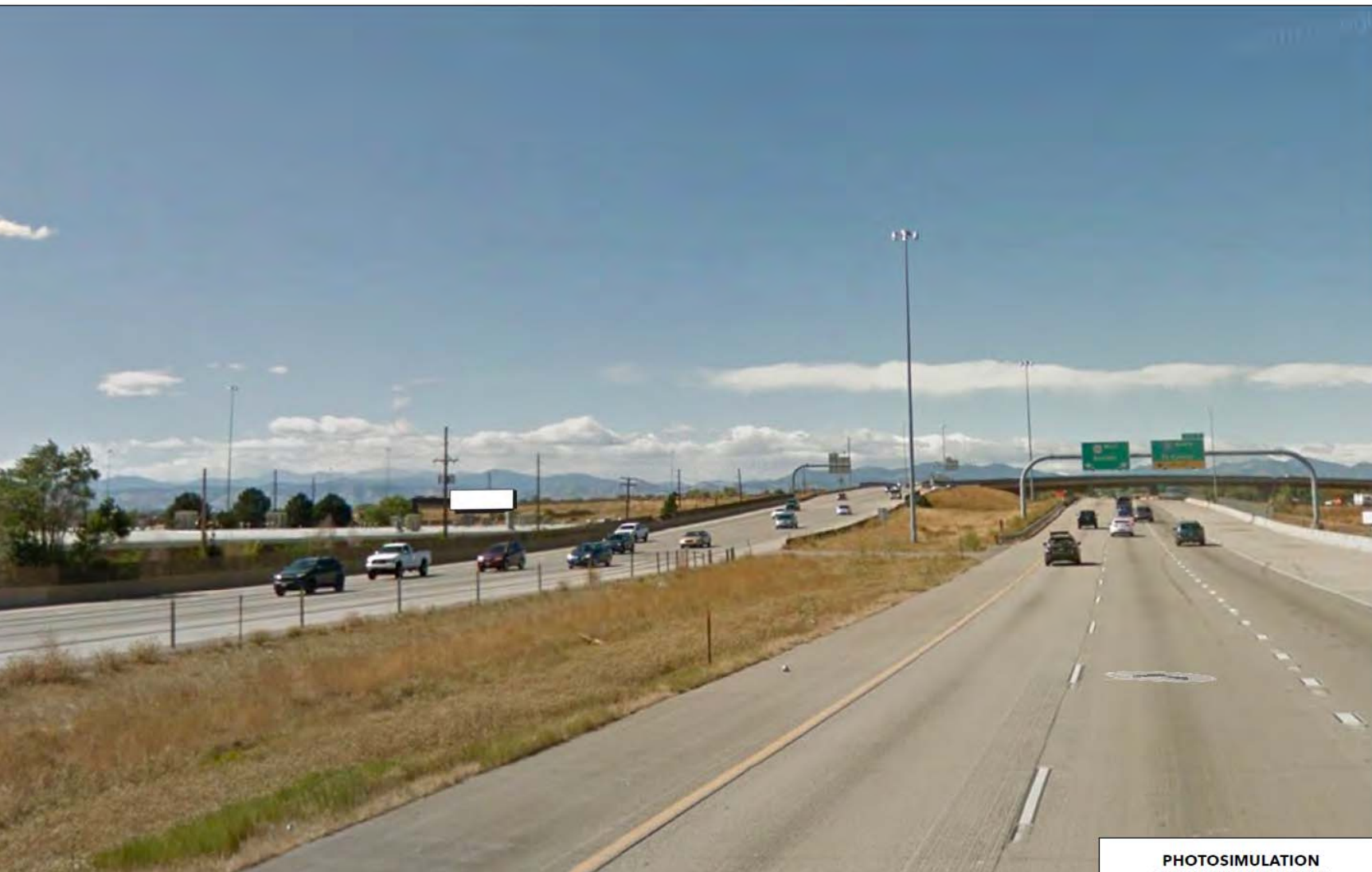



# Referral Comments

Notifications Sent*	# Comments Received
243	0

\*Property owners and occupants within 1,000 ft.

Referral Agencies:

Responding without concern: CDOT, RTD, TCHD, XCEL

No concerns were identified

# Planning Commission Update

(January 28, 2021)

inquired about the minimum 4 seconds that each message must be displayed on the billboard as compared to the optimal 10 seconds that the County's Development Standards and Regulations commends that each message should be displayed on the billboard.

acknowledged that Conditional Use Permit approval for the same use on this site was previously considered and granted through public hearing in 2019.

# PC and Staff Recommendation

(RCU2020-00014 StreetMedia 7154 Washington Billboard CUP)

Staff recommends APPROVAL of the subject request (RCU2020-00014) with 8 Findings-of-Fact, 6 Conditions, and 3 Notes to the applicant.

# Recommended Findings-of-Fact

The conditional use is permitted in the applicable zone district.

The conditional use is consistent with the purposes of these standards and regulations.

The conditional use will comply with the requirements of these standards and regulations, including but not limited to, all applicable performance standards.

The conditional use is compatible with the surrounding area, harmonious with the character of the neighborhood, not detrimental to the immediate area, not detrimental to the future development of the area, and not detrimental to the health, safety, or welfare of the inhabitants of the area and the County.

The conditional use permit has addressed all off-site impacts.

The site is suitable for the proposed conditional use including adequate usable space, adequate access, and absence of environmental constraints.

The site plan for the proposed conditional use will provide the most convenient and functional use of the lot including the parking scheme, traffic circulation, open space, fencing, screening, landscaping, signage, and lighting.

Sewer, water, storm water drainage, fire protection, police protection, and roads are available and adequate to serve the needs of the conditional use as designed

# Recommended Conditions

The applicant must show compliance with all the requirements of the Colorado Outdoor Advertising Act, C.R.S. 43-1-401 et. Seq. and the Colorado rules and regulations promulgated thereunder by the Colorado Department of Transportation.

The applicant shall obtain an Outdoor Advertising Permit from the Colorado Department of Transportation.

The applicant shall obtain a building permit from Adams County for the billboard, including all required building permit inspections.

Each message displayed on the billboard shall remain static for a minimum of four (4) seconds and must transition immediately to the next message displayed.

The leading edge of the billboard sign pole must be placed equal to or greater than the height of the structure from the north property line, in accordance with the County's Development Standards and Regulations. A site plan demonstrating compliance shall be submitted with the building permit application.

The approval of the off-premise sign shall expire February 23, 2031, unless renewed.

# Recommended Note to the Applicant

All applicable building, zoning, health, fire, and engineering requirements and codes shall be adhered to with this request. The applicant may submit an alternative design that can be approved through a Minor Amendment to this Conditional Use Permit by staff, as long as the design complies with the Adams County Development Standards and Regulations at the time of building permit application.

The Conditional Use Permit shall expire on February 23, 2022, if sign permits are not obtained from Adams County.

Any sign or attractive device which includes animated images or graphics, scrolling messages, video, moving images similar to television images, emits audible sounds, employs stereopticon, or includes motion picture projection is prohibited.

# Light Analysis

**Yellow Lines** illustrate how the sign brightness drops rapidly from **80%** to **20%** to **1%** due to the incorporation of **Siteline Blocking Louvers Technology**.

**Yellow** represents calculated illuminance figures at selected locations in **foot-candles[fc]**. A full moon has a light impact of approximately **0.03 fc**. A value less than this is considered **negligible**.

Parameters:

- Display Luminance = 300 NITS

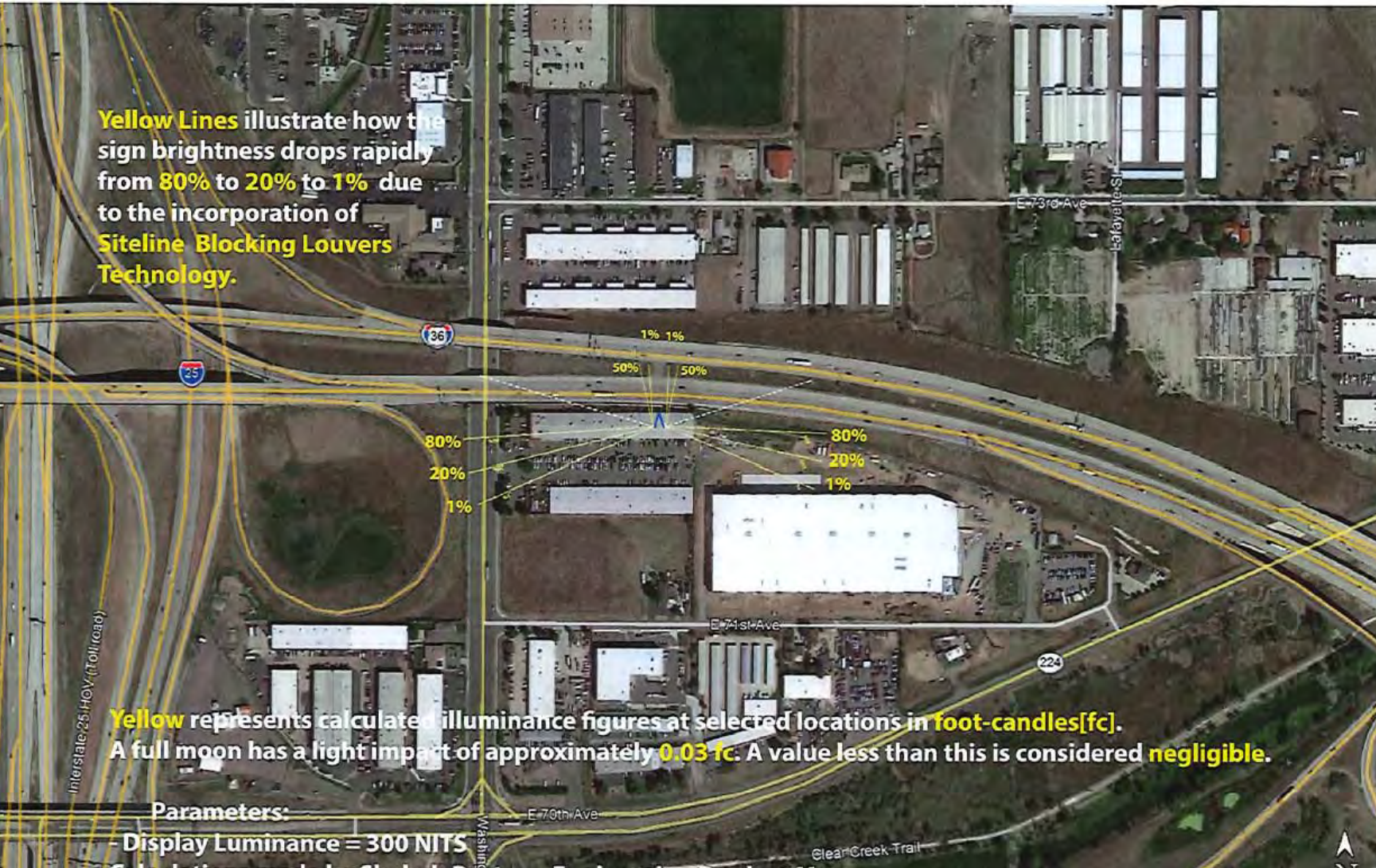

# Southwest Area Framework Plan

Policy 14.7 to Enhance the area's role as an important County Gateway. Strategies in completing the goals include:

- 1) 14.7.a. Entryway Image
- 2) 14.7.b. Screening and Buffering
- 3) 14.7.c Signs- Review and update the sign regulation provisions, including control of off-premise signs, applicable to private lands visible from I-70, I-25, and I-76 and key highway exits into the County.



# Applicant Site Plan

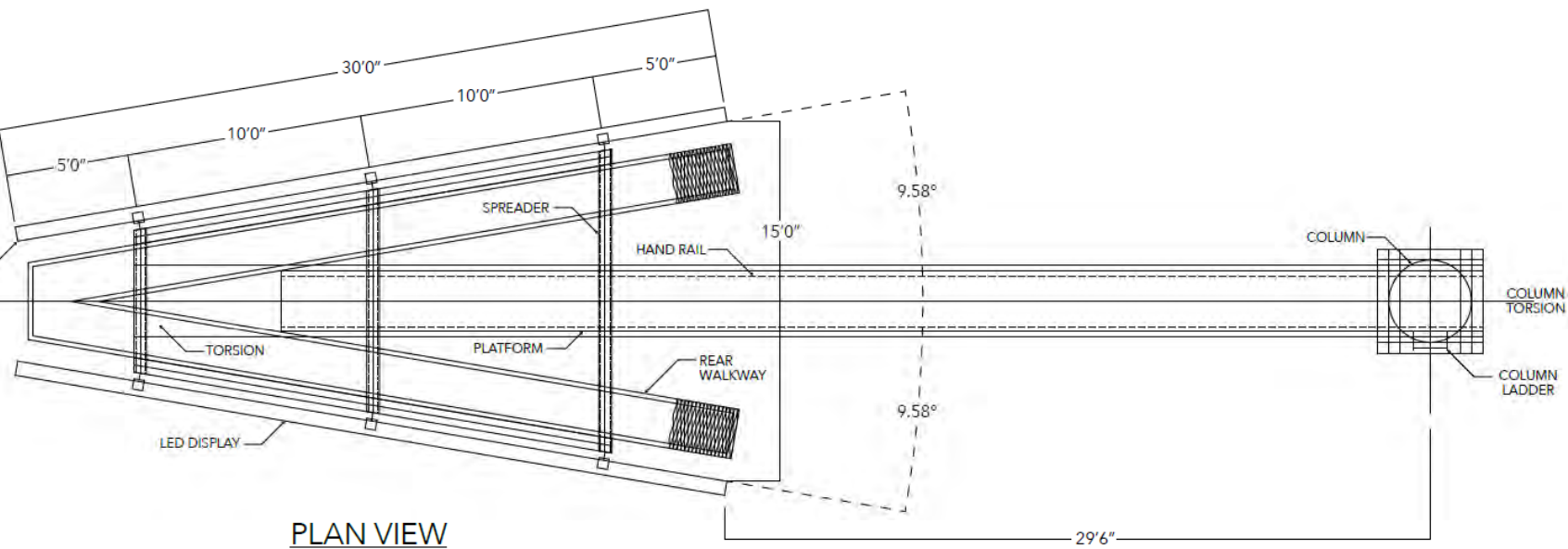

PLAN VIEW